

Created by
[Created by]
Case number
[Case number]

Document date
[Document date]

Confidentiality level
[Confidentiality level]

Section 506 Järna – Åby, East Link Route 36, Götaland Line

Functional description: Ålberga contract

Project number:

Document title: Functional description, Ålberga contract Case number: KOM-418286

Project number:

Created by
[Created by]
Case number
[Case number]

Document date
[Document date]

Confidentiality level
[Confidentiality level]

A. COMMON REQUIREMENTS	5
C. EXISTING LAND, ENVIRONMENT AND STRUCTURES	17
C1. Existing land and environment	17
C1. Existing land and environment / Public water supply	20
C1. Existing land and environment/Private water supply	21
C1. Existing land and environment/ Rock engineering	21
C1. Existing land and environment/ Geotechnics	22
C1. Existing land and environment/Hydrogeology	23
C1. Existing land and environment/Hydrogeology/Larslundsmalmen groundwater body	27
C1. Existing land and environment/Hydrogeology/Vretaån groundwater body	28
C1. Existing land and environment / Agriculture and forestry	29
C1. Existing land and environment/ Cultural environment	32
C1. Existing land and environment/ Cultural environment// Protection of ancient monuments and other remains outside the work area	32
C1. Existing land and environment/Cultural environment//Vibrations and buildings of cultural value	33
C1. Existing land and environment/ Cultural environment// Roads of cultural value	34
C1. Existing land and environment/ Landscape and built-up areas	34
C1. Existing land and environment/ Land and water pollution	36
C1. Existing land and environment/ Land drainage works, ditches, etc.	38
C1. Existing land and environment/ Surveying data	50
C1. Existing land and environment / Natural environment	50
C1. Existing land and environment/ Recreation and outdoor activities	52
C1. Existing land and environment/ Vibration, air shock, noise	53
C1. Existing land and environment/ Surface water	54
C1. Existing land and environment/Surface water/N2000 area Kilaån-Vretaån with tributaries	59
C1. Existing land and environment/Surface water/Lake Stavsjön	63
C2. Existing structure/Building	64
C2. Existing structure/Drainage system	64
C2. Existing structure/ Boundary marking	64
C2. Existing structure/Railway infrastructure	64
C2. Existing structure/ Core network	65
C2. Existing structure/Cables	65
C2. Existing structure/water and sewerage network	66
C2. Existing structure/ Road infrastructure	66
C2. Existing structure/ Roads	67
D. ROAD	69
D. Road// Group 1	74

Created by
[Created by]
Case number
[Case number]

Document date
[Document date]

Confidentiality level
[Confidentiality level]

D. Road// Group 1/ Temporary road	75
D. Road// Group 3	76
D. Road// Group 4	76
D. Road// Group 4/ Technical estates	78
DB. Road construction	78
DB11b. Road surface	79
DB12c. Unbound base course	85
DC. Road safety device	95
DD. Road signs, road markings and roadside markings	101
<i>F. RAILWAY</i>	107
FB. Bank construction	108
FC. Signalling systems	141
FD. Railway Power Supply	142
FE. Electrical systems	142
FF. Telecommunications systems	142
FG. Facility monitoring systems	142
FJ. Cable ducting system	142
FK. Technical building, curve, cabinet, etc.	143
<i>G. BRIDGE STRUCTURE</i>	144
G. Bridge construction/ Road bridge	144
G. Bridge design/ Railway bridge	145
GJ. Crossing structure	147
GK. Drainage system	148
<i>V. EXTERNAL STRUCTURE</i>	149
V. External works/ Existing pipes and fittings	149
<i>X. DOCUMENTATION</i>	149
X. Documentation/Digital project management	149
X. Documentation/Approval process	151
XB. Design Specification	151
XB. Design Specification/ Bridges and bridge-like structures	152
XC. Construction documents	152
XC. Construction documents/ Drainage/Water and sewerage	153
XC. Construction documents/Rock engineering	154
XC. Construction documentation/ Bridges and bridge-like structures	155
XC. Construction Documents/Geodetic Surveying	155
XC. Construction Drawings / Geotechnics	155
XC. Construction documentation/Hydrogeology	156
XC. Construction documentation/Component ID, road	157

Created by
[Created by]
Case number
[Case number]

Document date
[Document date]

Confidentiality level
[Confidentiality level]

XC. Construction documentation/ Landscape and design	157
XC. Construction documentation/Utility coordination	157
XC. Construction Documents/Land	158
XC. Construction documentation/ Waste management plan	158
XC. Construction documents/Environment	158
XC. Construction documents/Road construction	159
XC. Construction documents/Road design	159
XD. Final documentation	159
XD1. BIM – Building Information Model	159
XD2. Basis for the relationship document	159
XD2. Relationship document	160
XD2. Relationship document / Railway facility	160
XD2. Route documentation/ Road infrastructure	160
XD2. Design documentation/ Drainage/Water and sewerage	161
XD2. Design documentation/ Rock	161
XD2. Relational drawing/ Bridge and bridge-like structures	162
XD2. Geodetic Surveying/Geodetic Surveying Techniques	162
XD2. Survey Documentation/Geotechnical Engineering	162
XD2. Report/Hydrogeology	162
XD2. Relationship document/ Landscape and design	163
XD2. Relationship document/ Environment	163
XD3. Management data/environment	164
XD3. Management data/Railway	164
XD3. Management data/Railway/Power supply facility	164
XD3. Management data/ Road	164
XD3. Management data/ Component ID, road	165
XD3. Management data/ Environment	165
XD4. Operation and maintenance plan	165
XD4. Operation and maintenance plan/ Drainage	166
XD4. Operation and maintenance plan/ Bridges and bridge-like structures	166
XD4. Operation and maintenance plan/ Landscape and design	166
XD4. Operation and Maintenance Plan / Environment	166
<i>List of referenced requirements documents.</i>	<i>168</i>
List A. Common requirements, X. Documentation and common requirements documents (D and F).	169
List D. Road	173
List DH. Traffic management and facility monitoring systems	176
List F. Railways	179
List A. Common requirements, X. Documentation and common requirements documents (D and F). The list has not been	



Created by
[Created by]
Case number
[Case number]

Document date
[Document date]

Confidentiality level
[Confidentiality level]

finalised _____	197
List D. Road The list has not been finalised _____	199
List F. Rail (Items marked in yellow are not included in Chapter F _____	201

A. COMMON REQUIREMENTS

General

Although the railway plan, design and specified requirements constrain parts of the design, there is scope to work together to find smart and cost-effective solutions. The contractor and the client shall, through collaboration, identify and develop solutions that contribute to increased efficiency and add value to the project.

The investigation and design work, as well as the construction, must be carried out efficiently and focused on identifying solutions and designs that meet the project objectives and the site-specific requirements set for the project in the most optimal way possible. Progress towards objectives, impacts and consequences must be monitored on an ongoing basis.

Scope

Refers to all sections of the Functional Specification (FS) except “V. External Construction”.

Created by
[Created by]
Case number
[Case number]

Document date
[Document date]

Confidentiality level
[Confidentiality level]

Scope/General description

The “Ålberga” contract comprises the design and construction of approximately 28 kilometres of double-track railway, as well as associated facilities in accordance with this description.

The project covers the section km 63+300 – 91+275, which refers to OLP3’s longitudinal measurement. Km 63+300–km 69+400 comprises Railway Plan 32 (Sjösa–Skavsta), km 69+400–km 91+275 comprises Railway Plan 33 (Skavsta–Stavsjö). OLP3 comprises all railway plans within the municipality of Nyköping; Sillekrok–Sjösa, Sjösa–Skavsta, Skavsta–Stavsjö, Nyköping Bibana and Nyköping Resecentrum.

Within the contract, there is a junction at km 72+970, at which point the distance measurement changes to km 73+000.

As a basis for land claims, standard cross-sections in Appendix X have been produced during the system design phase. The standard cross-section shall be used as the basis for establishing a standard profile in accordance with current requirements.

Scope/Land access

The designated railway area and work area are shown in plan drawings OLP3-01-111-32-0_0, sheets 1800–2300, and OLP3-01-111-33-0_0, sheets 0100–2300.

Areas with “Temporary right of use” (T-areas) are shown in plan drawings OLP3-01-111-32-0_0, sheets 1800–2300, and OLP3-01-111-33-0_0, sheets 0100–2300.

Unless otherwise specified, areas with temporary right of use must be restored to their previous condition following the final inspection, and the areas must be usable in the same way as before the works.

Once the railway plan and the property formation decision from the Land Survey Authority have become legally binding, the contractor shall have access to all areas with ownership rights and easement rights within the work area.

Once the railway plan has come into force, the client shall ensure that areas with right of way, restricted right of way and temporary right of use are utilised.

Areas where only Js1, Js8 or Js12 are indicated may not be used.

Areas for private roads are shown on illustrative maps; see **Figure (A).2 below**.

Access to areas designated for private roads may be granted at the earliest after a construction decision has been made in a land survey procedure. The contractor must therefore check with the Swedish Transport Administration regarding access to private roads at the start of the project.

Figure (A) 2, Private road not specified in the railway plan:

Illustrative map	Length measurement	Property	Purpose	Reference
OLP3-01-114-32-0_0-1800	64+000	Listorp	Replacement road	Table D. ROAD Group 3
OLP3-01-114-32-0_0-2100	67+450-69+000	No data available	Alternative route	Table D. ROAD Group 3
OLP3-01-114-32-0_0-2100	69+050	No data	Replacement route	Table D.ROAD Group 3

Created by
[Created by]
Case number
[Case number]

Document date
[Document date]

Confidentiality level
[Confidentiality level]

OLP3-01-114-33-0_0-0400	72+250	Hälla Hälladal	Replacement road	Table D.ROAD Group 3
OLP3-01-114-33-0_0-0500	73+920	Information missing	Replacement route	Table D.ROAD Group 3
OLP3-01-114-33-0_0-0700	75+650	No data available	Compensation route	Table D. ROAD Group 3
OLP3-01-114-33-0_0-0800	78+160	No data	Replacement route	Table D.ROAD Group 3
OLP3-01-114-33-0_0-1400	82+820	No data	Replacement route	Table D.ROAD Group 3
OLP3-01-114-33-0_0-1400	82+940	No data	Replacement route	Table D.ROAD Group 3
OLP3-01-114-33-0_0-1600	84+210	Eriksgatan	Alternative route	Table D.ROAD Group 3
OLP3-01-114-33-0_0-1800	86+200	No data available	Replacement route	Table D.ROAD Group 3
OLP3-01-114-33-0_0-1900	87+650	Nunnebanan	Replacement road	Table D.ROAD Group 3
OLP3-01-114-33-0_0-2000	88+890	Information missing	Replacement route	Table D.ROAD Group 3
OLP3-01-114-33-0_0-2100	89+730 - 90+200 N	No data available	Alternative route	Table D. ROAD Group 3
OLP3-01-114-33-0_0-2100	89+730 - 90+200 S	No data available	Alternative route	Table D. ROAD Group 3
OLP3-01-114-33-0_0-2100	89+690	Kila Solvik East	Replacement road	Table D.ROAD Group 3
OLP3-01-114-33-0_0-2200	91+120	Information missing	Replacement route	Table D.ROAD Group 3
OLP3-01-114-33-0_0-2201	91+340	No data	Replacement route	Table D.ROAD Group 3

Scope/Physical barrier

The entire new railway line is to have a physical barrier on both sides, as shown in the plan drawings OLP3-01-111-32-0_0, sheets 1800–2300, and OLP3-01-111-33-0_0, sheets 0100–2300. The physical barrier consists of fencing and a noise barrier adjacent to the railway.

Scope/Materials Management

Created by
[Created by]
Case number
[Case number]

Document date
[Document date]

Confidentiality level
[Confidentiality level]

For earthworks, including the handling of surplus earth, the Ostlänken overall earthworks management plan "Pm Overall Earthworks Management Plan TRV2022/125611" must be followed.

The contractor shall be responsible for obtaining the necessary permits to use the materials employed in the works.

The contamination situation is specified under code C1. Existing ground and environment/Soil and water contamination, C2. Existing structure/Road construction and C1. Existing ground and environment/Rock engineering.

The basis for the description of the scope is provided in the earthworks analyses from the system design phase for the section between Sjösa and Skavsta and the section between Skavsta and Stavsjö (to be provided after the contract is signed).

Approximate quantities:

Earthworks: 720000 m³

Rock excavation: 1150,000 m³

Scope/Technical yard

The following information is shown in the service yard drawings OL00-60-110-00000-0_0, sheets 0001–0019:

- Type and design of the plant yards
- Dimensions of the technical buildings
- Dimensions of the ground area for the Radio Tower
- The location of the technical buildings and the Radio Tower relative to the

centre of the track Technical yards are to be constructed at the following locations:

- Service yard, Km 64+032; U-track Type D1
- Equipment yard, Km 66+150; N track Type D1
- Technical yard, Km 67+975; N track Type D1
- Technical yard, Km 68+650; N track Type B
- Technical yard, Km 69+900; N track Type D1
- Maintenance depot, Km 70+354; U-track No maintenance depot type – Detector kiosk
- Technical yard, Km 71+155; N track Type A
- Equipment bay, Km 71+159; N track Type A
- Equipment bay, Km 71+785; U-track Type D1
- Equipment bay, Km 72+698; N track Type A
- Equipment yard, Km 72+702; N track Type A
- Technical yard, Km 73+945; U-track Type D1
- Technical yard, Km 74+355; N-track Type A
- Technical yard, Km 74+359; N-track Type A
- Technical yard, Km 76+125; U-track Type D1
- Technical yard, Km 77+512; N-track Type A
- Technical yard, Km 77+516; N track Type A

Created by
[Created by]
Case number
[Case number]

Document date
[Document date]

Confidentiality level
[Confidentiality level]

- Technical yard, Km 77+944; U-track Type D1+E
- Maintenance yard, km 79+210; N-track Type A
- Maintenance depot, km 79+214; N track Type A
- Maintenance yard, Km 79+890; N track Type D1
- Maintenance yard, km 80+806; N track Type A
- Maintenance depot, km 80+811; N track Type A
- Technical yard, Km 82+080; N track Type D1
- Technical yard, Km 82+314; N track Type A
- Technical yard, Km 82+318; N track Type A
- Equipment yard, Km 84+050; U-track Type D1
- Equipment yard, Km 85+478; N track Type A
- Technical yard, Km 85+482; N track Type A
- Technical yard, Km 86+144; N track Type D1+E
- Equipment yard, Km 87+102; N-track Type A
- Technical yard, km 87+106; N track Type A
- Maintenance yard, Km 88+020; N track Type D1
- Maintenance yard, km 88+871; U-track Type A
- Maintenance depot, Km 88+875; U-track Type A
- Technical yard, Km 90+150; N track Type D1
- Technical yard, Km 90+403; N track Type A
- Technical yard, Km 90+407; N-track Type A

Scope/Design

The facility shall be designed with a cohesive design within the project and the East Link as a whole. It shall be well adapted to and integrated with the surrounding landscape and built environment.

The design and execution must take into account the natural and cultural environment as well as other environmental aspects.

The design of all parts of the Ostlänken facility and ground connections is assigned design classes (Class 1–Class 3). The classification is based on previous assessments and evaluations made in the detailed landscape analysis of the landscape's sensitivity and the railway facility's impact from the perspective of observers and passengers. Each design class is assigned a requirement level; see Figure (A).3 below.

Design Class 1 The visual and experiential aspects are not particularly sensitive to change. An area that, without special measures, can accommodate the new railway and which has little impact on the landscape.	Requirement level: Basic	Priority level: Basic
Design class 2	Requirement level: Medium	Priority level: Medium

Created by
 [Created by]
Case number
 [Case number]

Document date
 [Document date]

Confidentiality level
 [Confidentiality level]

The visual and experiential aspects are moderately sensitive to change. A valuable landscape where consideration must be given when siting the railway facility.		
Design class 3	Requirement level: High	Priority level: High
The visual and experiential aspects are highly sensitive to change. A landscape of great value or a highly exposed site where great care must be taken when siting the railway facility.		

Figure (A).3. Description of design classes with associated requirements.

Four areas of high design value are included in this FB. These are the areas assessed as having high landscape value, being highly exposed or set to be used extensively.

The infrastructure elements in the focus areas have design class 2 or 3 and a high level of architectural ambition. The treatment of other infrastructure elements is described and requirements are set out in accordance with the identified design class under the respective coded heading.

Focus areas within the section:

1. Hälladal
2. Ålbergaån
3. Vretaån
4. Rosenberg

In addition to these areas, which are highlighted in the Design Programme for Skavsta–Stavsjö, there is the area along Road 52, which includes a planned landscape bridge over the same road. The landscape is not sensitive to change, but the landscape bridge will be highly visible, which is why Design Class 3 should also be applied here. Aspedal and Eriksgatan are not focus areas, but due to their visibility within the landscape, these locations require particular care in the design of bridges.

Scope/Permits

The Swedish Transport Administration is responsible for preparing the application for a water activities permit. The water activities permit stipulates that the water activities must be carried out in accordance with the provisions set out in the application, the accompanying technical description and other documents, as well as the commitments undertaken by the Swedish Transport Administration.

Scope/Hydrogeology

Where the groundwater level is lowered during the construction period using drainage pipes/drainage wells or similar, these must be sealed to prevent continued drainage of groundwater during restoration.

Scope/ Remaining investigation work

Created by
[Created by]
Case number
[Case number]

Document date
[Document date]

Confidentiality level
[Confidentiality level]

Certain investigation and inventory work remains to be carried out in order to assess the need for protective measures in areas such as nature and cultural conservation, as well as regarding the control or containment of invasive species. These investigations and inventories will be carried out by the client as preparatory work. It is the contractor's responsibility to implement measures in accordance with the findings of these investigations and inventories. The measures may include the provision of physical protection for nature and cultural heritage sites adjacent to the work area and access routes, measures to enhance biodiversity within the tree protection zone, and measures to control or limit the spread of invasive species.

Function

The requirements of the following regulations must be met:

- TRVINFRA-00226 "Bridges and bridge-like structures, General requirements".
- TRVINFRA-00227 "Bridges and bridge-like structures, Construction".
- TRVINFRA-00228 "Bridges and bridge-like structures, Bridge maintenance".
- TRVINFRA-00229 "Geotechnical Engineering, Administrative Rules".
- TRVINFRA-00230 "Geotechnical Structures, Design and Layout".
- TRVINFRA-00231 "Drainage, Design and Layout".
- TDOK 2022:0063 "Environmental classification and assessment of soil masses, Requirements".
- TDOK 2022:0064 "Environmental classification and assessment of soil masses, Guidance".
- TDOK 2010:311 "Chemical products – review criteria and requirements for the Swedish Transport Administration".
- TDOK 2010:310 "Chemical products – review of chemical products subject to labelling requirements".
- TDOK 2014:0911 "Roadside ditch spoil – sampling and handling REQUIREMENTS".
- TDOK 2015:0491 "Roadside ditch spoil – sampling and handling GUIDELINES".
- OLP0-08-025-0000-0020 "Investigation Memorandum, Design assumptions, climate resilience, 15 June 2023".
- OLP0-08-025-4000-0_0-0021 "Investigation Memorandum, Design Conditions, Climate Resilience, 25 March 2019".
- OLP0-08-025-4000-0_0-0022 "Investigation Memorandum, Basis for Design Conditions, Climate-proofing, 25 March 2019".

If the technical solution chosen by the contractor does not refer to the aforementioned publications concerning requirements for the Swedish Transport Administration's facilities, for road operational environments, a specific specification of requirements regarding inspection shall be drawn up in accordance with:

- Requirements for Road Superstructure, Dimensioning and Design, Chapter 5.6.2.2
- Requirements for Geotechnical Engineering, Administrative Rules, Chapter 5.4
- Requirements for Drainage, Design and Layout, Chapter 5.2

Created by
[Created by]
Case number
[Case number]

Document date
[Document date]

Confidentiality level
[Confidentiality level]

Unless otherwise specified, the works shall be carried out in such a way that existing land and the environment outside the work area are not adversely affected and functions are not impaired during execution, after completion or during future operation and maintenance.

The design and construction of the facility, including operation and maintenance, shall take into account the impact on energy consumption and climate impact from a life-cycle perspective.

The facility shall be designed and constructed so that operation, maintenance and fault rectification can be carried out cost-effectively and in a manner that complies with health and safety standards, using established methods.

There must be technical uniformity within the facility. Technical uniformity aims, among other things, to minimise the need for spare parts, expertise, maintenance methods and machinery. This leads, among other things, to more efficient and cost-optimised maintenance. The plant shall be constructed and designed in such a way as to ensure a high level of safety for future maintenance work and a high level of safety within the plant. The facility shall be designed so that operationally critical parts of the facility are easily accessible during maintenance. The intention is to improve the facility's maintainability to enable trains to run on time and to reduce the time required for maintenance (and thus downtime) during, for example, dismantling, troubleshooting, fault isolation, inspection and repairs.

Flammable materials as defined in MSBFS 2010:4 must not be present within the facility's area once the facility is complete.

The facility must be protected against and resistant to graffiti.

The facility must be designed and constructed in such a way as to minimise sabotage, vandalism and theft of equipment.

Ongoing water checks of the facility (e.g. water levels, amount of water ingress, sampling, etc.) during the operational phase must be able to be carried out without hindering traffic or compromising the safety of the person taking the samples.

Function/Design

The Ostlänken project is designed with a holistic perspective – the finished facility is designed with a cohesive layout and with care for both the landscape and the character of individual locations, also taking into account the 'traveller's perspective'. In this regard, the facility is designed so that all constituent parts and the spaces between them are well adapted to and integrated into the surrounding landscape and built environment.

The railway facility shall be designed in accordance with the railway plan, the attached track geometry and other attached documents (sketches, construction drawings, etc.).

The design programmes describe the proposed design based on the project documentation. Further design work may affect the proposed design. However, the choice of construction method must allow for the main features of the required design.

Function/Earthing

The contract includes the design of earthing for plant components and connection points where BEST design is to connect to the S-rail. Including connection to the S-rail

Created by
[Created by]
Case number
[Case number]

Document date
[Document date]

Confidentiality level
[Confidentiality level]

The design and execution of earthing and shielding of the Swedish Transport Administration's railway installations, as well as station areas and road installations in the vicinity of the railway, shall be carried out in accordance with TDOK 2014:0416 "BVS 510, Earthing and Shielding in the Swedish Transport Administration's Installations".

Function/Drainage water

Management of drainage water shall be carried out in such a way that it does not cause any adverse impact on the receiving water body. Discharge of pollutants shall primarily be limited at source. Where flow equalisation is required prior to discharge into the receiving water body, the equalisation shall be carried out to a flow rate corresponding to natural land runoff.

Drainage water shall be managed and treated in accordance with the Contractor's drainage control programme and site-specific work plans. Facilities for the management of drainage water must function regardless of the season, and contingency measures must be in place to be implemented should the facilities fail. The contingency measures must prevent contaminated drainage water from being discharged from the project area.

See also C1. Existing land and environment/Surface water.

Function/Material Handling

Excavated material must not be deposited in such a way as to damage existing facilities. Excavated material must be deposited in a protected manner to prevent direct runoff into nearby lakes and watercourses, using protective measures adapted to the sensitivity of the receiving water body. Storage areas for potentially contaminated spoil must be designed and located in such a way as to minimise the spread of contamination to the surrounding environment.

Function/Material Management/Excavated Material

Ground vegetation and topsoil (excavated material) must be retained for the revegetation of the completed facility and for the restoration of areas with temporary rights of use. The handling and storage of excavated material must be carried out correctly so that micro-organisms, seeds and root fragments are kept alive.

Function/Invasive species

The works must not result in the spread of invasive species within or outside the work area.

Function/ Temporary geostructures

Temporary geostructures shall be designed and constructed to minimise the impact on the surrounding environment and to ensure a safe working environment. Before temporary support structures are left in place, the risk of damming and lowering of the groundwater level shall be investigated, and where necessary, the required measures to counteract the impact on groundwater levels shall be taken.

Function/Tree protection

The track must be cleared of trees to create a maintenance corridor of at least 25 m extending from the centre of the nearest track. Measures within the tree clearance zone must be carried out to achieve a smooth transition to the surrounding forest.

Function/Construction of side areas

Ground surfaces within side areas, i.e. road and railway embankments, ballast beds, etc., shall be vegetated.

Created by
[Created by]
Case number
[Case number]

Document date
[Document date]

Confidentiality level
[Confidentiality level]

The excavated material shall be stored until the side areas have been completed, and then applied as a surface layer. Side areas, such as embankments, ditches, bridge abutments, ballast beds, cuttings and other structural elements along the railway line shall be covered with excavated material, at least 0.1 m thick, if this is the most economically advantageous solution.

Where the clay and nutrient content is high, the excavated material shall be mixed primarily with lean excavated material, and secondarily with lean soil, to reduce vegetative growth and maintenance requirements. The planned approach and choice of material shall be agreed with the client. Topsoil from arable land generally contains a smaller amount of seed and should be reseeded with a grass and meadow seed mixture.

All seed mixtures must be of Swedish origin and adapted to the site's habitat type and conditions, as well as being low-growing and hardy. They must be able to establish themselves quickly and have a deep root system that binds the soil and thus prevents erosion. Seed mixtures must be species-rich and contain herbaceous and grass species found on the site, as specified on the basis of species inventories.

Function/Chemical grouting

Chemical grouting agents may only be used with the client's approval. Approval is based on technical, economic, environmental and occupational health and safety requirements.

Technical solution/Geodetic surveying

See OTB-mät, TLS4110-20GD-052-30-0_0-0001.

Inspection

The contractor shall design and carry out inspections in such a manner and to such an extent that it can be verified that the specified requirements are met.

Inspection methods described in AMA and in standards referenced by AMA shall be applied.

The contractor shall draw up an inspection programme with associated inspection plans for design and execution, as well as for materials and goods used.

The inspection programme shall also include inspection of existing ground, the environment and the structure. Where inspection requirements are specified, these shall be incorporated into the inspection programme and associated inspection plans. If inspection requirements are not specified, the contractor shall specify the inspection method based on the client's requirements or the contractor's chosen technical solution.

The inspection programme and associated inspection plans shall incorporate:

- inspection in accordance with the Swedish Transport Administration's requirements document for the construction of road or railway infrastructure. This shall be carried out if the client's requirements or the contractor's chosen design and execution refer to these.
- inspection in accordance with AMA, with amendments and additions where applicable, in accordance with "TRV AMA Anläggning", category A, bridge or tunnel. This shall be carried out if the client's requirements or the contractor's chosen technical solution refer to AMA.

For a product subject to a requirement for a declaration of performance in accordance with the Construction Products Regulation (CPR), the essential characteristics shall be declared in accordance with the relevant harmonised technical

Created by
[Created by]
Case number
[Case number]

Document date
[Document date]

Confidentiality level
[Confidentiality level]

specifications. For other products, verification shall be carried out in accordance with levels 1–4 in “AMA Anläggning” code YE. If no level requirement is specified, verification shall be carried out to at least level 4.

For all items where inspection or surveying cannot be carried out retrospectively, e.g. excavation bottoms and underground pipes, the client must be given the opportunity to be present during the inspection in good time, but at least 5 working days before the work is carried out.

Inspection/Geodetic surveying

See OTB-mät, TLS4110-20GD-052-30-0_0-0001.

Inspection/Material handling

Soil transported to a reception facility shall be sampled to the extent specified by the contracted reception facility.

In the event of excavation in an area where the MKM guideline value is exceeded, the contractor shall carry out an environmental inspection in the form of sampling in accordance with an agreement with the client.

The samples shall be analysed for at least the following parameters: metals, polycyclic aromatic hydrocarbons, aliphatic hydrocarbons, aromatic hydrocarbons and polychlorinated biphenyls.

If excavation involves sulphide and sulphate soil, the excavated material must be checked for sulphur content. Soil with a sulphur content of more than 600 mg/kg/DM, an iron/sulphur ratio of less than 60 and a pH lower than 5 must be disposed of by an approved reception facility.

Sampling must be carried out in accordance with SGF Report 2:2013. The quality level for field and laboratory investigations must be based on mechanical cleaning of the sampling equipment and the exclusion of duplicate samples.

An accredited laboratory must be engaged and standardised analysis must be carried out.

A monitoring programme to identify the presence of elevated levels of contaminants shall be established.

Sampling, analysis and classification of soil must be carried out on soil that has been confirmed or is suspected to be contaminated.

The scope and execution shall be in accordance with the sampling programme drawn up by the contractor.

During excavation, the contractor shall inspect the soil visually and by smell. If contamination or contaminated soil is suspected, excavation shall be immediately halted within the affected part of the area and the client contacted.

Inspection/Environment

The Contractor shall draw up a draft monitoring programme concerning discharges to water. In the monitoring programme, the Contractor shall describe how the performance requirements and monitoring requirements set out in the tender documentation, “Chapter C1. Existing land and environment/Surface water”, are addressed and complied with. The programme shall describe the implementation, scope, measurement frequency, documentation and reporting of the monitoring. Relevant monitoring parameters covering flows, levels, turbidity and chemical quality shall be provided by the Client. The draft monitoring programme shall be drawn up in close consultation with the Client.

The client shall carry out monitoring of environmental impacts outside the work area.

Created by
[Created by]
Case number
[Case number]

Document date
[Document date]

Confidentiality level
[Confidentiality level]

Monitoring/Hydrogeology

The contractor shall draw up a monitoring programme for self-monitoring of the impact on groundwater, setting out and describing critical hydrogeological aspects and checks for functionality and safety. The monitoring programme shall describe the measurement of relevant control values, including implementation, measurement frequency, scope, documentation and reporting.

The client shall carry out and provide measurements outside the work area regarding environmental impact.

The contractor shall coordinate its groundwater level monitoring activities with the client and its monitoring programme.

Control/Construction in adjacent areas

A control plan for works related to the establishment of vegetation during construction and the warranty period shall be drawn up, specifying which checks and inspections are to be carried out. The plan shall also specify the stages of vegetation management that are to be documented in text and photographs.

At the warranty inspection, 100% establishment must have been achieved on slopes.

Created by
[Created by]
Case number
[Case number]

Document date
[Document date]

Confidentiality level
[Confidentiality level]

C. EXISTING LAND, ENVIRONMENT AND CONSTRUCTION

C1. Existing land and environment

Scope

Descriptions of the existing land and environment are based on environmental impact assessments relating to the railway plans for the Sjösa-Skavsta (from km 63+300) and Skavsta-Stavsjö sections. Full documentation will be provided upon signing of the contract.

General description of the railway infrastructure

Djälp–Tortorp (km 63+300–69+400)

The contract works begin just west of the Djälp farm at km 63+324. The railway runs on an embankment past Lövhagen. At Lövhagen, the railway crosses a private road via a bridge. West of Lövhagen, the railway then crosses Road 52 and the TGOJ line via a landscape bridge. At the bridge's western abutment, the new railway line transitions to running on an embankment. At km 65+507, a passageway is being constructed under the railway line.

The underpass serves as a wildlife and recreational passage and provides access to a property north of the tracks.

Tortorp–Hälladal (km 69+400–73+000)

From Tortorp and westwards, the new railway runs alternately on an embankment and in a cutting to adapt to the terrain. At km 70+251, a wildlife passage is being constructed under the Ostlänken, which also facilitates access for outdoor recreation. Through the valley at Hälladal, the railway runs on a landscape bridge, partly because there is a risk of flooding at the outlet of Lake Rinkeby. The elevated alignment is also advantageous for preserving agricultural land, enabling passage for people and animals, providing clearance over roads, and avoiding works in watercourses. In the western part of the valley, the railway transitions into a high embankment. The embankments at both ends of the bridge are designed to blend naturally into the landscape.

Romarängen–Vik (km 73+000–76+500)

The East Link continues alternately on embankments and in cuttings between Romarängen and Vik. Road crossings will be constructed for two private roads, at km 74+002 and at Haga at km 75+681 respectively.

Gammelsta–Höglunda (km 76+500–80+500)

At the start of this section, km 76+620–77+000, the railway is laid on an embankment with long cuttings on both sides. At Gammelsta and the junction with road 216 at approximately km 77+390, the new railway is constructed on a landscape bridge and passes over Gammelstabäcken and a private road. The railway continues through a cutting and then on through the woodland area on an embankment, with embankments constructed on both sides of the line between km 78+540 and 78+690. Further west, the railway runs mainly on a low embankment.

Furthermore, at Höglunda there is a dip in the terrain and a wildlife underpass is being constructed beneath the railway to allow wildlife to pass through.

Ålberga Bruk–Simonstorp (km 80+500–84+500)

Created by
[Created by]
Case number
[Case number]

Document date
[Document date]

Confidentiality level
[Confidentiality level]

Road 537 crosses the railway via a bridge where the lines intersect. At Ålberga, the railway passes south of the industrial estate on a landscape bridge over the valley. The landscape bridge is co-located with the existing bridge over the E4 and also allows passage under the new railway for people and animals. At Ålberga works, the settlement is protected from noise by the construction of noise barriers on either side of the landscape bridge's northern abutments and by the erection of a noise barrier on the bridge itself. At km 82+875, the railway crosses a private road at Långkärr via a bridge. Further west, the railway crosses the old Stavsjö–Krokek road. The road is diverted over a short stretch and crosses diagonally over the railway via a bridge, allowing the original route to be retained. The old road is of national interest for its cultural heritage (D 58), and the aim of this designation is to preserve the various historical road features found along the route. The road must remain passable and retain its adaptation to the terrain.

Lilla Källa–Sågkärret outlet (km 84+500–88+000)

The railway continues alternately on embankments and in cuttings. For the area near the Vretaån river, the alignment has been adapted to minimise the impact on natural values and groundwater resources. At the junction with road 534 and the Vretaån river, the railway is routed over a landscape bridge. The outlet of Sågkärret is also crossed via a railway bridge. North of Stavsjö, a road bridge is being constructed over the railway for the so-called Nunnebanan, a private road at km 87+795 that serves as both a cycle path and a walking trail.

Sågkärret–Smedbygget (km 88+000–91+730)

Three underpasses are being constructed within the area. The first underpass is being built at the outlet of Sågkärret at km 88+326 and allows access for outdoor recreation along the eastern side of the watercourse. Further west, the railway alternates between embankments and cuttings. At Rosenberg, at km 89+745, the railway crosses a private road, the old Stavsjö–Krokek road and the Sörmlandsleden trail via a bridge, and at km 90+300 a wildlife crossing for large game is being constructed. The railway continues to alternate between embankments and cuttings until the end of the contract area at km 91+730, where the Kolmård contract begins.

General description of the land and environment

The landscape in the eastern part of the railway line, between Aspedal and Nystugan, is characterised by a flat, gently undulating agricultural landscape with a few scattered farms. To the far east lies the well-preserved farm environment at Tortorp, and the valuable archaeological site at Hasselbacken with remains from several historical periods. To the west, the cultural landscape is characterised by the agricultural land around Nystugan, Hälladal and Harvetorp, which has remained largely intact since the end of the 19th century.

The area between Rinkebysjön and Ålberga is characterised by a hilly forested landscape. South of Valingeskogen lies Kiladalen, which has been an important transport route since the Bronze Age, when the valley was a sea inlet. On the forested hills lie a number of Early and Late Stone Age settlements. Eastern Kiladalen was heavily settled during the Late Iron Age, as indicated by several farm names ending in -sta and the adjacent small burial grounds in the woodland. A number of smaller farm and croft environments of cultural-historical value can be found along the route, such as Kärrbol, which dates back to the 17th century. In the Ålbergaån valley lies a culturally and historically interesting industrial site. Hydropower has been utilised here since the mid-17th century.

Between Kila and Stavsjö, the railway passes through a mosaic-like rift valley landscape in the eastern part and a high-lying forest plateau in the western part. At Vretaån, the railway crosses the site of national cultural heritage interest known as the Old Stavsjö–Krokek Road. The road, which is still partly in use, has a long history dating

Created by
[Created by]
Case number
[Case number]

Document date
[Document date]

Confidentiality level
[Confidentiality level]

back to at least the Middle Ages. The area is home primarily to a few small crofts, which are now mainly used as holiday homes. South of the railway area lay Stavsjö Ironworks, with roots in the 17th century, which was one of the more important ironworks in Sörmland. The ironworks' operations have left a clear mark on the surrounding landscape.

The landscape is dominated mainly by woodland, although there are small patches of cultivated land. The natural values of the woodland and cultivated landscape are generally moderate, with the exception of those woodland areas affected by high groundwater levels, where natural values are often higher. The natural values of the forest are relatively evenly distributed along the route, but an area with higher natural values is found furthest to the west.

The natural values of the agricultural landscape are mainly concentrated in Hälladal, west of Gammelstabäcken and around Vretaån. Several biotope protection areas are found here, and along Vretaån there is a pasture with high natural value.

To the south of the route flows the Vretaån–Kilaån, a Natura 2000 site featuring a valuable watercourse and surrounding riparian woodland. This watercourse, as well as several of its tributaries, is crossed by the railway line. Around the Vretaån, Ålbergaån and Gammelstabäcken there are riparian woodlands, often of high natural value. In the western part of the route, there is a large mire complex comprising both open and forested mires of high natural value; most of the route's trees worthy of protection are also found in this area. Other trees worthy of protection are relatively well distributed along the route and occur in various types of natural environments.

As the majority of the planned land use consists of managed forest, most of the surrounding area comprises relatively species-poor natural environments; however, in the eastern section, long-eared owls and resting geese and swans are present. In the far west, there is a population of smooth snakes. Red-listed species are present along the entire route.

Function

Unless otherwise specified for existing land and the environment outside the work area, it must not be affected by the design and construction of the facility in question and must retain its functions and qualities during construction and after completion.

All temporarily used land areas must be restored to the same type of natural land as before.

The Swedish Transport Administration has agreements with other government agencies and contracts with external organisations regarding access to geodata, map products and services for the purpose of providing a basis for production or the exercise of public authority in accordance with the Swedish Transport Administration's commitments.

Where there is a need for supporting data covered by an agreement or contract (LM, SGU, municipality), such data must be accessed via a call-off. Call-offs and the provision of material must take place with the involvement of the client. The material provided may only be used and processed for the duration of the assignment.

Documents subject to copyright must always be credited to the author/owner and copywriter, for example © Lantmäteriet, Geodatasamverkan for products from Lantmäteriet.

Inspection

The contractor's inspection programme and associated inspection plans must detail the necessary checks to verify that the existing land and environment outside the work area retain their functions and qualities during execution and after completion. The inspection must include a joint, minuted

Created by
 [Created by]
Case number
 [Case number]

Document date
 [Document date]

Confidentiality level
 [Confidentiality level]

inspection no later than 3 weeks before the start of the contract and after the work has been completed. The client and affected landowners shall be given the opportunity to participate.

C1. Existing land and environment / Public water supply

Scope

The railway lies within the secondary protection zone of the Högåsen water protection area, from the eastern boundary of the contract area to km 65+300 (Figure C1.1). The water protection area and associated protection regulations for the Högåsen water supply were established by the Södermanland County Administrative Board in June 2016 (ref. no. 513-4121-2012). The Högåsen waterworks has been designated as a site of national interest for water supply facilities (Swedish Agency for Marine and Water Management, ref. no. 2850-2016, decision 16 September 2016). The Högåsen waterworks abstracts water from the Larslundsmalmen-Nyköping groundwater body.

The groundwater body is assessed as having good quantitative status, whilst its chemical status is unsatisfactory due to traces of, among other things, pesticides. Environmental quality standards require that the groundwater body maintain good quantitative status and achieve good chemical status by 2027, with the exception of certain chemical substances.

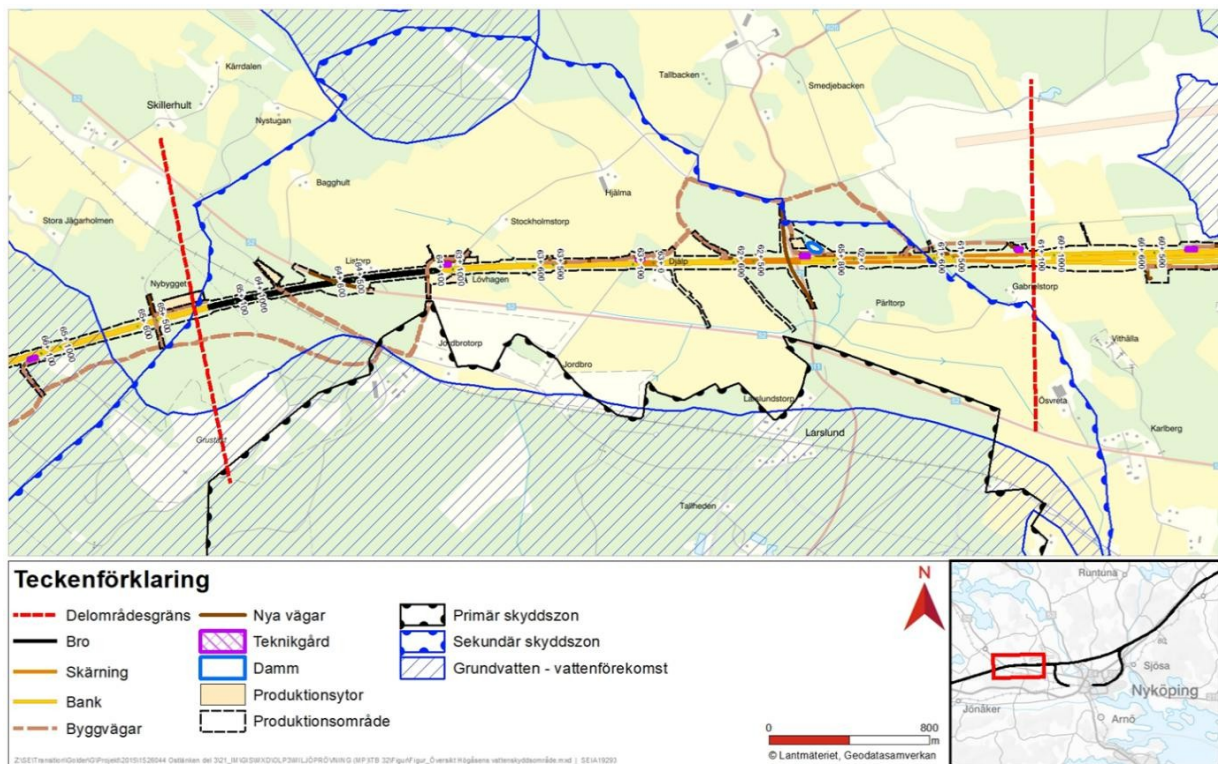

Figure C1.1. Water protection area for the Högåsen waterworks (Södermanland County Administrative Board, ref. no. 513-4121-2012, 15 June 2016)

Function

The water source and groundwater body must not be affected during the contract period or after completion in terms of quality or quantity, unless otherwise permitted by a permit, exemption or notification. Applicable protection regulations must be followed and the necessary permits must be applied for.

Created by
[Created by]
Case number
[Case number]

Document date
[Document date]

Confidentiality level
[Confidentiality level]

Certain measures within the Högåsen water protection area are subject to a permit requirement. The Client has obtained such permits for measures directly related to water activities subject to permit assessment. In all other respects, it is the Contractor's responsibility to obtain the necessary permits. Permits for measures within the water protection area must be applied for from Nyköping Municipality.

Harmful substances from the ground reinforcement must not leak into groundwater sources. Products and structures used for ground reinforcement must not leach harmful substances and impair the chemical status of groundwater sources.

C1. Existing land and environment / Private water source

Scope

There are a number of private dug and drilled wells within the work area. These will be purchased and taken out of service at the start of the contract.

Within the area affected by groundwater lowering, there are also a large number of private water sources, both dug and drilled. Monitoring of the impact on these is managed by the client within the framework of the water activity monitoring programme.

C1. Existing land and environment / Rock engineering

Scope

An overview of the bedrock and structures in the area is provided by the SGU's bedrock map for the relevant survey area. See <https://apps.sgu.se/geolagret> and the description accompanying the map; see [Description of the bedrock quality map of the southern parts of Södermanland](#).

A description of the geotechnical conditions for the contract is provided in the Technical Memorandum on Geotechnics and MUR (Soil Investigation Report) with accompanying drawings and appendices. Full documentation will be provided upon signing of the construction contract.

Rock engineering conditions and investigations are summarised below.

The landscape in Nyköping municipality is varied. Geological processes have created a landscape consisting of rift valleys and ridges formed by rock. The larger valleys run mainly in a north-west to south-east direction, meaning they are largely perpendicular to the planned railway line. With the route now decided, this means that major valleys will be crossed via bridges or embankments, and that rock cuttings will be carried out through elevated sections consisting of rock without any major continuous earth-filled valleys.

The bedrock within the study area for the Ostlänken Nyköping sub-project forms part of a high, long-weathered mountain range. The oldest sedimentary and volcanic surface rocks were folded and intruded by deep-seated rocks, granitoids. Basaltic magma also intruded into the bedrock in connection with fracture formation and solidified as veins, diabase. The rocks were metamorphosed under high pressure and high temperature, resulting in, among other things, vein formation (veined gneiss). As a result of this metamorphism, it is in some places very difficult to determine the original rock type.

At a later stage, the bedrock was again intruded by magma of granitic composition, which solidified into a typically grey, massive granite. Following this, extension in the bedrock led to the formation of fractures, and diabase veins intruded, mainly into north-western fractures.

Created by
[Created by]
Case number
[Case number]

Document date
[Document date]

Confidentiality level
[Confidentiality level]

In those parts of the contract area covered by SH32 (km 63–69), granitic gneiss predominates, but with minor elements of metasedimentary rock, metavolcanic rock and granite. Within SH 33 (km 69–92), Skavsta–Stavsjö, massive granite dominates in the eastern section from approximately kilometre 69+400 to approximately kilometre 74+500. West of the granite and up to Ålberga, at approximately kilometre 83+000, the bedrock consists entirely of granitic gneiss. In the westernmost part of the section, the bedrock here also consists of these rock types, granitic gneiss and massive granite, in roughly equal proportions. Smaller areas of metasedimentary rock are also present. In addition, over a short stretch around kilometre 83, there are diabase veins running in a north-west to south-east direction; the extent and width of these diabase veins are somewhat unclear as the degree of exposure in the area is low. There are no active quarrying or mining operations within the area in question.

Rock cuttings will be carried out along several sections of the new main line. In most cases, the route for the majority of the larger rock cuttings passes through the highest parts of the hills, which means that there will be double-sided cuttings, i.e. rock cuttings on both sides of the tracks. The deepest rock cuttings on the section in question will be approximately 17 metres.

Analyses of rock material quality and sulphur content have been carried out on material from drill cores taken from core boreholes drilled in representative rock types and in areas with major rock extraction. Within the current area, four core boreholes have been drilled in two sub-areas and in two rock types.

The rock engineering conditions for rock cuttings and other types of rock excavation are generally assessed as good. The rock material within the project is assessed as largely meeting the requirements for material type 1 according to TK Geo 13; the majority of the rock masses consist of rock type 1. The rock material is assessed as being suitable for various purposes within the project, such as embankments, noise barriers and landscaping.

C1. Existing land and environment / Geotechnics

Scope

The main geological features of the area are shown on the SGU's soil map, <https://apps.sgu.se/kartvisare/kartvisare-jordarter-25-100.html>

A description of the geotechnical conditions for the contract is provided in the Technical Memorandum on Geotechnics and the MUR (Soil Investigation Report) with associated drawings and appendices. Full information will be provided upon signing of the contract.

Geotechnical conditions and investigations are summarised below.

Km 63+300–69+400

The soil layers consist of clay and silt at the top and, below that, friction soil over bedrock up to approximately km 64+500. Soil depths vary between approximately 5 and 25 metres. The bedrock surface has been determined by soil and rock sounding to be at a depth of between approximately 10–35 metres below ground level.

From approximately km 64+500 to the end of the section, the soil layers consist of alternating friction layers with abundant silt above bedrock. The railway crosses the glacial river deposit at Larslundsmalmen/Stigtomtamalmen. The geological structure of the glacial river deposits is highly complex.

Created by
[Created by]
Case number
[Case number]

Document date
[Document date]

Confidentiality level
[Confidentiality level]

In many parts of the deposits, sand and silt dominate, whilst in others stony gravel prevails. Moraine overlying, interbedded within, and underlying the glacial river sediments has been observed in several places. Large parts of the coarse-grained material are overlain, particularly to the east, by fine sediments. Elements of finer-grained material also occur between coarse-grained layers and even at great depths.

In the river sections, the material often consists of gravel, whilst sand and fine sand generally dominate in other parts. Within the ore body, there are, or have been, several gravel pits. Alluvial deposits (gravel and sand) occur in association with the glacial river deposits. The alluvial deposits are often underlain by clay. Soil probing has determined that the bedrock lies at a depth of between approximately 15 and 50 metres below ground level.

Km 69+400–89+000

The area contains both woodland and arable land. The section consists of alternating elevated areas with firm ground and valleys with loose soil. The firm ground consists of exposed rock or friction soil overlying rock. The friction soil consists of sand and moraine. According to soil soundings, the thickness ranges from 0 to 20 metres.

The loose soil layers in the valleys consist of clay and silt, with a thickness of approximately 3–15 metres. The soil is susceptible to erosion in places.

Organic soil in the form of peat and silt is present. The peat layer is usually up to approximately four metres thick. The silt layer is up to approximately two metres thick. Between approximately km 72+150 and km 72+300, there is a peat bog with a thickness of approximately four metres.

From km 86+500 and westwards, the terrain is mainly woodland.

km 89+000–91+730

The area consists mainly of forest land. The section alternates between elevated areas of solid ground and depressions with peat bogs. The solid ground consists of exposed rock and thin layers of moraine overlying the rock. Peat occurs in places along the entire section and has a maximum thickness of approximately five metres.

Function

The geotechnical conditions reported in the MUR and associated appendices apply as a prerequisite. Deviations in the geotechnical conditions must be compiled and reported to the client for a decision on adjustment. For reported bedrock levels at a depth > 15 m from ground level, deviations of +/- 5 m from the bedrock level are not subject to adjustment. Where rock levels are reported at a depth of ≤ 15 m from ground level, a deviation of rock level of +/- 2 m applies. Furthermore, the selected methods must be sufficiently robust to withstand the same deviation in rock level.

C1. Existing land and environment / Hydrogeology

Scope

A description of the hydrogeological conditions for the contract is set out in the Technical Memorandum on Hydrogeology and the MUR (Geotechnical Investigation Report) with associated drawings and appendices. Full information will be provided upon signing of the contract

Hydrogeological conditions and investigations along the contract route are summarised below.

Created by
[Created by]
Case number
[Case number]

Document date
[Document date]

Confidentiality level
[Confidentiality level]

The facility passes over Larslundsmalmen-Nyköping (VISS EU_CD: SE651659-156091). The groundwater body constitutes a protected area for drinking water abstraction in accordance with Article 7 of the Water Framework Directive and is subject to the requirements of the Drinking Water Directive. The groundwater body is also classified as nationally important for water supply (Class 1 according to SGU).

The facility passes through the water protection area for the Högåsen water source. The water protection area and associated protection regulations for the Högåsen water source were revised and adopted by the Södermanland County Administrative Board in June 2016 (ref. no. 513-4121-2012). The Högåsen waterworks has been designated as a site of national interest for water supply facilities (Swedish Agency for Marine and Water Management ref. no. 2850-2016, decision 16 September 2016).

Three hydrogeological type environments recur within the contract area. The type environments have been developed to assist in the overall description of the route. However, within areas that generally fit into a type environment, deviations of varying degrees occur regularly. Areas that do not fit into any type environment also occur along the route.

The three hydrogeological typical environments are called:

- A. Hilly upland area** – An area with high-altitude bedrock topography. Consists of upland areas with fragmented, heterogeneous geology, featuring alternating outcrops of rock, moraine and smaller areas of clay soil.
- B. Clay-covered valley** – An area dominated by clay-filled valleys with thick layers of soil.
- C. Elevated/exposed glaciofluvial formation** – The area consists of ridges or moraines of glaciofluvial origin. The soil consists of various compositions of sand, silt and gravel deposits.

A more detailed description of the hydrogeological environments can be found in the Technical Memorandum on Hydrogeology.

Högåsen, km 63+300–approx. km 65+300

Hydrogeologically, the eastern parts can be described as the ‘Clay-covered valley’ environment and, from approximately km 64+200, as the ‘Exposed glacial river formation’.

The proposed route passes over a flat area with clay and clayey silt overlying thin layers of friction soil on bedrock. The sequence of soil layers within this area may provide conditions for separate groundwater reservoirs. The groundwater pressure level in the lower aquifer at the passage through the depression at Djälp and Lövhagen is approximately +31–32, which is just below ground level.

Runoff flows towards the Larslundsmalmen-Nyköping groundwater body and the Högåsen water supply in the south. The track line passes through the secondary protection zone for the water supply from the start of the contract at km 63+300 and 65+300.

Larslundsmalmen, approximately km 65+300 – approximately km 69+400

This sub-area is characterised by a large, elongated glacial river deposit, stretching from Lake Yngaren in the north-west to Stadsfjärden south-east of Nyköping. The glacial river deposit forms a groundwater reservoir with good to excellent extraction potential. The glacial river deposit is a designated groundwater body known as Larslundsmalmen-Nyköping.

The soil layers in Larslundsmalmen have a complex structure and are assessed as having the potential to form separate groundwater reservoirs locally. In parts of the section crossing

Created by
[Created by]
Case number
[Case number]

Document date
[Document date]

Confidentiality level
[Confidentiality level]

the groundwater body (km approx. 65+700 – 68+100), glacial river material is exposed. The groundwater level in the main aquifer is approximately +32. A gravitational watershed occurs in the aquifer at the level of the Stigtomtamalmen gravel pit southeast of the railway.

The area west of approximately km 68+000 is characterised by a flat clay plain with several protruding, partly moraine-covered rocky outcrops. It is considered likely that the clay layers are underlain by a more or less continuous layer of glacial river material which is in hydraulic contact with the Larslundsmalmen deposit to the east.

The direction of groundwater flow at the relevant track alignment crossing over Larslundsmalmen is towards Lake Yngaren (surface water body Yngaren SE653034-154584) to the north-west. The topographical variation of the glacial river deposits means that the distance between the ground surface and the groundwater table varies from eight metres in the eastern part to two metres in the western part of the track alignment's passage through the groundwater body.

Hasselbacken, approximately km 69+400–71+300

This section consists of a flat clay plain with several protruding, partly moraine-covered rocky outcrops. The rocky outcrops are mainly located as three flat ridges running NW-SE at Tortorp, Hasselbacken and at the end of the section at approximately km 71+300.

The plain areas mainly consist of the typical environment of a clay-covered valley, with surface soil layers of glacial clay or silt. The glacial river sediments along the section form part of the large glacial river deposit known as Larslundsmalmen.

The groundwater pressure level in the depression west of Hasselbacken is around ground level, with artesian levels present. Other groundwater pressure levels in the area have been found to range from just below ground level to approximately three metres below the surface.

Hälladal, approximately km 71+300–73+300

This section is characterised by a large valley running in a north-west to south-east direction. Three smaller valleys running in a north-north-east to south-south-west direction join this valley: two in the western part from the south and one in the eastern part from the north. At the bottom of the valley runs the Björnbäcken stream, which drains Lake Kvarnsjön and Lake Rinkebysjön to the south-east towards the Kilaån river.

The sub-area is characterised by the hydrogeological environments of clay-covered valleys and hilly upland areas. The groundwater pressure level in the valleys varies from just below the ground surface to six metres below the ground surface, with artesian levels occurring in the valley at Hälla.

Gammelsta, approximately km 73+300–81+000

This section covers the upland area between the Björnbäcken valley and the Ålbergaån valley. The upland area, which is mainly situated at +45 to +60 metres, is dominated by gently undulating, forested terrain with many small bogs and is intersected by a number of smaller valleys that generally consist of clay.

The section can mainly be described as a hydrogeological environment of a hilly area, with exposed rock or rock covered by a thin layer of moraine, in places overlain by peat. Clay is present in the lower-lying areas. The soil depth is generally less than five metres, but in a number of valleys, geotechnical investigations indicate a soil depth of approximately 10–15 metres.

Groundwater levels within the section are assessed to follow the general pattern described for an elevated area. Levels are between 0–2 metres below ground level. In the clay-filled valleys, artesian groundwater pressure levels have also been measured.

Created by
[Created by]
Case number
[Case number]

Document date
[Document date]

Confidentiality level
[Confidentiality level]

Ålberga, approximately km 81+100–81+800

This short section covers the passage through the Ålbergaån valley. Groundwater flow follows the steep topography. Regular measurements in three groundwater pipes in the valley adjacent to the track line's passage through the Ålbergaån indicate levels in a lower aquifer of 1–4 metres below ground level.

The groundwater aquifer at Ålbergaån is in contact with surface water.

Källtorp, approximately km 81+800–85+300

This section covers the area between the Ålbergaån and Vretaån valleys. Towards both valleys, the terrain slopes relatively steeply, whilst in between it is relatively flat and gently undulating. In the Vretaån valley, to the west and south, there is an elongated glacial river deposit, which is described in more detail in the next section.

The section can mainly be described as a hydrogeological environment of a hilly upland area; it is dominated by surface rock, with moraine in places overlain by peat. In the lower-lying areas, clay is generally present. In the easternmost part of the section, the track line passes through a large peat bog underlain by clay. The direction of groundwater flow follows the topography from the watersheds on the ridges down to the valley and, within the water-bearing glacial river deposits, continues in the direction of the valley towards the south-east. Groundwater levels in the glacial river deposits have been measured in observation wells at approximately 5–7 metres below ground level, with significant variations in the positive level of the groundwater surface, ranging from approximately +25 to +35.

The groundwater level in the soil layers is generally 0–2 metres below ground level along the track alignment. Artesian levels occur in the clay-covered valleys.

Vretaån approximately km 85+300–87+000

This section includes the passage through the Vretaån valley. The Natura 2000-protected Vretaån meanders along the valley floor. In the Vretaån valley, there is a glacial river deposit extending from Korsbäcken in the south to Lake Virilängen in the north. The glacial river deposit is a groundwater body designated by the Geological Survey of Sweden (SE651446-153738). The Vretaån also constitutes a Natura 2000 site.

The direction of groundwater flow follows the topography from the watersheds on the ridges down into the valley and, within the water-bearing glacial river deposits, continues in the direction of the valley towards the south-east.

Groundwater levels in the glacial river deposits have been measured in observation wells at approximately 5–7 metres below ground level. As the ground level varies along this section, this results in significant variations in the groundwater table elevation between approximately +25 and +35 metres, which is generally below the planned railway alignment.

Stavsjö, approximately km 87+000–91+730

This section runs entirely through what can be described as typical Kolmård forests (a hilly, elevated area). The entire section comprises an elevated area with gently undulating terrain, featuring small valleys and bogs between the hills. The Vretaån river crosses this section at approximately km 88+350.

The groundwater table generally lies 1–2 metres below ground level in the moraine-covered hilly areas, whilst in the lower-lying marshes and bogs, the groundwater table is at ground level. The undulating topography also results locally in a fairly complex flow pattern for the groundwater down towards the low points. Within the section, there are several minor local groundwater and surface water divides in various directions. Together with shallow soil depths, this means that the groundwater reservoirs are small.

Created by
[Created by]
Case number
[Case number]

Document date
[Document date]

Confidentiality level
[Confidentiality level]

Function

The hydrogeological conditions must not be altered in terms of quality or quantity in such a way as to harm public or private interests, unless permitted under a water activity licence in accordance with the Environmental Code.

When constructing site preparation and storage areas over groundwater bodies, measures must be taken to prevent the spread of contamination to the groundwater bodies if there is no clay layer of sufficient thickness.

Existing groundwater pipes must be protected as far as possible, and any pipes that are damaged or removed must be replaced by the contractor in consultation with the client.

Monitoring

If the hydrogeological conditions are likely to change in terms of quality or quantity, the necessary investigations must be carried out and a hydrogeological report drawn up to verify that it is clear that neither public nor private interests are harmed.

An accredited laboratory must be engaged and standardised analysis carried out.

C1. Existing land and environment / Hydrogeology / Larslundsmalmen groundwater body

Scope

Larslundsmalmen is a glacial river deposit consisting of sand, extending in an east-west direction between Nyköping and Lake Yngaren. The glacial river deposit forms a large groundwater reservoir which is a designated and protected groundwater body named Larslundsmalmen-Nyköping (SE651659-156091). The railway line runs diagonally through the western parts of the body. The groundwater body is assessed as having good quantitative status, whilst its chemical status is unsatisfactory due to traces of, among other things, pesticides. Environmental quality standards require the groundwater body to maintain good quantitative status and achieve good chemical status by 2027, with the exception of certain chemical substances. The groundwater reservoir is also assessed as having good to excellent abstraction potential, estimated at 25–125 l/s in the northern longitudinal half of the deposit. In the southern longitudinal half, the abstraction potential is assessed as good (1–5 l/s).

The Larslundsmalmen-Nyköping groundwater body is protected under Article 7 of the Water Framework Directive, which states that water bodies used for abstraction of a certain quantity, or reserved for future abstraction, are protected to ensure the availability of good-quality water. The groundwater body is also classified as nationally important for water supply (Class 1 according to SGU). The classification is based on high abstraction potential and the groundwater body's significance for the surrounding population structure. Parts of the Larslundsmalmen-Nyköping groundwater body are protected by the Högåsen water protection area (NVR-ID 2004748), see Figure C1.2. The railway passes through the secondary protection zone of the water protection area.

Created by
[Created by]
Case number
[Case number]

Document date
[Document date]

Confidentiality level
[Confidentiality level]

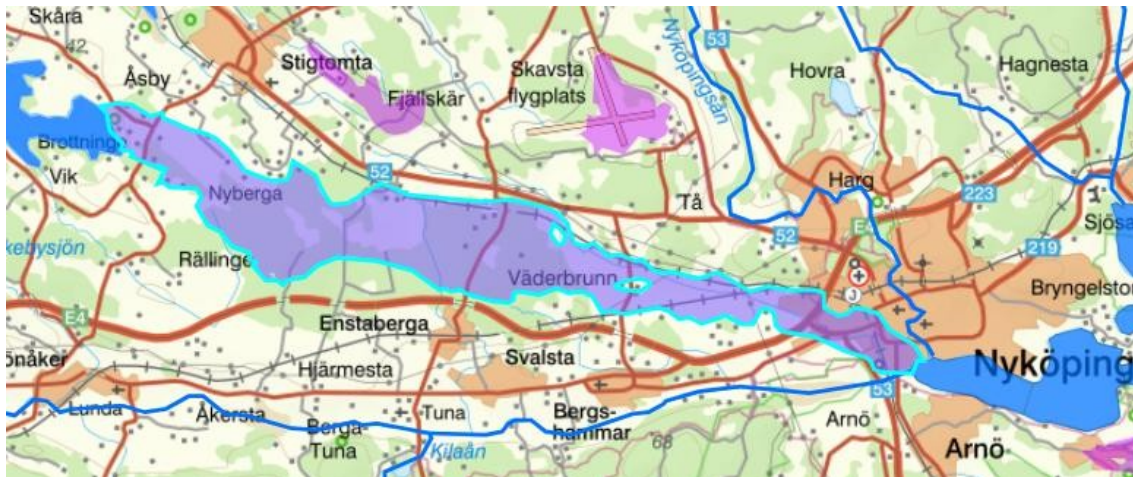

Figure C1.2. The extent of Larslundsmalmen (SE651659-156091) between Lake Yngaren and Nyköping

C1. Existing land and environment / Hydrogeology / Vretaån groundwater body

In the Vretaån valley, there is a glacial river deposit extending from Korsbäcken in the south to Lake Virlången in the north. The glacial river deposit is a groundwater body designated by the Geological Survey of Sweden (SE651446-153738), see Figure C1.3. The groundwater body is subject to environmental quality standards and currently achieves good quantitative and chemical status. The railway will involve a shallow cut through the glacial river deposits, west of the Vretaån. A shallow cut has been sought during the route selection process to minimise the risk of impact on the groundwater body. The eastern part of the cut, facing the Vretaån, will lie above the general groundwater level. Road 534, which runs along the western side of the Vretaån and also passes under the E4, will need to be moved slightly westwards prior to the construction of the railway bridge over the Vretaån. Relocating the road will involve encroachment into the glacial river deposits. Within the glacial river deposits, there is a moraine ridge that acts as a watershed for groundwater flows.

The road will not affect the moraine ridge and therefore no change in groundwater flows to the Vretaån is anticipated. The risk of deterioration in the quantitative status of the water body has been assessed as negligible.

Created by
[Created by]
Case number
[Case number]

Document date
[Document date]

Confidentiality level
[Confidentiality level]



Figure C1.3. Vretaån groundwater body (SE651446-153738) extent between Lake Yngaren and Nyköping

Function

Groundwater flows to the Kilaån-Vretaån Natura 2000 site must not be altered in such a way that the inflow or the hydrology of the watercourse is adversely affected.

C1. Existing land and environment / Agriculture and forestry

Scope

Descriptions of agriculture and forestry are set out in the environmental impact assessments accompanying the railway plans for the Sjösa-Skavsta (from km 63+300) and Skavsta-Stavsjö sections. Full information will be provided upon signing the contract.

The conditions are outlined below.

Contiguous agricultural land is found, for example, along the eastern boundary of the project area at Djälp and Lövhagen, south-east of Lake Yngaren and in the Vretaån valley; smaller farming units are scattered throughout the valleys or in wooded areas. To the south of the corridor lies the E4 motorway, which currently acts largely as a barrier to the large-scale agricultural landscape in the Kilaån valley. A cattle farm is located at Backgården. Horse farms are situated at Ålberga and one at Smedbygget, west of Stavsjö. The corridor crosses pastureland of high natural value. Such areas are found west of the Vretaån river.

Created by
[Created by]
Case number
[Case number]

Document date
[Document date]

Confidentiality level
[Confidentiality level]

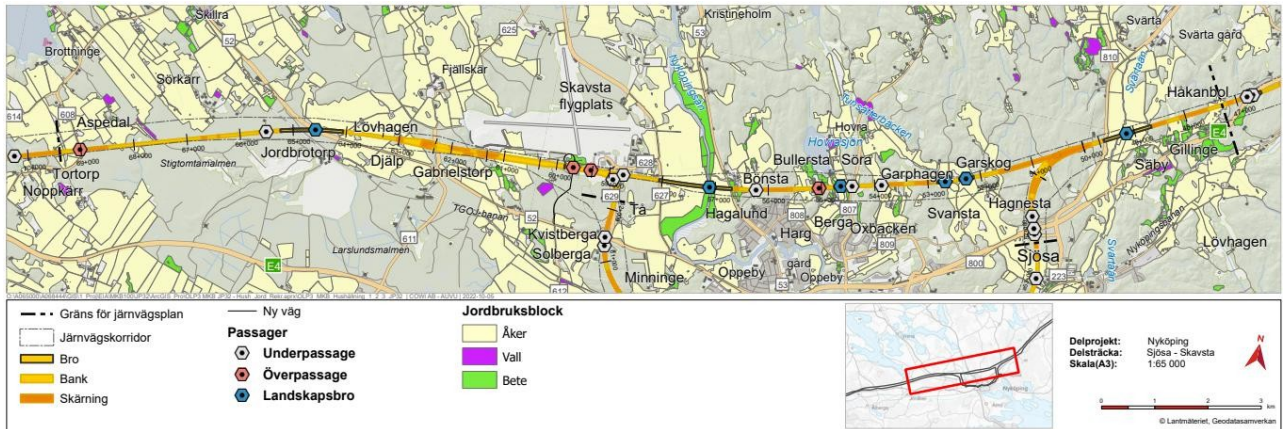

Figure C1.4. Agricultural blocks and livestock farms within the Sjösa–Skavsta railway plan. Areas west of km 63+300 at the Djälp farm are included in the Ålberga contract. An agricultural block is a defined area that meets the EU’s requirements for agricultural land. Agricultural land refers to arable land and pasture.

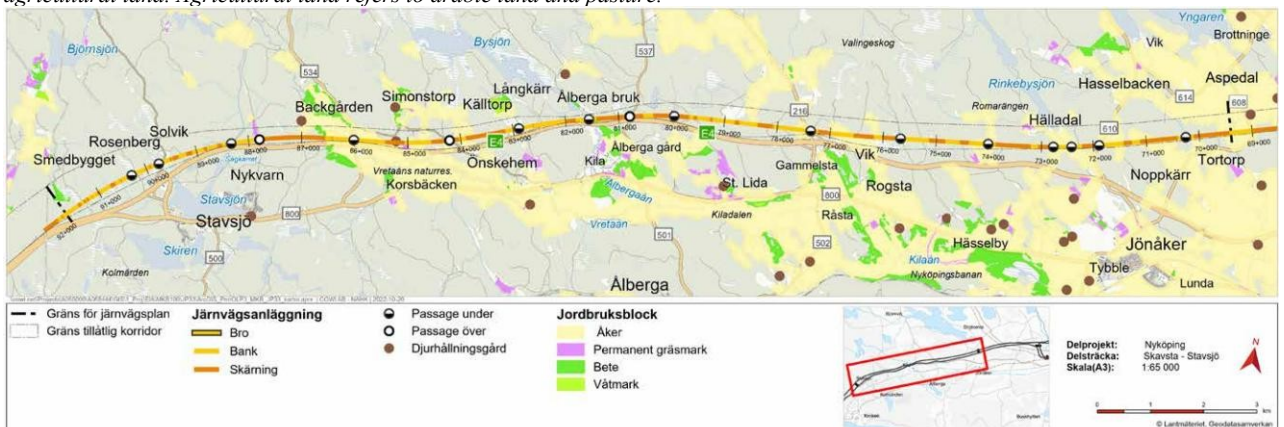

Figure C1.4. Agricultural blocks and livestock farms within the Skavsta–Stavsjö railway route. The entire section is included in the Ålberga contract.

Contiguous forest land is found along most of the section. The forests are mainly coniferous, dominated by spruce and pine with some deciduous trees. The vast majority of areas are heavily influenced by modern forestry. Within the corridor, there are both areas that have been felled relatively recently and areas with large timber stocks.

Created by
[Created by]
Case number
[Case number]

Document date
[Document date]

Confidentiality level
[Confidentiality level]

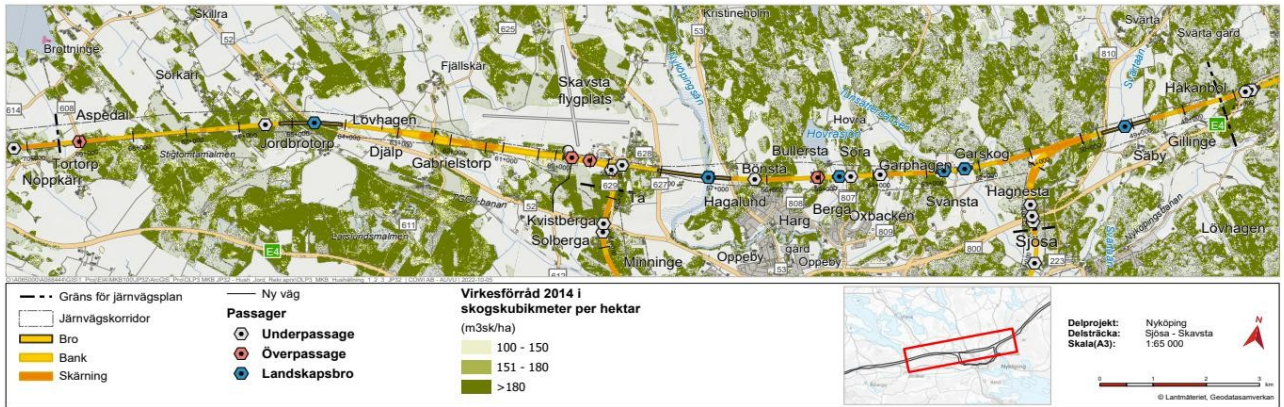

Figure C1.5. Forest productivity within the Sjösa–Skavsta railway plan. Areas west of km 63+300 at the Djälp farm are included in the Ålberga contract.

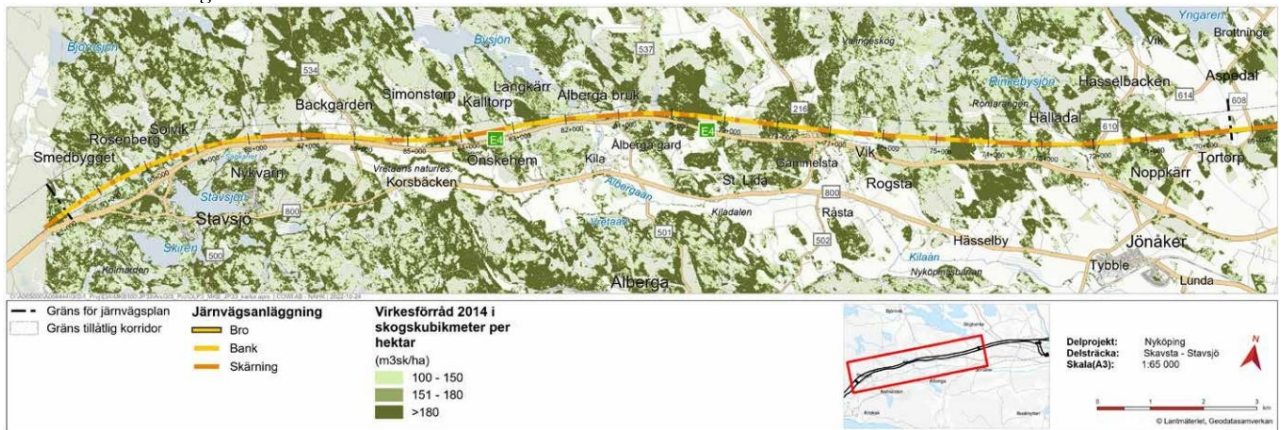

Figure C1.6. Site quality of forest land within the Skavsta-Stavsjö railway plan. The entire section is included in the Ålberga contract.

Function

Access to agricultural or forestry land must continue to be possible via existing or new connections during both the construction and operational phases.

Any necessary felling within the work area shall be carried out by and shall be the responsibility of the contractor.

Clearing and removal of logging residues left behind shall be carried out by and shall be the responsibility of the contractor. Stumps shall be removed and shall be the responsibility of the contractor.

The removal of GROT (branches and tops) shall be carried out for energy recovery. The contractor shall ascertain the extent of the felling.

When working on arable land within areas to be restored, topsoil that is removed must be kept separate from the subsoil. When restoring the arable land, the topsoil must be returned to the extent necessary to maintain the original growing conditions and topsoil depths.

Created by
[Created by]
Case number
[Case number]

Document date
[Document date]

Confidentiality level
[Confidentiality level]

When restoring areas affected by temporary access roads, site preparation areas and storage sites on arable land, measures must be taken to the extent necessary to maintain the original growing conditions and topsoil depths.

Inspection

Inspection of the function and extent of accessibility for agriculture and forestry (roads) affected shall be carried out through a joint, minuted inspection no later than 3 weeks before the start of the contract and after the work has been completed. The client and affected landowners shall be given the opportunity to participate.

Inspection of the execution of restoration work carried out on arable land shall take place through a joint, minuted inspection after the work has been completed. The client and affected landowners shall be given the opportunity to participate.

C1. Existing land and environment/Cultural environment

Scope

Ancient monuments are protected under the Cultural Environment Act 1988:950. The East Link passes through a mixed landscape of fields, woodland and pasture, as well as older settlements of cultural value. Parts of the road network are very old, and its route and character provide information about historical movement patterns and how the landscape has been used. The open agricultural landscape offers the opportunity to see and understand the connections and structures of the cultural environment. This means that views and sightlines are important for the legibility of the cultural environment.

Current land use, with boundaries between land types such as forest, arable land and pasture, tells the story of how the land has been used historically. As historical functions have been maintained, the landscape's historical development remains largely clearly legible.

The old Stavsjö-Krokek road (D58) is an older road route in Nyköping municipality, classified as being of national interest under Chapter 3, Section 6 of the Environmental Code.

Known ancient monuments and other types of remains within the railway plan's permanent and temporary land claims, as registered in the Cultural Environment Register, will be managed by the client and archaeologically investigated in accordance with Chapter 2 of the Cultural Environment Act.

Ancient monuments and other types of remains within the railway plan's land claims that were not previously known but are encountered during construction work, and which have therefore not been dealt with by the client, shall be dealt with by the contractor.

Function

At the start of the contract, the contractor shall receive the Instruction: Discovery of previously unknown ancient monuments and archaeological finds in connection with the construction phase of the East Link – Contractor/Supplier, TDOK 2024:0150. This sets out what the contractor must do if an ancient monument, an object resembling an ancient monument or a formation is encountered during the work.

C1. Existing land and environment/Cultural environment//Protection of ancient monuments and other remains outside the work area

Scope

Ancient monuments within the work area shall be investigated and removed by the client. Those ancient monuments that lie only partially within the land claim and therefore will not be investigated in their entirety in accordance with Chapter 2 the Cultural Heritage Act shall be fenced off for protection by the contractor. This also applies to ancient monuments which,

Created by
[Created by]
Case number
[Case number]

Document date
[Document date]

Confidentiality level
[Confidentiality level]

entirely lie outside the land claim but are nevertheless so close to the work area that they risk accidental damage during the construction phase.

Function

Existing ancient monuments, potential ancient monuments and other cultural heritage remains outside the work area must not be damaged, disturbed or affected in any way by the contractor's activities.

Protective fencing around ancient monuments must be erected along the boundary of the work area in accordance with instructions provided by the client. By law, an ancient monument is accompanied by a so-called ancient monument area, which is larger than the monument itself and constitutes a kind of protection zone. The section along the boundary of the work area that is to be fenced off must correspond to at least both the length of the individual ancient monument and its ancient monument area. A permit under Chapter 2 of the Cultural Environment Act may be required.

Inspection

Protective fencing must be inspected and, where necessary, maintained on an ongoing basis during the contract period by the Contractor.

Inspection of protective measures shall be described in the Contractor's environmental plan. When protective fencing is removed, the impact on and condition of the remains shall be assessed and compiled in a report. The report shall be provided to the Client.

C1. Existing land and environment / Cultural environment / Vibrations and buildings of cultural value

Function

Buildings of cultural and historical value within the area of influence must retain their functions and qualities during construction and after completion. Vibration-generating works shall be planned and carried out in such a way that nearby buildings of cultural and historical value are not damaged. The contractor shall report the selected production methods to the client and incorporate the results into the existing risk analysis in order to comply with the functional requirements for buildings of cultural and historical value regarding vibration-generating works and air shock waves.

The contractor shall, in the design documentation, set out the necessary protective measures to safeguard valuable cultural heritage buildings against damage. These shall be approved by the client. At the start of the contract, the contractor shall receive existing assessments of cultural values from the railway planning stage, covering some of the buildings concerned. Within the area affected by the Ålberga contract, no buildings or built-up areas have been identified as being sensitive to vibrations.

Inspection

Before and after blasting, sheet piling, piling, excavation and compaction, visual inspections of buildings and structures shall be carried out in accordance with Swedish Standard SS 460 48 60.

Inspections of the impact on buildings of cultural and historical value shall be carried out in accordance with the contractor's inspection programme for movement, deformation and vibrations. If the building is particularly sensitive, a site-specific inspection programme may be required.

Created by
[Created by]
Case number
[Case number]

Document date
[Document date]

Confidentiality level
[Confidentiality level]

The contractor's monitoring programme and associated monitoring plans shall set out the necessary checks to verify that buildings of cultural and historical value retain their functions and qualities during construction and after completion.

C1. Existing land and environment / Cultural environment / Roads of cultural value

Scope

The older network of gravel roads comprises roads which, by virtue of their route and character, possess cultural value. Cultural value in terms of a road's character is determined, for example, by its width, alignment in plan and profile, profile height, surface finish, ditches and relationship to the surrounding land.

The client will specify which roads with high cultural value are referred to above.

Function

Roads with high cultural value used for construction traffic must retain the cultural values associated with their route and character.

The client will specify the restrictions applicable to each road.

No heavy traffic may be driven on the Old Vreta-Krokek Road, ID D58, a site of national interest for cultural heritage conservation, **outside the specified production area**. Heavy traffic is defined in this requirement as any vehicle with a total weight exceeding 3,500 kg.

C1. Existing land and environment / Landscape and built-up areas

Scope

Descriptions of the landscape and character areas are set out in the environmental impact assessments accompanying the railway plans for the Sjösa-Skavsta (from km 63+300) and Skavsta-Stavsjö sections. Full information will be provided upon signing the contract.

The conditions are described in general terms below.

The flat agricultural and cultural landscape west of Nyköping

The area consists of a characteristic agricultural landscape with farms scattered amongst the fields. The landscape is crossed by the existing TGOJ railway line and Road 52, which runs in a north-west to south-east direction. Within the area there are villages and farms of historical and cultural significance, as well as numerous ancient monuments. Within this character area, there is a value area shaped by a high classification of the assessment aspects: hydrogeology, cultural environment and land-based industries. The railway affects a relatively small part of the character area, which is already affected by the TGOJ line and Road 52, and the area is therefore assessed as having moderate sensitivity to the planned railway construction.

Stigtomta and Larslundsmalmen

The agricultural landscape is interspersed with wooded gravel ridges. The forested area is important for recreation and outdoor activities and is used for activities such as mushroom and berry picking. A number of interesting plant and animal species are associated with the site's ecological conditions. There is a fair amount of wildlife movement in the area. The dense forest means that sightlines are short, and the railway will not be visually noticeable from a distance.

The flat agricultural landscape at Aspedal

Created by
[Created by]
Case number
[Case number]

Document date
[Document date]

Confidentiality level
[Confidentiality level]

Between the wooded gravel ridges to the east and Valingskogen to the west, a flat agricultural landscape stretches out. A few farms are scattered across the open landscape, including Aspedal Farm, which has a long history and contributes to the area's identity. The surrounding forest is relatively uninhabited. Road 608 runs through the area in a north–south direction between Road 52 and the E4. Within the character area, there is a value area shaped by a high classification of the assessment aspects of cultural environment, landscape character and land-based industries. The project only affects the edge of the character area. The section in question affects only a small part of this character area at its easternmost point.

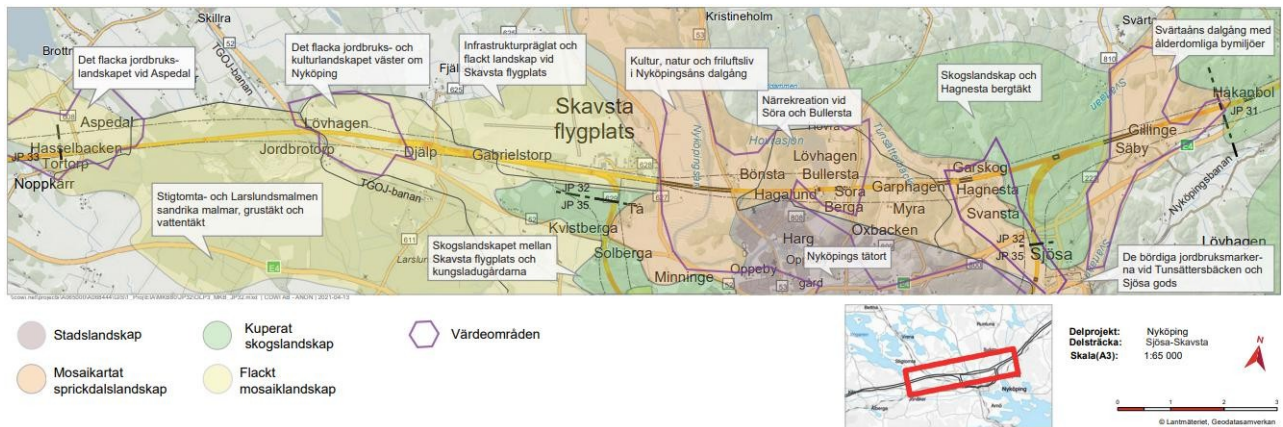

Figure C1.6. Identified landscape types within the railway plan for Sjösa-Skavsta. Areas west of km 63+300 at the Djälp farm are included in the Ålberga contract.

Valingskogen: recreation and outdoor activities

Valingskogen is one of Nyköping municipality's larger, unspoiled forest areas, which is largely undeveloped. The landscape is homogeneous with few distinct landscape spaces and views. The area is well-used for recreation and outdoor activities, and there is a bathing spot at Rinkebysjön. South of Rinkebysjön, the forest opens up somewhat; here lies the village of Hälladal and a number of scattered farms. Within the area, there is a value area around Hälladal that has been shaped by a high rating of the assessment criteria relating to land-based industries, recreation and outdoor activities, and landscape character. Due to its enclosed nature, large parts of the character area are relatively resilient to the railway line from a visual perspective.

The fragmented forest landscape between the Ålbergaån and Vretaån

The Ålbergaån and Vretaån rivers flow down from the north towards the Kiladalen valley, and between the river valleys a forested landscape spreads out, broken up by small areas of cultivated land and scattered settlements.

The valleys consist of many components such as settlements, farmland, water and forest. Settlements and farmland also have a distinct cultural-historical character. The E4 runs parallel to the corridor. The Ålbergaån is part of the Kilaån area of national interest for nature conservation. The Ålbergaån is surrounded by a hilly and small-scale landscape, and the differences in elevation adjacent to the river are marked. The complexity is relatively high, and the slopes feature both scattered settlements and farmland. In the northern part of the valley lies Ålberga Bruk, dating from the 17th century, which is still in use today. The river is crossed by the E4, resulting in a landscape of slightly lower quality immediately adjacent to the road.

The Vretaån is also part of the Kilaån area of national interest for nature conservation and is a Natura 2000 site. The Vretaån valley is part of the larger Kilaån valley, which stretches all the way to Nyköping. The E4 runs close to the railway corridor, and from the E4 there are views southwards towards the Kila Valley. Along the E4,

Created by
[Created by]
Case number
[Case number]

Document date
[Document date]

Confidentiality level
[Confidentiality level]

the area is given a slightly lower landscape value than the rest of the area. The historic road environment of the Old Stavsjö–Krokek Road, which is of national interest for cultural heritage conservation, crosses the valley near the E4. The Old Road is still used for traffic and, on certain stretches, also for cycling, known as the Näckrosleden. The rivers offer high landscape values.

The area includes a site of special value along the Ålbergaån and Vretaån rivers, shaped by high ratings in the assessment criteria of cultural heritage, landscape, land-based industries, and recreation and outdoor life.

The upland forest and cultural landscape characterised by Stavsjö Bruk

The area is a contiguous, relatively flat forested area covered in coniferous woodland situated on a natural plateau. Openings in the dense coniferous forest create small, enclosed landscape spaces with their own distinct character. The area is partly covered by a site of national interest for cultural heritage conservation, the Old Stavsjö–Krokek Road (D58).

North-west of Stavsjö lies Rosenberg, whose farm buildings have cultural heritage value with links to Stavsjö Bruk. The farm buildings are situated in an open landscape clearly framed by the surrounding forest. The buildings consist of small, cottage-like houses. The Sörmlandsleden trail, which is Sweden’s first lowland trail and highly valuable for recreation and outdoor life, also runs through the area.

The area includes a high-value area at Rosenberg, characterised by high ratings for the assessment criteria of cultural heritage, natural environment, landscape, recreation and outdoor activities, and land-based industries.

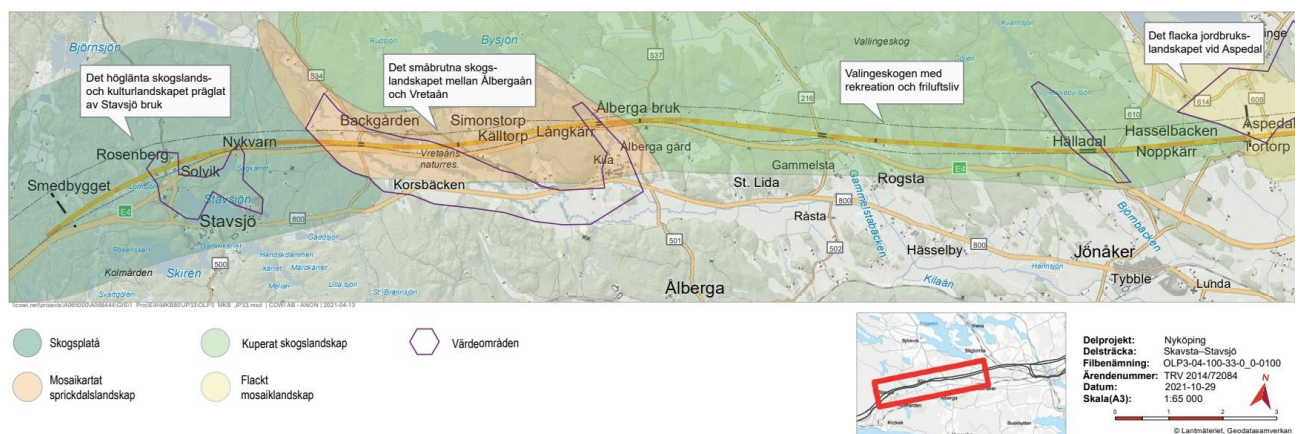

Figure C1.7. Identified landscape types within the Skavsta-Stavsjö railway plan, which forms part of the Ålberga contract.

C1. Existing land and environment / Land and water pollution

Scope

A description of contaminated land areas within the contract area is provided in the memorandum on contaminated areas, together with associated drawings and appendices. Full documentation will be provided upon signing of the contract.

Created by
 [Created by]
Case number
 [Case number]

Document date
 [Document date]

Confidentiality level
 [Confidentiality level]

The conditions are described in general terms below.

Along the section, eight potentially contaminated sites have been identified, of which two have been investigated in more detail: the Larslund gravel pit and Ålberga works. For the other identified sites, investigations have not been deemed necessary. The potentially contaminated areas in relation to the track alignment are shown in the images below

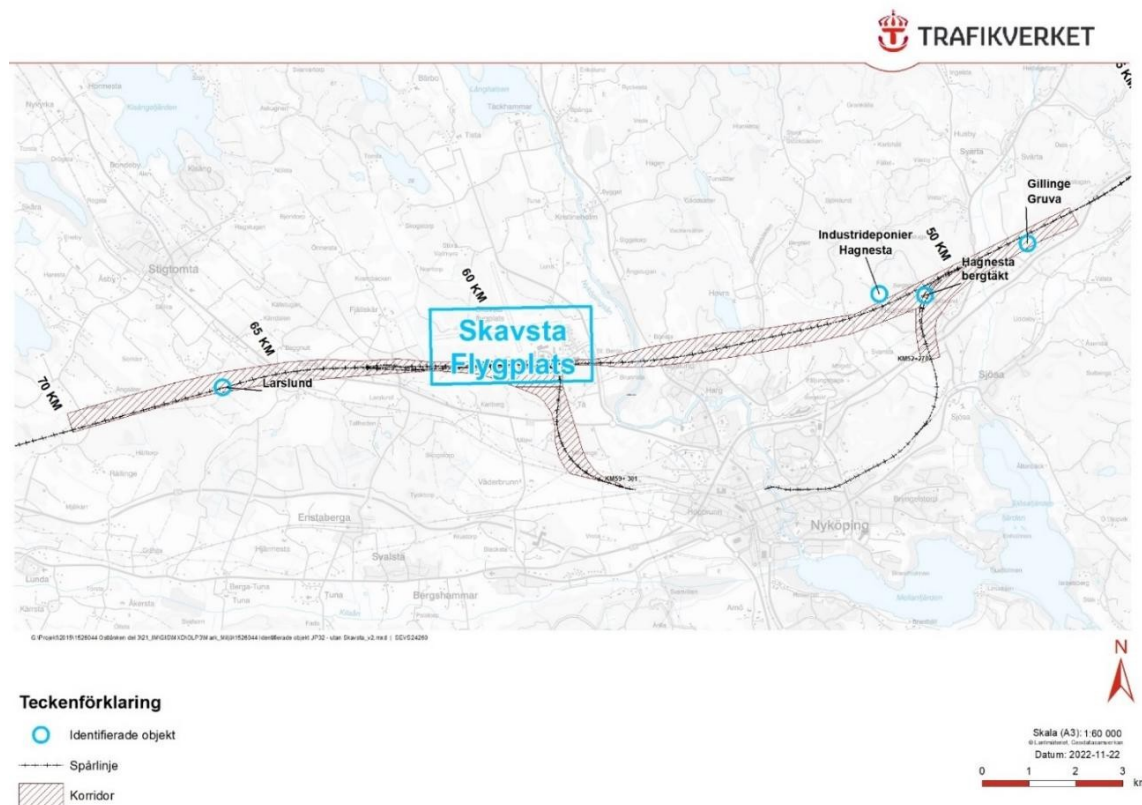

Figure C1.8. Identified potentially contaminated sites within JP 32. Note that only the westernmost site, the gravel pit at Larslund, lies within the Ålberga construction area.

Soil samples from the area around the Larslund gravel pit have been analysed for metals, aliphatic compounds, aromatic compounds, BTEX and PAHs. All analysed samples show concentrations below the guideline values for sensitive land use (KM). Based on the analysis results obtained, no further investigations or measures are deemed necessary at the gravel pit.

The contamination at Ålberga Bruk, an old ironworks with operations involving iron, steel and manufacturing, has been assigned risk class three according to the MIFO register (EBH 132172). Operations ceased in the 1870s and today traces of the activity can be seen in the form of slag found in the surrounding area along the Ålbergaån river. Environmental investigations carried out have not revealed any contamination levels exceeding the Swedish Environmental Protection Agency's general guideline values for sensitive land use, KM. The assessment is that the contaminants remaining in the soil are likely to be difficult to leach, and the potential for dispersion is moderate as the soil within the works area consists largely of rock and moraine. The dispersion and

Created by
[Created by]
Case number
[Case number]

Document date
[Document date]

Confidentiality level
[Confidentiality level]

extent of any contamination are assessed as limited. No further soil sampling is deemed necessary prior to the construction phase. See (C1.9)

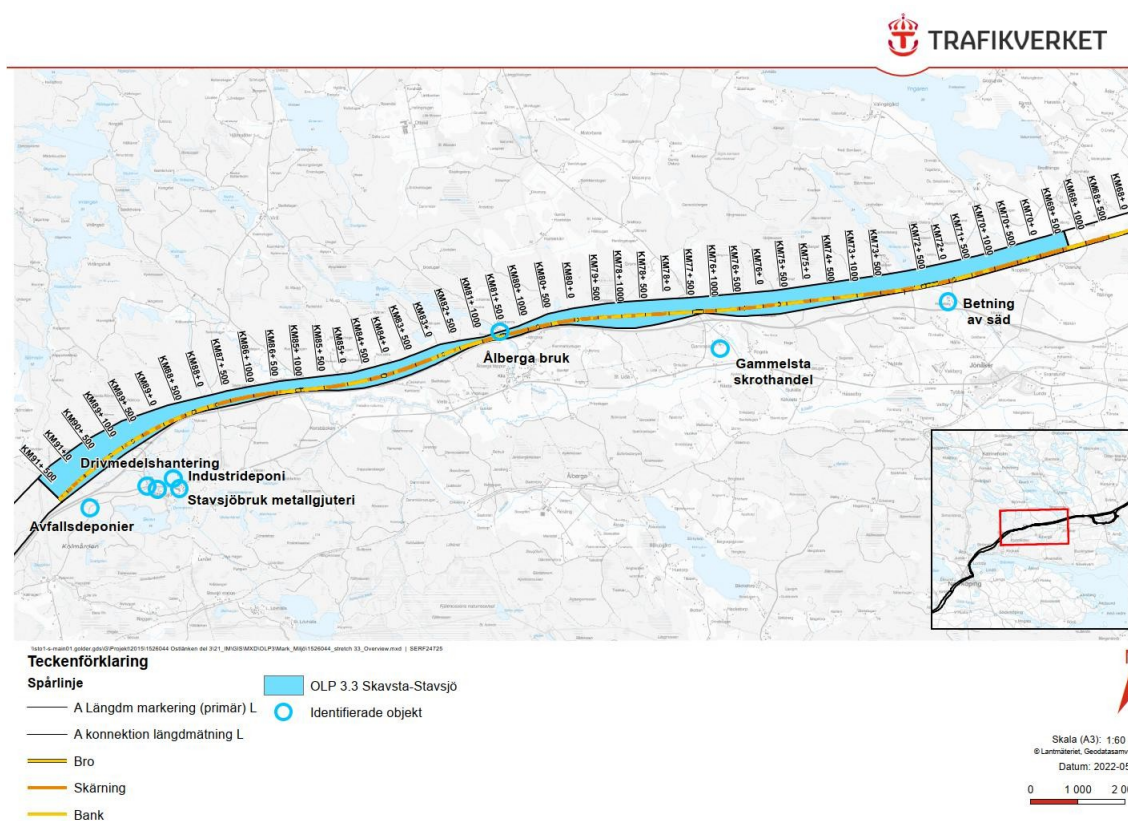

Figure C1.9. Identified potentially contaminated sites within JP 33. The entire area is covered by the Älberga contract.

Function

Known contamination and contamination discovered during the design or construction phase must be investigated and remediated by the contractor, unless otherwise specified. If the contamination may cause harm or nuisance to human health or the environment and the contamination situation requires remedial action, a notification in accordance with Section 28 of the Ordinance on Environmentally Hazardous Activities and Health Protection must be submitted to the supervisory authority for a decision. The contractor shall prepare the necessary documentation in consultation with the client.

C1. Existing land and environment / Land drainage works, ditches, etc.

Scope/ Surface water, ditches, etc.

The East Link passes several small ditches within the section km 63+300 – km 91+730, where the Älberga contract ends. For a description of the scope, function and monitoring of these, see C1. Existing land and environment/ Surface water

Created by
[Created by]
Case number
[Case number]

Document date
[Document date]

Confidentiality level
[Confidentiality level]

Scope/ Land drainage works

Existing land drainage schemes affected by the contract, as well as maps of water activities referred to in the text below, will be provided in full versions following the signing of the contract.

A general description of the conditions is provided below.

There are 7 land drainage systems that will be more or less affected by the contract. The land drainage systems include both pipelines, culverts and open ditches/watercourses that will need to be used to convey drainage from the railway towards the receiving water body.

The descriptions below refer to ID numbers for water operations and discharge points. The locations of the water operations and discharge points are shown on the map appendices accompanying the application for a water operations permit.

From east to west, the land drainage projects are as follows:

Created by
 [Created by]
 Case number
 [Case number]

Document date
 [Document date]

Confidentiality level
 [Confidentiality level]

Jordbron–Djelp tf, 1944 ID 387

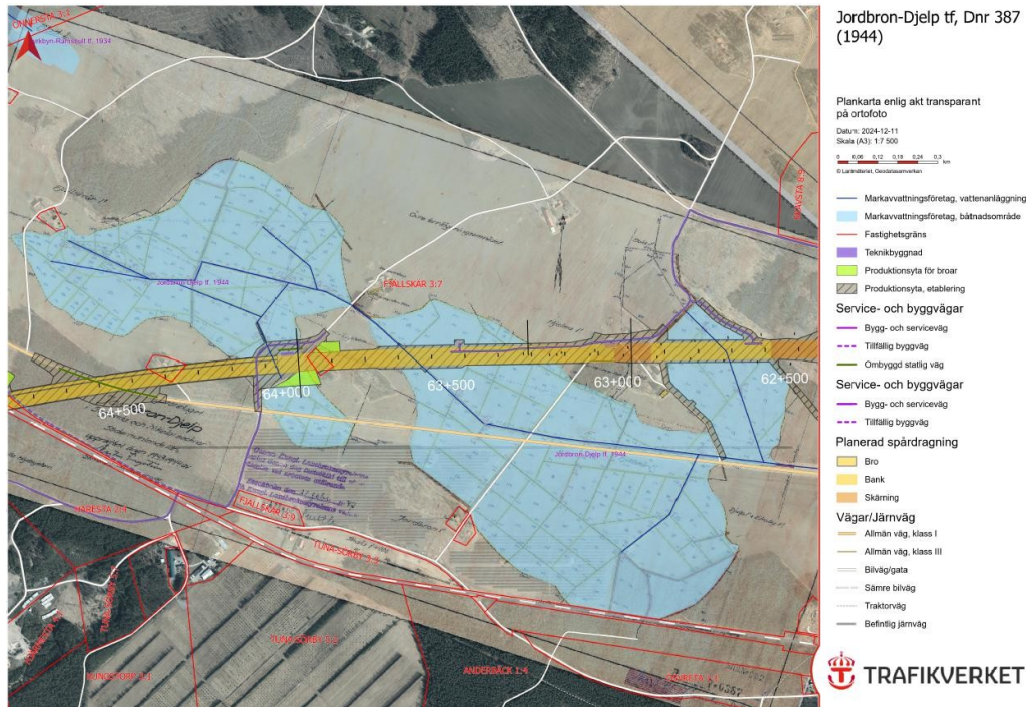

Figure C1.9. Overview map showing the Jordbron–Djelp tf land drainage project, 1944 (ID 387).

Jordbron–Djelp tf, ID 387 is a drainage project covering approximately 115 hectares, extending east-west for about 3.5 kilometres, see below. The largest part is situated north of road 52. The entire project is situated on arable land in strips, whilst the main drainage channel runs through a field ditch and flows from west to east into Idbäcken and on into Stadsfjärden.

The drainage project's main drainage channel passes under the railway in a culvert at km 63+650. To the west, the drainage system is affected by the railway in that the railway bridge foundations may be positioned where the existing pipeline is located, and the existing farmland drainage will need to be replaced with new drainage pipes outside the bridge foundations.

Drainage from the railway within the Ålberga contract area will be discharged into the drainage system at discharge points U32-46 and U32-47. At these points, the flow is estimated to increase by 1 and 2 per cent respectively.

Created by
[Created by]
Case number
[Case number]

Document date
[Document date]

Confidentiality level
[Confidentiality level]



Figure C1.10. Discharge points within the Ålberga contract to the land drainage contractor Jordbron–Djelp tf.

Ängsäter–Brottninge df, 1947 ID 447

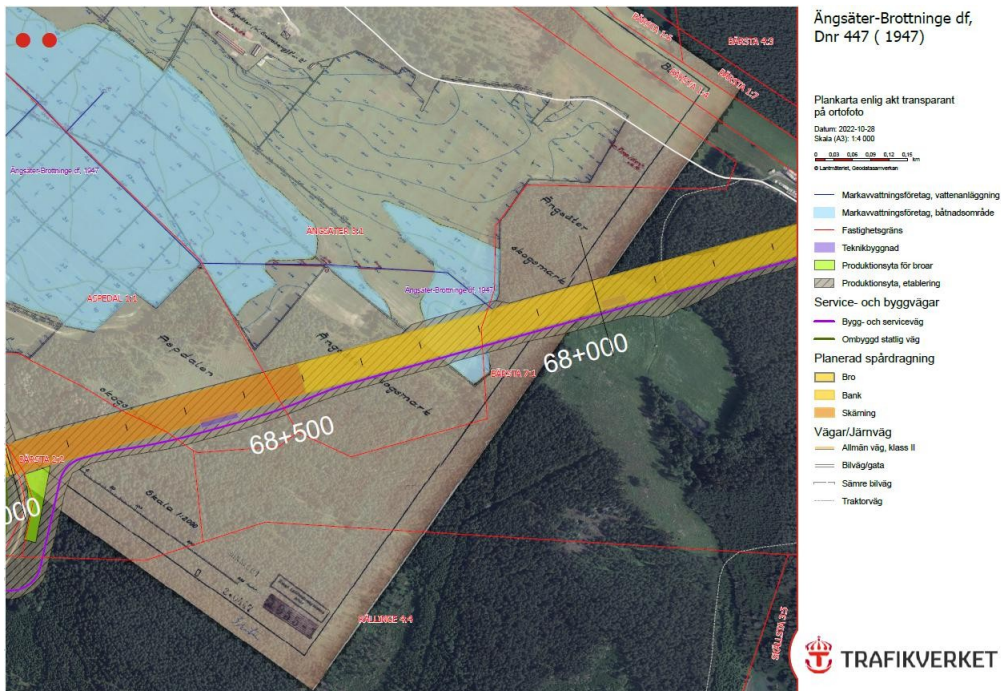

Figure C1.11. Overview map showing the Ängsäter–Brottninge df land drainage scheme, 1947 (ID 447).

Ängsäter–Brottninge df is a drainage project covering approximately 28 hectares, with water flowing through pipes from the south and north to Lake Yngaren via Lake Långhalsen to the Nyköping River and finally out into Stadsfjärden. The project is situated on arable land with likely smaller arable land drainage pipes connected to it.

Created by
[Created by]
Case number
[Case number]

Document date
[Document date]

Confidentiality level
[Confidentiality level]

The southern part of the drainage system and its starting point will be crossed by the railway, with approximately 0.5 hectares being cut off. This area will be drained into the railway's delayed drainage system and then channelled on to the main drainage channel of the drainage system. A ditch is culverted under the track at 68+300. The railway's drainage is delayed before discharge into the land drainage company's system.

The railway's drainage will be discharged into the company's system at discharge point U32-50 and is estimated to result in a 13 per cent increase in flow. U32-50 flows into an existing open ditch which is considered to have the capacity to accommodate the flow.

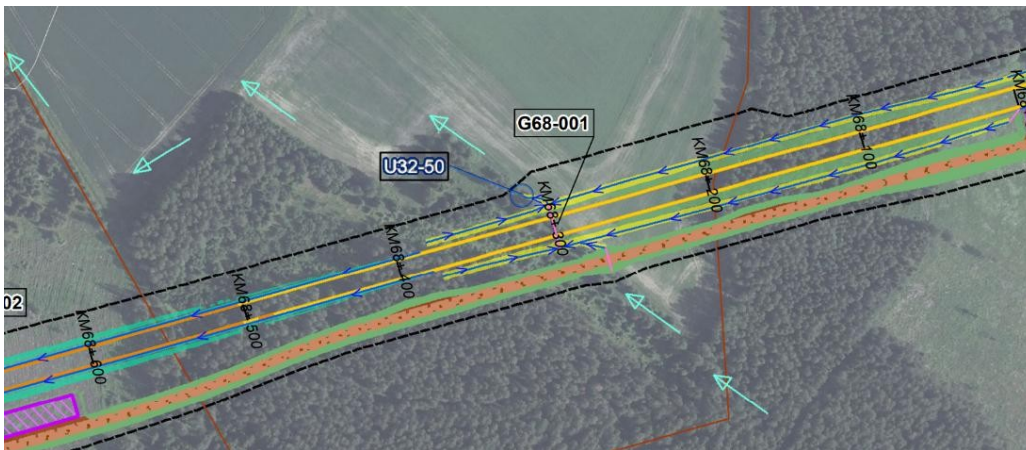

Figure C1.12. Discharge point to the Ängsäter–Brottninge temporary land drainage scheme.

Vik–Rällinge tf, 1946 ID 404

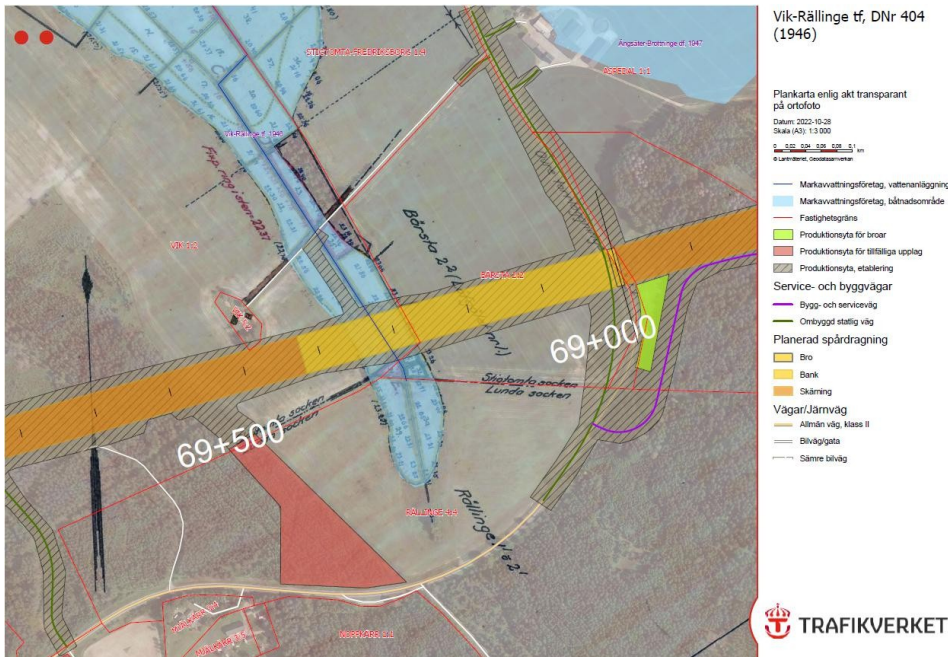

Figure C1.13. Overview map showing the Vik–Rällinge TF land drainage project (ID 404).

Created by
[Created by]
Case number
[Case number]

Document date
[Document date]

Confidentiality level
[Confidentiality level]

A drainage project covering approximately 30 ha, whose primary receiving water body is Lake Yngaren, through which the water flows and via the Vretaån river to Lake Långhalsen and on into the Nyköpingsån river, eventually emptying into Stadsfjärden. The project's water flows mainly through open ditches.

The southernmost part of the land drainage project is cut off because the two smaller tributaries south of the railway line need to be diverted through a new culvert under the railway line and further north. North of the railway line and on the western side of the existing ditch, a retention ditch will be constructed where the railway line's internal water is retained before discharge into the land drainage project.

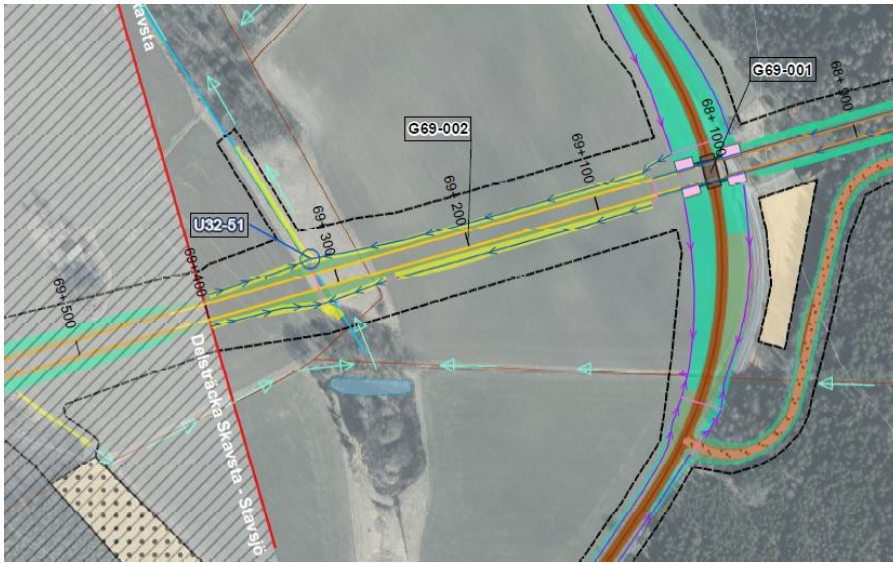

Figure Ci.14. Discharge point to the Vik-Rällinge TF land drainage system (ID 404).

Created by
 [Created by]
Case number
 [Case number]

Document date
 [Document date]

Confidentiality level
 [Confidentiality level]

Rällinge–Skällsta drainage project, 1956 ID 808

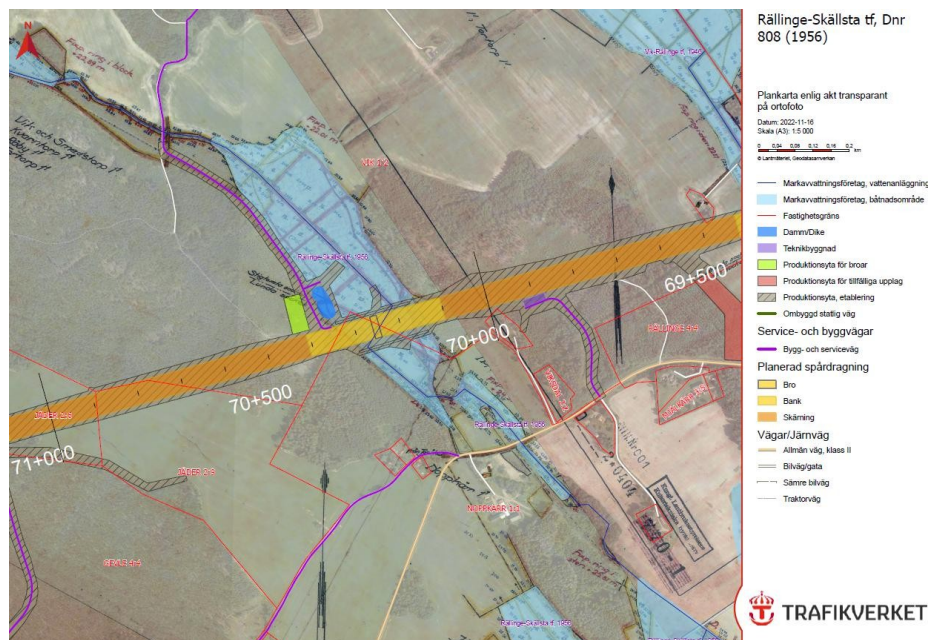

Figure C1.15. Overview map showing the Rällinge–Skällsta TF land drainage scheme (ID 808).

The railway crosses a land drainage project between km 70+150 and km 70+320. The land drainage project is a large drainage scheme covering approximately 125 ha. Most of the drainage from the project flows from the E4 in the south and northwards to Lake Yngaren as the receiving water body. To the south, the Jäder-Mjälkärr-Smedsta land drainage project (ID 436), covering approximately 28 ha, is connected. Both land drainage projects flow mainly through ditches and streams.

South of the railway, the land drainage company has a total catchment area of approximately 660 ha, and this will continue to flow northwards via the existing system.

The drainage scheme's main flow path will be relocated to a passage west of the current flow path via a wildlife crossing. To manage the drainage of the track, a retention pond will be constructed west of the crossing. The retained water from the retention pond will be connected northwards to the existing drainage channel and on to the existing receiving water body. Water from embankment drainage will be discharged onto the track via outlet point U33-03. Calculations indicate a flow increase at U33-03 of approximately 3%.

Created by
 [Created by]
Case number
 [Case number]

Document date
 [Document date]

Confidentiality level
 [Confidentiality level]

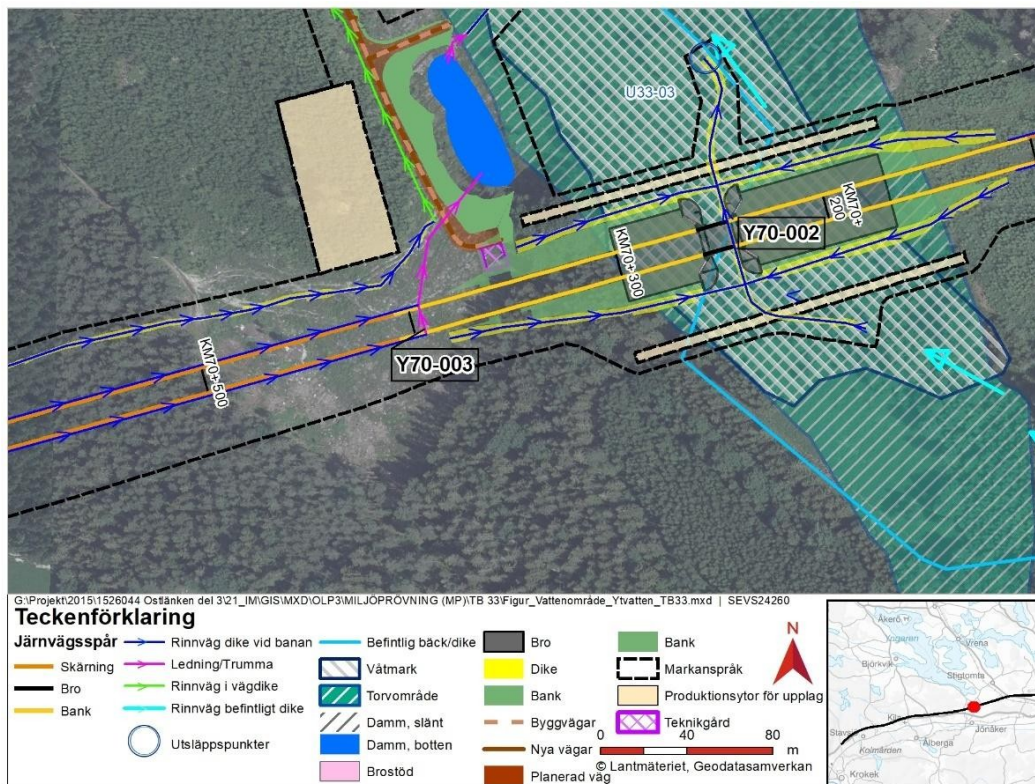

Figure C1.16. Discharge point to the Rällinge-Skällsta TF land drainage company.

Gävle, Nybble section, 1923 ID 103

The railway crosses a land drainage scheme between km 73+950 and km 74+300 (see Figure C1.17). The land drainage scheme is a drainage scheme covering approximately 22 ha, dating from 1923–1924. According to information from the County Administrative Board, the project is said to consist mainly or exclusively of open ditches, but these have probably been piped. Further information must therefore be obtained to gain a clearer picture of how the pipes are laid. The project is situated on arable land interspersed with nearby woodland and begins south of the E4.

The drainage route runs, from the E4 in the south, first northwards, then after approximately 800 m turns eastwards towards Rinkeby sjön, and then via Björnbacken southwards to Kilaån, finally flowing into Stadsfjärden.

Created by
 [Created by]
 Case number
 [Case number]

Document date
 [Document date]

Confidentiality level
 [Confidentiality level]

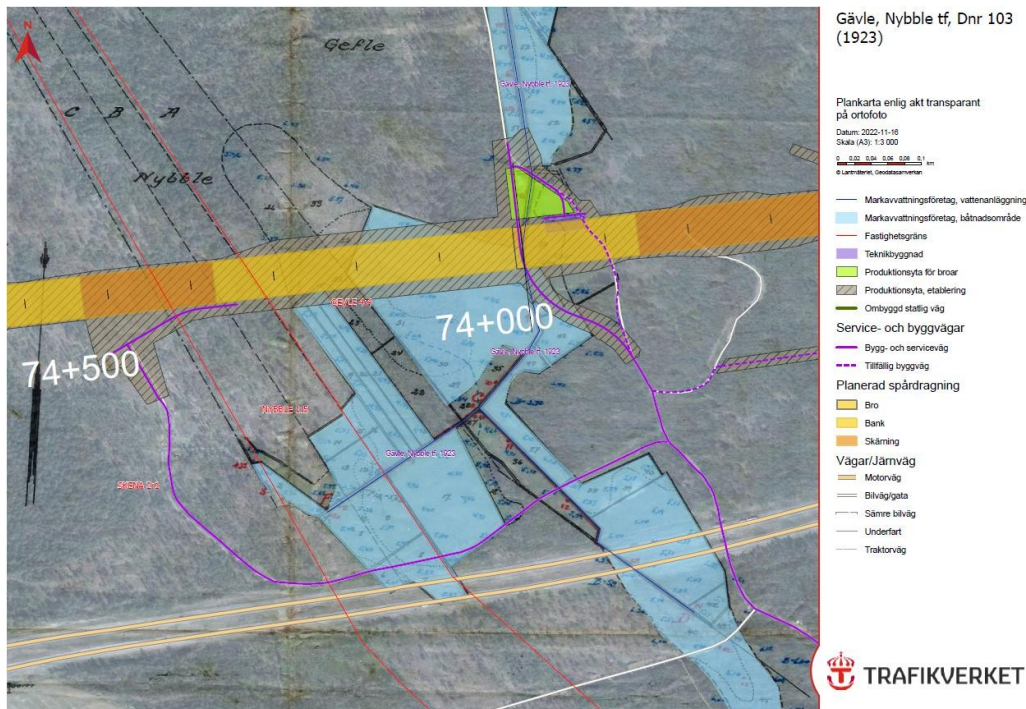

Figure C1.17. Overview map showing the Gävle, Nybble TF land drainage project (ID 103).

An area of approximately 7,500 m² is cut off north of the railway line. The drainage is planned to be rerouted on the northern side of the railway line and then connected to the existing watercourse to the north. In other parts of the project, a minor relocation of ditches/pipelines is planned to accommodate the railway line's route. The crossing of the company's ditch/pipeline at km 73+990 must be studied in detail during the construction design phase. Calculations indicate an unchanged flow at the outlet point (U33-14).

Created by
[Created by]
Case number
[Case number]

Document date
[Document date]

Confidentiality level
[Confidentiality level]

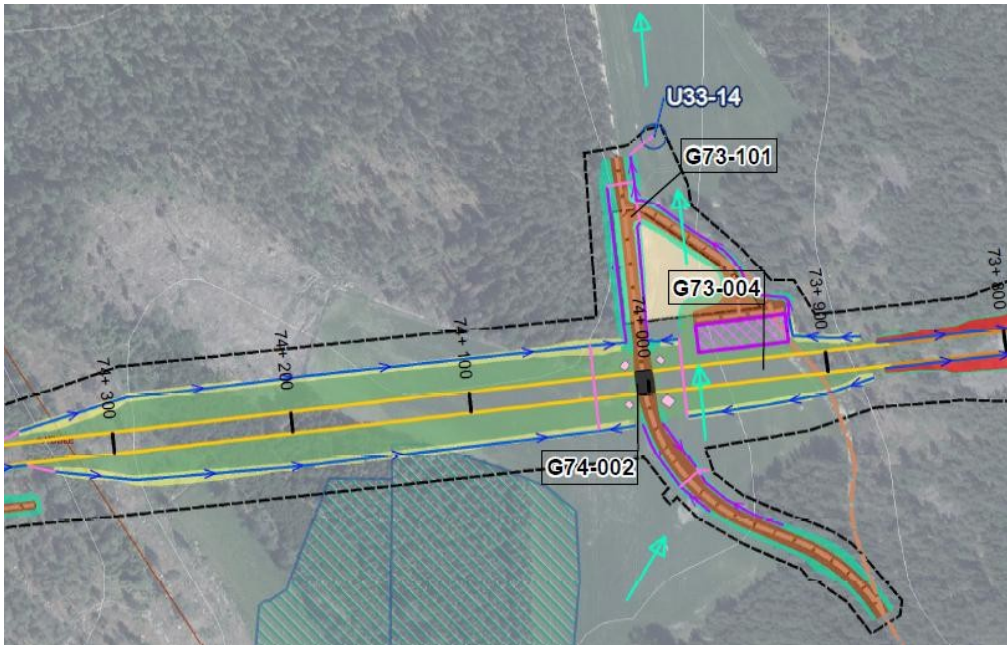

Figure C1.18. Discharge point to the Gävle land drainage company, Nybble TF.

Rogstad-Gammelstad-Sjukälla, Dammkärret, Norrtorp, Vik tf, 1922 (ID 93)

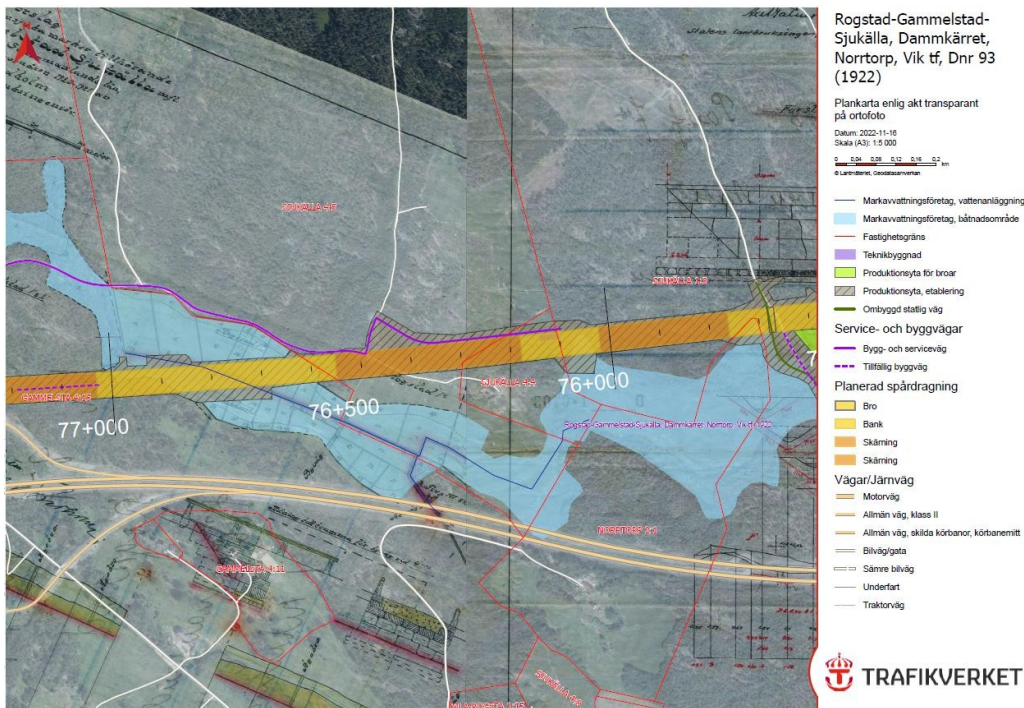

Figure C1.19. Overview map showing the land drainage project Rogstad-Gammelstad-Sjukälla, Dammkärret, Norrtorp, Vik tf, 1922 (ID 93).

Created by
 [Created by]
Case number
 [Case number]

Document date
 [Document date]

Confidentiality level
 [Confidentiality level]

The railway crosses a land drainage project between km 75+700–77+000. The scheme is a drainage scheme covering approximately 30 ha, located just north of the E4 and just east of road 216. Water from the scheme flows from the northern side of the E4, under the E4, then southwards to the Kilaån river and finally into Stadsfjärden. The scheme flows through both open ditches and underground pipes.

The drainage system is situated on arable land interspersed with woodland. The system connects to the Kilaån drainage system (ID 90) at the outlet towards the Kilaån.

The railway line's route will affect the drainage system at three locations. The first is furthest to the east at km 75+700, where retained water from the railway line is channelled into the system and then flows southwards through the system's pipes. The second location is at approximately km 76+050, where the railway line's retained drainage is channelled southwards and discharged into Lake Målarsjön via an erosion-proof outlet. The third area affected is at approximately km 76+750, where the company's main ditch is cut off. This ditch is planned to be rerouted and laid in a culvert beneath the railway line. The ditch will then be channelled, via a retention ditch, to an existing ditch located south of the railway line. Water from the railway line will be channelled and discharged into the existing ditch. Calculations indicate an increased flow of approximately 5% at discharge point U33-20.

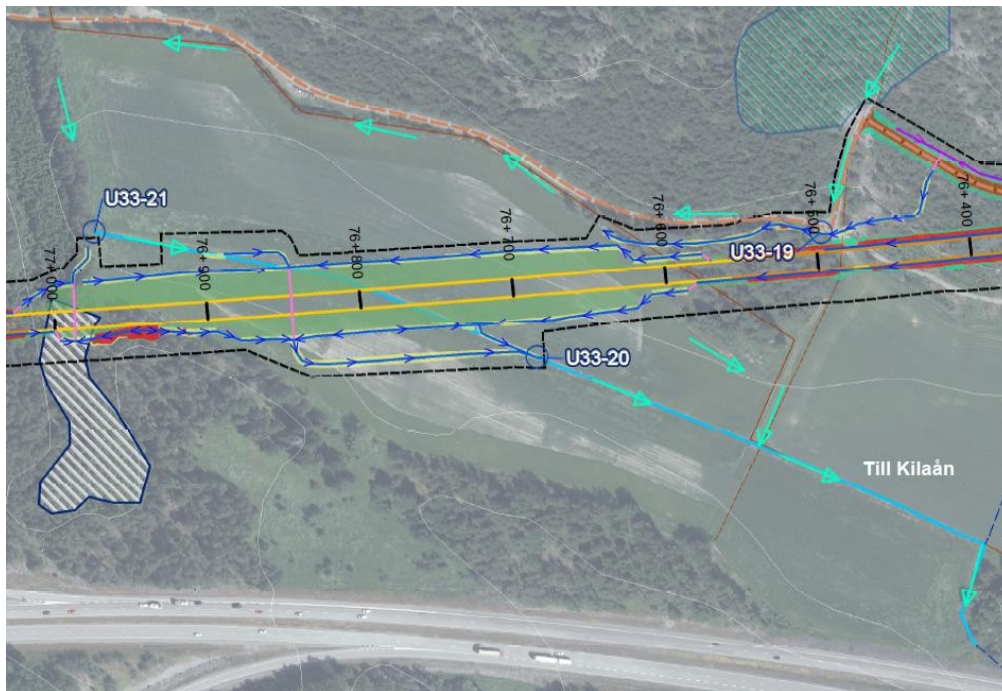

Figure C1.20. Discharge points for the Rogstad-Gammelstad-Sjukälla, Dammkärret, Norrtorp, Vik TF land drainage project.

Created by
 [Created by]
 Case number
 [Case number]

Document date
 [Document date]

Confidentiality level
 [Confidentiality level]

Gammelstad-Humlekärr-Sörby TF, 1928 ID 157

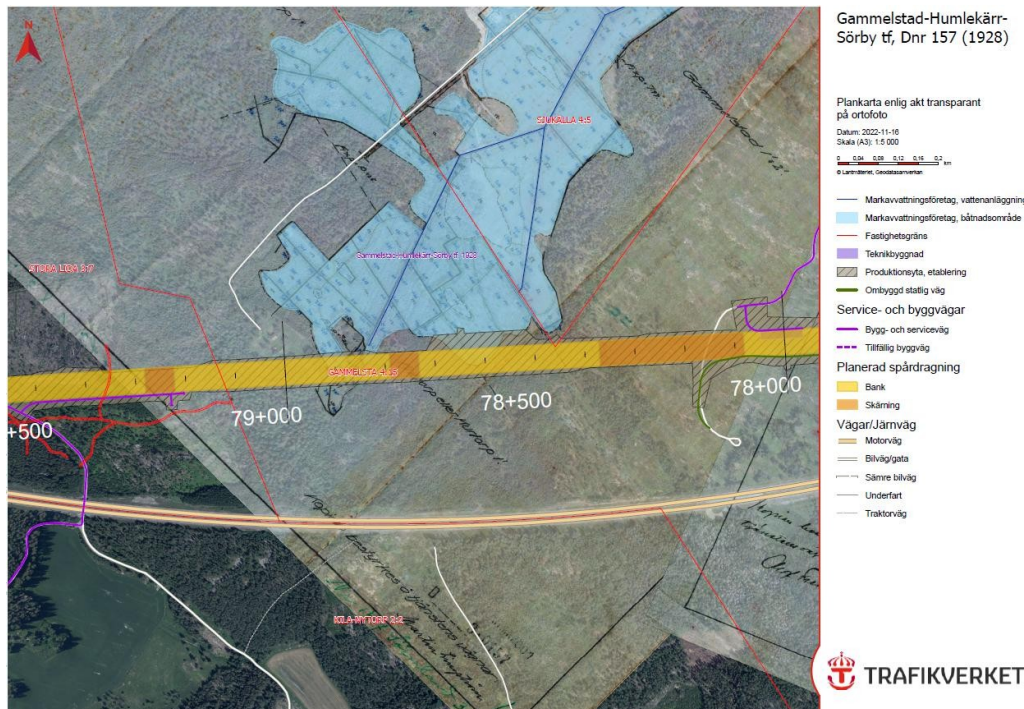

Figure C1.20. Overview map showing the Gammelstad-Humlekärr-Sörby TF land drainage scheme.

The railway crosses a land drainage project between km 78+450 and km 79+000. The project is situated north of the E4 and west of road 216, covering an area of approximately 154 hectares. Water from the scheme flows from the north side of the E4, under the E4, and continues south to the Kilaån river and out into Stadsfjärden. The drainage system runs through both open ditches and underground pipes. This land drainage system is also situated on arable land interspersed with woodland. Where this system's outlet connects to the Kilaån river, it is linked to the land drainage system with ID 90, just as the land drainage system with ID 93 is linked to the land drainage system with ID 90.

At the southern edge of the drainage system, the system will be affected by drainage from the railway line, as it is planned to receive delayed water from five outlets from the railway line as follows:

1. Water from both the northern and southern sides of the railway line is channelled into its ditches and on to a culvert at km 78+450, where it is then channelled northwards to the existing drainage company, U33-26.
2. At km 78+550, a retention ditch from the railway drainage system is connected.
3. At km 78+650, a retention ditch from the railway drainage system, U33-27, is connected.
4. At km 78+900, the railway's delayed water is connected to an existing ditch within the company, U33-28.
5. At km 79+150, a culvert is planned to cross the track, which will carry the track's delayed water from the southern side of the track towards the north and, together with the track's northern retention ditch, lead the delayed water into the drainage system, U33-29.

Created by
[Created by]
Case number
[Case number]

Document date
[Document date]

Confidentiality level
[Confidentiality level]

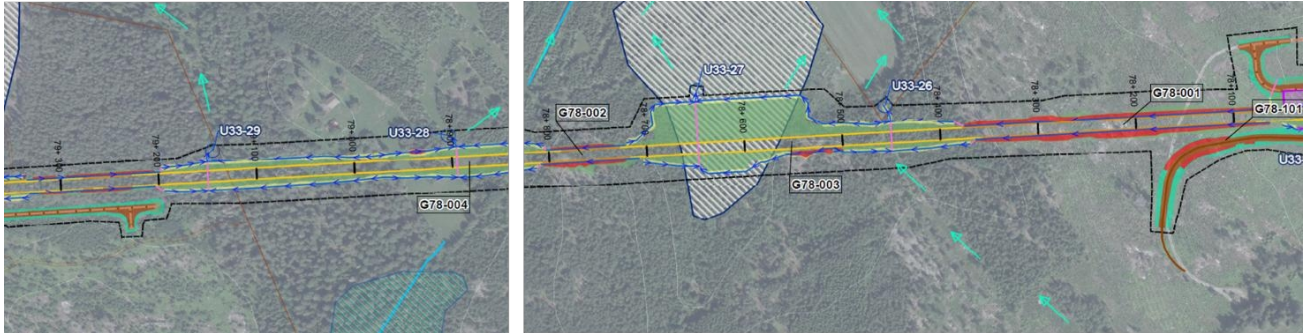

Figure C1.21. Discharge points to the Gammelstad-Humlekärr-Sörby TF land drainage scheme, 1928 ID 157

Function

The function, water-carrying capacity and drainage capability of the land drainage schemes must be maintained during and after the completion of the works.

The existing drainage system Gävle, Nybble TF, 1923 ID 103 must be identified and located during the design phase in order to develop the necessary methods for its management.

C1. Existing land and environment / Survey data

Scope

See Chapter A. Technical solution/geodetic surveying

C1. Existing land and environment/ Natural environment

Scope

Natural values have been surveyed along the route within and partly outside a study corridor. The results of the natural value surveys are presented in documents, the full versions of which will be provided upon signing the contract.

The conditions are described in general terms below.

Within the contract area, the railway passes through around ten sites classified as having high natural value (class 2). These are scattered along the route, but with a concentration in the far west near Stavsjö and in the valleys surrounding the Kilaån-Vretaån Natura 2000 site and its tributaries. The sites consist mainly of rocky pine forests, swamp forests and marshland. The highest concentration of natural values is found at Stavsjö, where several large sites with open and forested marshes are affected by the construction.

In total, eight watercourses are crossed which, following an inventory, have been assessed as having nature value class 1–3.

Four are class 3, significant nature value; three are class 2, high nature value; and Vretaån (NH3-10517), which is also a Natura 2000 site, is class 1, highest nature value.

The surface water bodies affected on this section are Vretaån – Kråkvasken (SE651218-586472), Virån-Ålbergaån (SE651577-153919) and Gammelstabäcken (SE651509-154704).

Created by
[Created by]
Case number
[Case number]

Document date
[Document date]

Confidentiality level
[Confidentiality level]

Vretaån constitutes a Natura 2000 site where the watercourse and its relevant tributaries are subject to conditions in the permit decision for the Kilaån-Vretaån Natura 2000 site SE0220304. The Vretaån is also protected as a nature reserve. The railway crosses the Kilaån area of national interest at three watercourses: the Ålbergaån, the Vretaån and the outlet of the Sågkärret.

Other watercourses crossed along the route are largely minor watercourses and streams/ditches in agricultural and forest land.

The East Link also passes through a groundwater body (SE651446-153738) subject to environmental quality standards along the Vretaån valley.

Surveys carried out indicate the presence of trees and natural environments requiring protection from impact during the construction phase. Some survey and investigation work remains to be done to clarify the need for protection of natural environment values within and adjacent to the work area. Further measures are also required regarding the need for actions to enhance biodiversity, the survey and relocation of protected species, and the survey of buildings prior to demolition. Within the areas covered by the railway plan's land claims, this work is being carried out by the client as preparatory work. This work will result in clear guidelines on which environments are to be protected and how, guidelines regarding biotope protection, wildlife refuges, management of dead wood, restrictions and more.

The need for protection and biotope-enhancing measures may involve both work within and restrictions on possible measures inside and outside the boundaries of the work area.

Function

Before any work commences, the Contractor shall ensure that the Client's processes regarding permits, exemptions and the relocation of species have been completed.

It is the Contractor's responsibility to establish protective measures in the form of fencing, enclosures and marking, and to carry out habitat enhancement measures in accordance with the instructions provided by the Client. The Client will provide these instructions in good time so that the specified protection can be established well in advance of the commencement of the works.

The Contractor is also responsible for maintaining the functionality of this protection throughout the contract period and for removing the protection when the need for protection from the contract works ceases. The protection or its installation must not in itself pose a risk of damage to the object or environment to be protected.

Should damage, despite protective measures, occur to sites of natural value or environments covered by the protective measures, the damage must be described and documented, and a report submitted to the client.

Furthermore, the Contractor is obliged to carry out an inventory and investigation of new areas not covered by the railway plan's land claims, such as construction roads used by the Contractor.

The Contractor shall then carry out this work to the same standard and using the same methods as those applied by the Client in the preparatory works. The provisions set out above regarding the protection of designated objects and environments and biotope-enhancing measures shall also apply to these areas.

Created by
[Created by]
Case number
[Case number]

Document date
[Document date]

Confidentiality level
[Confidentiality level]

Activities in connection with construction must not affect natural heritage sites designated by the Client or sites identified by the Contractor in areas utilised outside the established railway plan.

Protection against damage to nature conservation sites or the natural environment, established in accordance with instructions provided by the Client, shall be of a type and scope such that protection can be ensured and maintained throughout the entire period during which the risk of damage from the construction works remains. Within sites worthy of protection, all vegetation and soil outside the boundaries of the work area shall be preserved in their entirety.

Inspection

A documented inspection of the status of the natural areas shall be carried out prior to the start of construction, once the Contractor has put in place the designated protective measures in accordance with the instructions. A follow-up inspection, which shall also cover all biotope-enhancing measures, shall be carried out after the protective measures have been removed and other measures have been completed. The inspection shall be carried out by an expert, who shall draw up a report on the status of the conservation values following the construction period, including an assessment of any damage and impact. The Contractor is responsible for ensuring that the relevant landowner is offered the opportunity to participate.

C1. Existing land and environment / Recreation and outdoor life

Scope

The railway corridor passes through a varied landscape, large parts of which can be considered to have value for recreation and outdoor life. Woodland areas are used for mushroom and berry picking, the streams in the valleys for fishing, and local walking areas for strolls. Local walking areas are found, for example, north and east of Stavsjö on the western part of the section.

The Sörmlandsleden is a 1,000-kilometre-long hiking trail that runs through large parts of Södermanland. The trail winds its way through various natural environments and crosses the corridor for the new railway line at several points along the entire length of the Ostlänken route. On the Skavsta–Stavsjö section, the trail crosses the corridor at Rosenberg, near Stavsjö.

Valingeskogen is a popular area for outdoor recreation, and the forest is also home to Lake Rinkebyjön, which has a municipal bathing area in its southern part.

The Näckrosleden is a cycle route that winds its way through large parts of the Sörmland countryside. From Nyköping, the route heads south-west before turning north along Eriksgatan, part of the Gamla vägen Stavsjö-Krokek route of national interest, and crosses the E4 and the railway line at Önskehem (km 84+200). The route crosses the E4 and the railway line again at Vretaån (km 86+020) and on a private road, known as the Nunnebanan, north of Stavsjö (km 87+795).

Created by
[Created by]
Case number
[Case number]

Document date
[Document date]

Confidentiality level
[Confidentiality level]

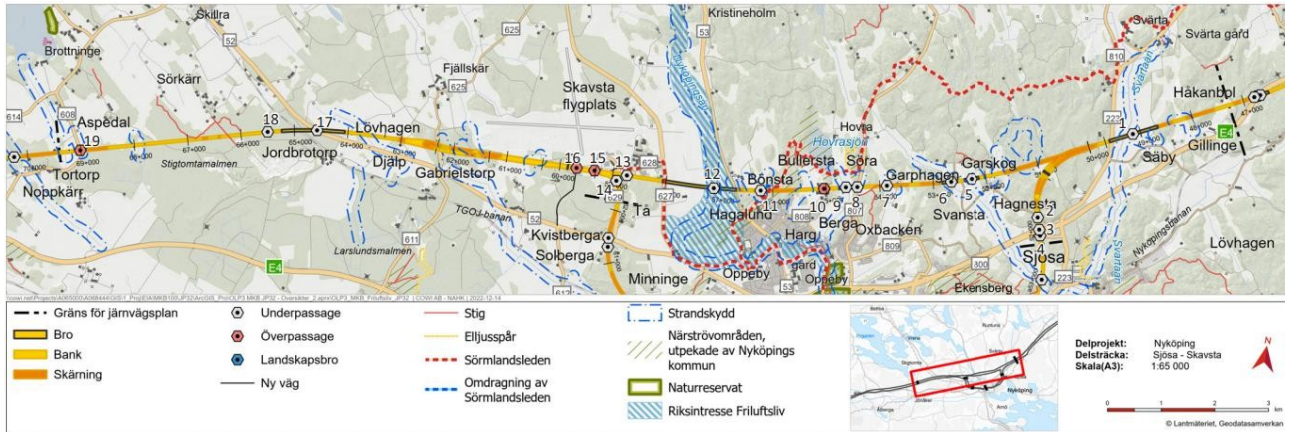

Figure C1.22. Destinations for recreation and outdoor activities within the Sjösa–Skavsta section.

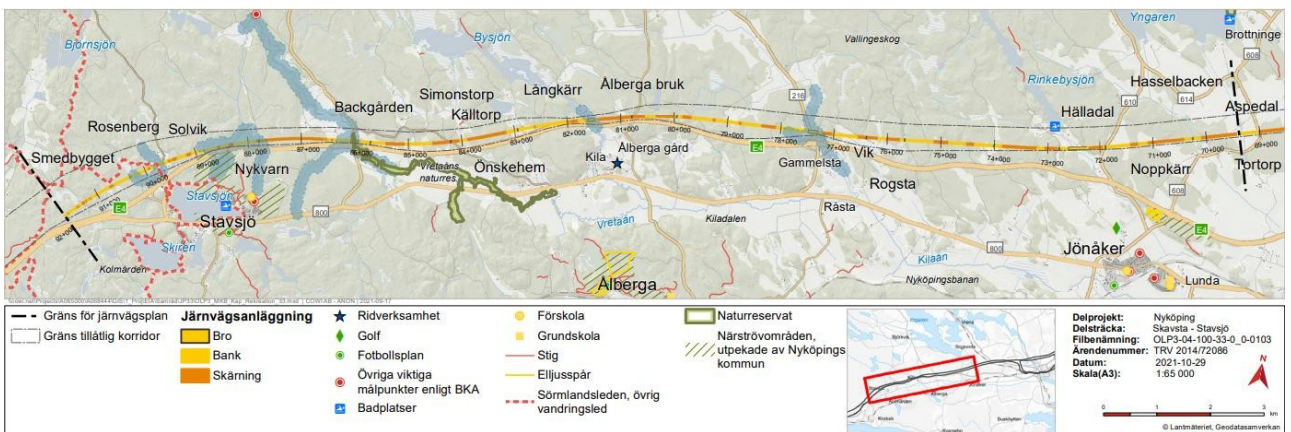

Figure C1.23. Destinations for recreation and outdoor activities within the Skavsta–Stavsjö section.

Function

During the construction period, it must be possible to engage in outdoor activities in the area; passage must always be possible during construction. At Rosenberg, km 89+750, the Sörmlandsleden trail must be kept open and accessible throughout the project. Information regarding access points must be displayed at the construction site and in the vicinity of the affected areas.

**C1. Existing land and environment / Vibration, air shock, noise
Scope Scope**

Documents relating to vibration, air shock and noise shall be submitted in full after the contract is signed. A general description of the conditions is provided below.

Created by
[Created by]
Case number
[Case number]

Document date
[Document date]

Confidentiality level
[Confidentiality level]

The seismic CPT investigations carried out are reported in the appendices to the Geotechnical Investigation Report (to be provided after the contract is signed).

There are properties and other objects in the area that may be adversely affected by vibration-generating activities. The scope is detailed in risk analyses (provided after the contract is signed).

Restrictions regarding noise are regulated in the AF.

Function

For vibration guidelines regarding vibration-generating activities, see “Memo: Risk Analysis of Vibration-Generating Activities During Construction”.

With regard to vibrations and air shocks, existing facilities and properties must not be adversely affected.

Technical solution

Before and after vibration-generating activities such as blasting, sheet piling, pile driving and compaction, inspections of buildings and facilities must be carried out in accordance with Swedish standard SS 460 48 60. Leak testing and inspection of fireplaces, flues and exhaust ducts must be carried out in accordance with Swedish standard SS 460 48 60. The objects and properties to be covered by the inspection are specified in “Memo: Risk analysis of vibration-generating activities during the construction period”.

As the risk analysis was produced during the system documentation phase, a review of the risk analysis must be carried out, and it must be supplemented and updated to the extent necessary.

The risk analysis must be supplemented with regard to buildings of cultural and historical value.

Monitoring

Methodology for monitoring and measuring vibration-generating activities is presented in “PM Risk Analysis of Vibration-Generating Activities During Construction”, which is provided after the contract is signed.

C1. Existing land and environment/Surface water

Scope

Documents referred to in this chapter will be provided after the contract has been signed. A general description of the conditions is provided below.

Within the Ålberga contract area, the railway crosses three surface water bodies. These surface water bodies are described in more detail in the EIA for the Skavsta-Stavsjö Railway Plan.

- Gammelstabäcken (SE651509-154704)
 - Gammelstabäcken has moderate ecological status due to eutrophication and physical impacts on the watercourse. Its chemical status does not meet the ‘good’ standard due to the substances mercury (Hg) and brominated diphenyl ethers (PDBE), for which national limits are exceeded everywhere. The railway crosses Gammelstabäcken at km 77+250–77+420 via a landscape bridge approximately 170 metres long.
- Virån-Ålbergaån (SE651577-153919)

Created by
[Created by]
Case number
[Case number]

Document date
[Document date]

Confidentiality level
[Confidentiality level]

- The Virån-Ålbergaån watercourse has moderate ecological status because the connectivity quality factor in the watercourse has been assessed as poor, due to migration barriers. The Virån-Railway crosses the Ålbergaån on a bridge between km 81+490 and 81+620.
- Vretaån – Kråkvasken (SE651218-586472)
 - Vretaån-Kråkvasken has moderate ecological status based on the quality factors fish, nutrients and connectivity, and does not achieve good chemical status due to the widespread exceedances of mercury and brominated diphenyl ethers. Within the contract area, the water body is crossed by a bridge at two points by the planned railway line, at km 86+020 and km 88+327.

The surface water bodies Yngaren (SE653034-154584) and Kilaån (SE651345-155397) are indirectly affected as they serve as receiving waters for drainage water from the railway line. Water bodies are subject to environmental quality standards (EQS).

Within the affected section, there are also a large number of aquatic sites of natural value affected by the facility, which, following an inventory, are assessed as having a natural value class of 1–3.

The Vretaån river forms part of the Kilaån-Vretaån Natura 2000 site (SE 0220304) and, like 10 crossings of tributaries to the Natura 2000 site, is subject to a permit with conditions.

The route also crosses a large number of smaller ditches, watercourses and wetlands that do not constitute designated water bodies. In total, there are over 260 water-related activities along the route, of which approximately 80 are surface water activities and the remainder relate to the abstraction of groundwater, many of which give rise to a need for the discharge of drainage water.

Work within water areas covered by the Contract is subject to a water activity permit. The permit is subject to conditions.

Function

Work in water

Existing water bodies must be protected against adverse impacts resulting from the project, and the works must not lead to a deterioration in environmental quality standards for the water bodies within the works area. The general requirements for protective measures when working in aquatic areas such as wetlands, watercourses, ditches and lakes are set out below.

Damage prevention and protective measures taken must be effective in all weather conditions.

For individual sites or discharge points, the requirement for protective measures may be relaxed or waived entirely if the Contractor can demonstrate, through its own investigation, that the measure is clearly unnecessary or that no damage or unacceptable disturbance can occur in the receiving water body. The Contractor's investigation and proposed working methods must be approved by the Client.

Dimensioning and design

In the case of works in watercourses and ditches, the structure shall be dimensioned so that neither damming nor barriers to the migration of aquatic organisms arise.

Created by
[Created by]
Case number
[Case number]

Document date
[Document date]

Confidentiality level
[Confidentiality level]

When diverting watercourses, the new watercourse must, as far as possible, replicate the conditions found in the existing watercourse. This requirement applies to both vegetation on slopes and within the watercourse, and the watercourse must have an equivalent bottom substrate.

Work in dry conditions

Work in drained ditches and ditches with very low flows (less than 1 litre per second) does not need to be carried out in dry conditions.

Work in ditches and watercourses with higher flows – greater than 1 litre per second – must be carried out in dry conditions.

Drainage when replacing organic soils/material

When replacing organic soils in wetland areas, drainage of the excavated soil must take place adjacent to the wetland area so that runoff returns to the wetland area.

Concrete casting in water areas

Concrete casting within water areas must be carried out in dry conditions within sheet piling.

Turbidity control measures

When carrying out works in ponds, lakes, ditches and watercourses, and when discharging drainage water, measures to limit turbidity must be taken.

Turbidity control measures need not be carried out when working in drained ditches and ditches with very low flows; less than 1 litre per second.

Turbidity barriers may only be removed once turbidity has ceased. Turbidity barriers shall be used whilst turbidity-causing work is being carried out and thereafter, until the turbidity is of the same order of magnitude as in the surrounding water.

When using turbidity barriers in larger watercourses containing fish, one side of the watercourse must be cordoned off at a time so that fish can pass past the turbidity barrier.

Work affecting the riparian zone and riverbeds

Sedimentation on sensitive riverbeds (trout spawning grounds) must be avoided. When carrying out work in and around watercourses that affects the riverbed, the riverbed and vegetation along the banks must be restored once the work is complete.

Discharge of surface water and drainage water

In addition to the requirements for surface water described above, the following requirements apply:

- Direct discharge of site drainage and dewatering water into watercourses or lakes must be avoided. Overflow and infiltration must be applied where possible within the work area, taking into account soil type and available surface area. In each individual case where the Contractor assesses that direct discharge into a lake or watercourse cannot be avoided, the reasons must be justified and planned protective measures reported at least two weeks before discharge is to commence. Discharge must not commence until the client has given their approval.
- Where necessary, treatment of surface water and drainage water shall be carried out before the water is discharged into the receiving water body. The treatment shall be carried out within the work area and using appropriate treatment stages such as sedimentation, oil separation and pH adjustment.

Created by
[Created by]
Case number
[Case number]

Document date
[Document date]

Confidentiality level
[Confidentiality level]

- Discharged drainage water must have a pH value between 6 and 9. Where necessary, pH adjustment must be carried out.

Monitoring

The Contractor shall monitor any impact on surface water. Monitoring need not be carried out in watercourses with no flow, where the flow is less than 1 litre per second, or where the Contractor has demonstrated through investigation that protective measures may be omitted.

Discharge points for drainage water are specified in FB7.

When discharging drainage water and stormwater from spoil tips, monitoring of the water and the receiving water body shall be carried out based on the duration of the respective discharge. For this purpose, discharges are categorised into the following three categories:

- Short-term discharges; duration ≤ 14 days.
- Medium-term discharges; duration of 15 days – 3 months.
- Long-term discharges; duration > 3 months.

All checks must be documented in tabular summaries, which must be kept available and provided to the client on request. For checks carried out using digital field instruments, the type of measuring instrument must be documented at each measurement occasion, and efforts must be made to use the same type of instrument on all measurement occasions. It must be ensured that all measuring instruments used are correctly calibrated in accordance with the manufacturer's instructions and that they are used in accordance with the manufacturer's instructions. For analyses, an accredited laboratory and standardised analysis must be used.

Monitoring of short-term emissions

The checks to be carried out in the event of short-term emissions are:

- pH
- visual inspection for oil

pH checks in the water must be carried out before discharges commence into a sump or equivalent point before the water is released from the work area. Checks must be carried out using digital field instruments, and the water must not be discharged if the pH exceeds 9 or falls below 6. With regard to discharges into the Natura 2000 area Kilaån – Vretaån and all its tributaries, the pH must not be lower than 6.5 or higher than 7.5.

Visual checks for the presence of oil in the water must be carried out daily and conducted in the water in the excavation pit or equivalent before the water leaves the work area.

Checks for medium-term discharges

Checks to be carried out for medium-term discharges are:

- pH
- visual inspection for oil
- turbidity in the receiving water

pH checks and visual checks for the presence of oil in the effluent must be carried out daily at a point before the water is discharged from the work area. pH checks must be carried out using digital field instruments, and the water must not be discharged if the pH exceeds 9 or falls below 6. With regard to discharges into the Natura

Created by
[Created by]
Case number
[Case number]

Document date
[Document date]

Confidentiality level
[Confidentiality level]

2000 area Kilaån – Vretaån and all its tributaries, the pH must not be lower than 6.5 or higher than 7.5.

Turbidity checks must be carried out daily, partly by measurement using digital field instruments, and partly by visual inspection of the length of the turbidity plume.

When measuring with digital field instruments, turbidity at a monitoring point must be referenced against conditions at an unaffected reference point. For discharges into watercourses, the reference point shall be located approximately 20 metres upstream of the discharge point and the monitoring point approximately 50 metres downstream of the discharge point, or, where applicable, approximately 50 metres downstream of turbidity barriers intended for the discharge in question. In the case of discharges into standing waters such as lakes, the reference point shall be located 250 metres from the discharge point and the monitoring point shall be located 50 metres from the discharge point, or where applicable 50 metres from turbidity barriers intended for the discharge in question. Where several different works and/or discharges are carried out simultaneously in neighbouring parts of a water body, the monitoring shall be carried out for the combined impact.

The monitoring shall be documented in tabular form, showing the following values: turbidity at the reference point (FNU), turbidity at the monitoring point (FNU), the difference between the monitoring point and the reference point (FNU), and the difference between the monitoring point and the reference point (FNU) as a rolling average over 14 days.

Visual inspection of the extent of turbidity shall be carried out by observing the length of the turbidity plume caused by the current works or discharge. A turbidity plume refers to the visible spread of suspended material dispersing in the water body from the current discharge. The length of the turbidity plume shall be measured from the location of the current works or discharge into the water until it is no longer visible. In cases where several different works and/or discharges are carried out simultaneously in neighbouring parts of a water body, the assessment must be made for the combined impact, i.e. measurements must be taken from the works or discharge taking place furthest downstream in the watercourse. The length of the turbidity plume shall be categorised into one of the four classes below and recorded in the same log as the turbidity measurements carried out.

- < 10 m
- 10–25 m
- 25–50 m
- > 50 m

Monitoring of long-term emissions

Monitoring of long-term discharges is carried out to the same extent and in the same manner as monitoring of medium-term discharges, see above.

If results from the Swedish Transport Administration's own monitoring indicate elevated levels of metals in the receiving water body, the contractor shall carry out supplementary sampling and analysis of the contents of the drainage water in order to investigate the causes of the elevated levels and, if necessary, take appropriate measures within the scope of the contract.

Guideline values and measures

pH

Created by
[Created by]
Case number
[Case number]

Document date
[Document date]

Confidentiality level
[Confidentiality level]

Discharge of drainage water and stormwater from production areas is permitted only if the pH of the effluent is within the range 6–9. If a deviating pH is detected, discharge must be stopped immediately and measures taken, if necessary, to adjust the pH. Discharge must not resume until the pH value has stabilised within the approved range.

Visual inspection for the presence of oil

If the presence of oil is detected in the effluent or the receiving water body during visual inspections, the work area and working methods must be reviewed immediately to identify the source of the contamination. Action must be taken at the source and, where necessary, supplemented with protective measures such as the containment of spills on and in the ground and/or water. The client must be informed of the contamination and of the measures planned and taken.

Turbidity in the receiving water body

In the event of a discharge lasting longer than 14 days, turbidity at the monitoring point must not exceed turbidity at the reference point by more than 15 FNU in sensitive receiving waters and 35 FNU in less sensitive receiving waters, measured as a rolling average over 14 days. The client must be informed immediately if measured values exceeding 15 or 35 FNU are recorded, and if the applicable limit value for the 14-day average is exceeded. In the event of the applicable limit value being exceeded, the client must also be provided with an initial analysis of the cause of the exceedance. Furthermore, the work area and working methods shall be reviewed in order to identify the cause of the current exceedance. Depending on the cause, appropriate measures shall then be taken. Measures may relate, for example, to working methods, the layout of the work area, protective measures or supplementary treatment of effluent. An action plan for measures shall be drawn up by the contractor and approved by the client.

C1. Existing land and environment/Surface water/N2000 area Kilaån-Vretaån with tributaries

Scope

Kilaån-Vretaån constitutes a Natura 2000 area (SE 0220304) and the crossing of the Vretaån, as well as a further 10 crossings of tributaries to the Natura 2000 area, are subject to a permit attached to conditions.

The permit decision was issued by the County Administrative Board on 14 October 2014. The decision was appealed by the Swedish Transport Administration, whereupon the Land and Environment Court amended conditions 2, 10, 14, 21 and 26 in a judgment dated 26 October 2015, case number MMD 6448-14. Following a request for a review of the conditions, the County Administrative Board subsequently decided, in a decision dated 28 September 2021, to amend the wording of condition 8 in the permit decision.

Following a request from the Swedish Transport Administration in connection with an environmental assessment of water operations along the Skavsta–Stavsjö section, the Land and Environment Court, in a decision dated 20 May 2025, amended conditions 31, 34, 40, 48 and 51.

Function

The contractor shall comply with the site-specific requirements set out in the table below when working within the Kilaån-Vretaån Natura 2000 site (SE 0220304) and its named tributaries. Changes to the requirements may occur as a result of the permit review and following consultation with the supervisory authority. All contact with supervisory authorities shall be handled by the client.

Created by
[Created by]
Case number
[Case number]

Document date
[Document date]

Confidentiality level
[Confidentiality level]

Table. Site-specific requirements for work that affects the Kilaån-Vretaån Natura 2000 site, including its tributaries.

General requirements
1. The construction and operation of the East Link within the Natura 2000 site Kilaån–Vretaån (SE 0220304) in the municipality of Nyköping, including tributaries, shall be carried out primarily in accordance with the application and the documents attached thereto, unless otherwise specified in the conditions below.
General requirements
2. No encroachment or construction, either in the watercourse or within the ravine surrounding the watercourse, may take place within the Kilaån – Vretaån Natura 2000 site. However, the Swedish Transport Administration is entitled to carry out necessary felling and pruning of trees on the site. Felling shall be carried out in consultation with the County Administrative Board.
3. Bridge piers must not be placed within the Kilaån – Vretaån Natura 2000 site, and work to erect the bridge must be carried out from both sides of the ravine’s edges.
4. The construction of the bridge must not alter the groundwater flows to the Kilaån–Vretaån Natura 2000 site in such a way that the inflow or the hydrology of the watercourse is adversely affected.
5. No movement of work vehicles or construction of access roads may take place either within the water area or within the ravine surrounding the Vretaån watercourse, in the Kilaån – Vretaån Natura 2000 site.
6. Parking and service areas for vehicles and machinery must be arranged in such a way that leaks and spills of fuel or other chemicals cannot contaminate the Kilaån – Vretaån Natura 2000 site or any of its tributaries.
7. Chemical pesticides must not be used within the Kilaån – Vretaån Natura 2000 site, within the ravine surrounding the Vretaån, or so close that there is a risk of them spreading to the Natura 2000 site or to any of its tributaries.
8. During the construction phase, a balancing reservoir shall be constructed to divert drainage water from work areas along the Vretaån.
9. Contingency measures in the form of oil booms and absorbent materials must be available to the contractor at the worksite.
10. Temporary storage of materials and spoil must not be located within the Kilaån–Vretaån Natura 2000 site. Temporary storage of materials and spoil that risks damaging the natural values that the Natura 2000 site is intended to protect must not be located within 200 metres of the Kilaån – Vretaån Natura 2000 site or any of its tributaries.
11. Concrete casting must not take place in, or in such a way that water with a pH value higher than 7.5 can reach, the Kilaån – Vretaån Natura 2000 site or any of its tributaries.
12. No barriers to the migration of fish or otters may be created within the Kilaån – Vretaån Natura 2000 site or within any of its tributaries.
13. At the railway’s crossings with the tributaries, wildlife fencing must be erected and passageways for otters must be provided.
14. A monitoring programme for the construction phase must be in place for the project and adhered to. The programme must, among other things, specify how the project’s direct and indirect impacts on the Natura 2000



Created by
[Created by]
Case number
[Case number]

Document date
[Document date]

Confidentiality level
[Confidentiality level]

site Kilaån – Vretaån and on all its tributaries shall be monitored with regard to measurement method, measurement frequency and evaluation method. The programme shall also include monitoring of groundwater levels in the surrounding area, storage sites, safe handling of transport and emergency preparedness. A first draft of the monitoring programme must be submitted to the supervisory authority no later than 2 years before the start of construction. Measurements must commence no later than 1 year before the start of construction.

Please note that this monitoring programme is to be drawn up by the client.

15. A proposed monitoring programme for the impact on watercourses of the operation of the East Link within the Kilaån–Vretaån Natura 2000 site must be drawn up. The programme must also include monitoring of the impact on species covered by the Species Protection Ordinance and Natura 2000 habitat types. The programme must be submitted to the supervisory authority no later than two years before the railway enters service in the Natura 2000 area.

Please note that this monitoring programme is to be drawn up by the client.

Special requirements

The coordinates are specified according to the RT 90 2.5 V 0:-15 system

The outlet of Lake Rinkeby (Björnbäcken) (M1, coordinates 6515980, E597949) ID G72-001

16. A bridge is to be constructed over the outlet of Lake Rinkeby.

17. Bridges and culverts under the access road and railway must be positioned so that the natural width of Rinkebysjön is not affected.

18. No work or movement of work vehicles may take place in or adjacent to the outlet of Lake Rinkeby in such a way as to damage its shores.

19. Turbidity control measures must be put in place for works that pose a risk of turbidity in the watercourse.

Stream N Gammelsta (M4, coordinates 6515407, 1546726) ID G73-003

20. A bridge shall be constructed over the stream north of Gammelsta.

21. Bridge piers must not be constructed within the ravine formation.

22. Bridges and culverts beneath the access road and railway must be positioned so as not to affect the stream's natural width.

23. No work or movement of work vehicles may take place in or adjacent to the stream north of Gammelsta in such a way as to damage its banks.

24. Turbidity control measures must be put in place for works that pose a risk of turbidity in the watercourse.

Ålbergaån (M10, coordinates 6514792, 1542628, 6514811, 1542701) ID G81-002

25. A bridge shall be constructed over the Ålbergaån.

26. Bridge piers must not be constructed within the ravine formation

27. Bridges and culverts beneath the access road and railway must be positioned so that the natural width of the stream is not affected.

Created by
[Created by]
Case number
[Case number]

Document date
[Document date]

Confidentiality level
[Confidentiality level]

28. No work or movement of work vehicles may take place in or adjacent to the Ålbergaån in such a way as to damage its banks.
29. Turbidity-causing works must not be carried out between 1 October and 15 June. At other times, turbidity control measures must be put in place for works that pose a risk of turbidity in the watercourse.
Field ditch S Källtorp (M13, coordinates 6514338, 1541331) ID Y82-012 and 013
30. Bridges and culverts beneath service roads and railway lines must be positioned so that the natural width of the field ditch is not affected.
31. No work or movement of work vehicles may take place in or adjacent to the field ditch in such a way as to damage its banks, except for work necessary to carry out authorised water activities.
32. Turbidity control measures must be put in place for works that pose a risk of turbidity in the watercourse.
Field ditch S Simonstorp (M14, coordinates 6513986, 1540430) ID 83-003
33. Bridges and culverts under access roads and railway lines must be positioned so that the natural width of the field ditch is not affected.
34. No work or movement of work vehicles may take place in or adjacent to the field ditch in such a way as to damage its banks, except for work necessary to carry out authorised water activities.
35. Turbidity control measures must be put in place for works that pose a risk of turbidity in the watercourse.
Field ditch/forest stream V Lilla Källa (M15, coordinates 6513735, 1539421) ID Y84-005 and 006
36. Bridges and culverts under access roads and railway lines must be positioned so that the natural width of the field ditch/forest stream is not affected.
37. No work or movement of work vehicles may take place in or adjacent to the field ditch/forest stream in such a way as to damage its banks, except for work necessary to carry out authorised water activities.
38. Turbidity control measures must be put in place for works that pose a risk of turbidity in the watercourse.
Forest stream NO Sågkärret (M17, coordinates 6513357, 1536484, 6513287, 1536605) ID Y87-001, 002, 005
39. Bridges and culverts under access roads and railway lines must be positioned so that the natural width of the forest stream is not affected.
40. No work or movement of work vehicles may take place in or adjacent to the forest stream north-east of Sågkärret in such a way as to damage its banks, except for work necessary to carry out authorised water activities.
41. Turbidity control measures must be put in place for works that pose a risk of turbidity in the watercourse.
The outlet of Sågkärret (M18, coordinates 6513298, 1536211, 6513304, 1536233) ID G88-002
42. A bridge shall be constructed across the watercourse at the outlet of Sågkärret
43. Bridge piers must not be constructed in the watercourse or its riparian zone.
44. Bridges and culverts beneath service roads and railway lines must be positioned so that the natural width at the outlet of Sågkärret is not affected.

Created by
[Created by]
Case number
[Case number]

Document date
[Document date]

Confidentiality level
[Confidentiality level]

45. No work or movement of work vehicles may take place in or adjacent to the outlet of Sägkärret in such a way as to damage its banks.
46. Work causing turbidity must not be carried out between 1 October and 15 June. At other times, measures to prevent turbidity must be put in place for work that carries a risk of causing turbidity in the watercourse.
Forest ditch NV Sägkärret (M19, coordinates 6513118, 1536102) ID Y88-002 and 003
47. Bridges and culverts under access roads and railway lines must be positioned so that the natural width of the forest ditch is not affected.
48. No work or movement of work vehicles may take place in or adjacent to the forest ditch in such a way as to damage its banks, except for work necessary to carry out authorised water operations.
49. Turbidity control measures must be put in place for works that pose a risk of turbidity in the watercourse.
Stavsjö Stream NW (M20, coordinates 6512520, 1534891) ID Y89-001, 002 and 003
50. Bridges and culverts beneath access roads and railway lines must be positioned so that the natural width of the stream is not affected.
51. No work or movement of work vehicles may take place in or adjacent to the stream in such a way as to damage its banks, except for work necessary to carry out authorised water activities.
52. Turbidity control measures must be put in place for works that pose a risk of turbidity in the watercourse.

In addition to the watercourses listed in the table above, the following watercourses are also subject to the general requirements.

Other watercourses/ditches covered by general conditions 1–15
M2 Ditch at Målarsjön, Water activity ID Y75-005
M3 Watercourse Vik, Water activity ID Y76-005, Y76-006
M6 Field ditch at Källbol, water activity ID Y78-006
M8 Forest ditch V Höglunda, water activity ID Y79-004
M11 Forest ditch west of Ålberga bruk, Water activity ID Y82-004, Y82-005
M12 Forest ditch NE of Långkärr, Water activity ID Y82-007
M23 Watercourse Vinbärskärret, ID water activity Y90-005

C1. Existing land and environment/Surface water/Lake Stavsjön

Function

Drainage water from areas used for the storage of rock material or which, for other reasons, contain or may contain elevated nitrogen levels must not be discharged into Lake Stavsjön.

Created by
[Created by]
Case number
[Case number]

Document date
[Document date]

Confidentiality level
[Confidentiality level]

C2. Existing structure/Building

Scope

All remaining buildings, including foundations within the permanent land claim, are to be demolished. Consultation with utility owners must take place prior to demolition. A preliminary assessment indicates that this involves 20–25 buildings.

An environmental survey of the buildings prior to demolition will be carried out by the client

C2. Existing structure/Drainage system

Scope

All arable land affected is likely to be drained. Field drainage pipes will therefore be cut when the railway is built over arable land. Information on the design of the field drainage systems is lacking.

Function

All affected field drainage systems must retain their functions during the construction and operational phases.

Existing drainage systems affected by the design and construction of the railway line must be adapted to the conditions that will prevail during construction and after completion of the project.

Technical solution

Restoration of agricultural drainage affected by the works must comply with *the Guidelines for the Restoration of Agricultural Drainage (Swedish Board of Agriculture, 2011)*

C2. Existing structure/ Boundary marking

Scope

Boundary markings for properties within the work area.

Function

Existing boundary markings within the project area must be surveyed and protected from damage throughout the project period. If markings are at risk of being damaged or destroyed, the land registration authority must be notified.

Damaged or destroyed boundary points must be replaced. Marking must be carried out by the land registration authority and paid for by the client.

C2. Existing structure/Railway infrastructure

Scope

The railway is entirely new and there are no connections or adaptations to existing tracks. On the route, *the* existing single-track *TGOJ line* is crossed at km 64+590, where the East Link crosses via a bridge.

The TGOJ line's overhead contact line will be lowered by the Swedish Transport Administration before construction begins.

Created by
[Created by]
Case number
[Case number]

Document date
[Document date]

Confidentiality level
[Confidentiality level]

C2. Existing structure / Frame grid

Function

See Chapter A. Technical solution/geodetic surveying techniques

C2. Existing structure/Cables

Scope

Unknown cables and unforeseen situations may arise with regard to existing cables. A number of unknown cables may be present. Cables that are in operation must remain in operation throughout the contract period or be temporarily rerouted in consultation with the respective cable owners.

The utility owners listed below have both overhead and underground cables, as well as associated equipment such as, among other things, manholes, junction boxes, poles, valves, etc. in the area, which will come into conflict with the works.

A list of approximate crossing points is included in the documentation provided during the system design phase and will be shared after the contract is signed.

- Vattenfall Regional Network Electricity Network, High Voltage
- Vattenfall Electricity Distribution Electricity network, low and medium voltage
- Skanova Telecom/Fibre
- Gästabudstaden Opto
- IP Only AB Opto
- Huawei Opto

The instructions of the respective cable owners must be obtained and followed during design and execution.

Prior to the start of the contract, the contractor must obtain up-to-date utility information from Ledningskollen.

The utility owners' records of completed works shall be regarded as existing conditions for this contract.

Electrical cables consist of Vattenfall Eldistribution's low- and medium-voltage networks, including both overhead and underground cables, and Vattenfall Regionnät's high-voltage network, comprising overhead cables

Note that even a crossed-out, decommissioned cable, such as an electrical cable, may still be live. Telecommunications cables consist of underground fibre-optic and copper cables, as well as overhead cables.

Before any excavation work may commence, the contractor must place their own order with Ledningskollen and contact the respective cable owners, request the marking out of the locations of existing cables and lines, and obtain instructions regarding the necessary protective measures to be taken during the execution of the works.

Where necessary, any unrecorded cables discovered during the contract period must be planned and rerouted in consultation with the client and the cable owners.

The functionality of existing cables must be ensured throughout the contract period.

Existing cables must be protected so that they can withstand increased loads from traffic and construction traffic, etc. The choice of method for protecting cables must be made in consultation with the cable owner.

For overhead cables, protection in the form of gantries installed at a clear height must be erected. The choice of gantry must be made in consultation with the utility owner.

If a cable is encountered that is not marked on the cable plan, the cable owner and the client must be contacted immediately.

Created by
[Created by]
Case number
[Case number]

Document date
[Document date]

Confidentiality level
[Confidentiality level]

Inspection

The contractor shall design and carry out inspections in such a manner and to such an extent that the respective cable owners' requirements are met.

The contractor shall draw up an inspection programme with associated inspection plans for design and construction, as well as for materials and goods used.

Where inspection requirements are specified, these shall be incorporated into the inspection programme and associated inspection plans. If inspection requirements are not specified, the contractor shall specify the inspection method based on the utility owner's and client's requirements or the contractor's chosen technical solution.

Inspection of pipes and cables shall be carried out in accordance with the pipe and cable owner's requirements and documented in the inspection programme prior to the start of construction.

Technical solution

Underground cables/pipes that will cross tracks must be laid in protective conduits.

The distance from all external existing utility poles outside the railway premises to the track must be at least 20 metres.

C2. Existing structures/water and sewerage network

Scope

All cables and equipment within the work area must be inventoried, surveyed and protected against damage throughout the project period by the contractor.

Demolition, rerouting and protection of cables must be carried out for all cables and equipment. Unknown cables and equipment subject to confidentiality may be present within the contract area.

The contractor shall coordinate their work with the owners of the pipes and the client and integrate existing structures into the design and construction.

Function

Existing cables and installations within and adjacent to the contract area shall be protected against increased loads and damage throughout the contract period.

The functionality of existing cables and installations within and adjacent to the contract area must be ensured throughout the contract period and must be accessible to the respective cable owners.

Any service interruptions and measures to maintain functionality must be coordinated with the cable owners and the client in good time prior to implementation.

Inspection

The contractor shall draw up an inspection programme with associated inspection plans for design and construction, as well as for materials and goods used.

Testing and inspection programmes shall be approved by the utility owners and the client in good time prior to design and construction.

C2. Existing structure/roadworks

Scope

Created by
[Created by]
Case number
[Case number]

Document date
[Document date]

Confidentiality level
[Confidentiality level]

The scope is shown in the illustrative drawings.

Function

Demolition of existing road infrastructure shall be carried out to the extent necessary to enable the construction of new facilities.

All parts of the road infrastructure shall be demolished along the sections of state roads that are removed as part of the project.

The functionality of existing road barriers affected shall be maintained.

Areas where the road infrastructure is demolished shall be restored to bare ground with a vegetation bed >0.3 m.

Existing road infrastructure to be retained must not be adversely affected. Settlement requirements must be adjusted in relation to documented settlements for the road infrastructure, i.e. account must be taken of settlements that have already occurred.

Monitoring

Prior to earthworks, excavation and foundation work, forecasts, control measurements and monitoring of environmental impact must be carried out.

Inspections must be described in an inspection programme for structures at risk of damage from ground movements, vibrations, groundwater lowering, etc.

The monitoring programmes must include alarm and stop values with associated measures, tailored to the respective structure.

The control programme drawn up must be approved by the client before physical work can commence.

C2. Existing structure / Roads

Scope

Group/ Location		Layer	Surface
Road	Bridge/location		
Road 608	69+000	40 mm Bound base course, 80 mm unbound base course, 420 mm Reinforcement course	40 mm bituminous wearing course
Road 537	80+790	40 mm bound base course, 80 mm unbound base course, 200 mm reinforcement course	40 mm bituminous wearing course
Road 534	86+050	40 mm bound base course, 80 mm unbound base course, 420 mm reinforcement course, 150 mm protective course	40 mm bituminous wearing course
Private roads		100 mm base course, 550 mm reinforcement course	50 mm Gravel wearing course

Technical solution

Created by
[Created by]
Case number
[Case number]

Document date
[Document date]

Confidentiality level
[Confidentiality level]

Existing roads shall be excavated in respect of the sections specified in Table (D).1 Binder courses and base courses shall be demolished separately.

Demolition and handling of bituminous layers shall be carried out in accordance with the provisions of VV Publication 2004:91 (Handbook for the recycling of asphalt).

Demolished bituminous pavement materials shall be reused on site in accordance with the requirements of VV Publication 2004:91 (Handbook for the Recycling of Asphalt).

Created by
[Created by]
Case number
[Case number]

Document date
[Document date]

Confidentiality level
[Confidentiality level]

D. ROAD

Although the railway plan, design and specified requirements constrain parts of the design, there is scope to work together to find smart and cost-effective solutions. The contractor and the client shall, through cooperation, identify and develop solutions that contribute to increased efficiency and value for the project.

Artist name	Regulations	Doc. no.	Version	Date
VGU	Design guideline	2015:086		2015-06

Scope

Road works shall be carried out in accordance with Table (D).1, "Road sections, bridges/bridge locations, standard cross-sections and references to documents/drawings for the current road works".

Table (D).1. Road sections, bridges/bridge locations and other locations (sites) for the current road construction project.

Group/Location		Standard section	Length of road realignment (km)	Documents/Drawings
Group 1				
	Bridge/location			
Road 608	69+000	Shoulder 0.25 Carriageway 7 Shoulder 0.25	0.7	OLP3-01-114-32-0_0-2200
Road 537	80+790	Support strip 0.25 Carriageway 6.5 Shoulder 0.25	0.39	OLP3-01-114-33-0_0-1200
Road 534	86+050	Support strip 0.25 Carriageway 6 m Shoulder 0.25	0.20	OLP3-01-114-33-0_0-1800

Group 3		Standard section	Length of realignment (km)	Documents/drawings
	Bridge/location			
Private road	64+000	4.0	0.4	OLP3-01-114-32-0_0-1700
Private road	65+500	4.0	0.28	OLP3-01-114-32-0_0-1900
Private road	69+050	4.0	0.1	OLP3-01-114-32-0_0-2300
Private road	72+250	4.0	0.3	OLP3-01-114-33-0_0-0400

Created by
[Created by]
Case number
[Case number]

Document date
[Document date]

Confidentiality level
[Confidentiality level]

Private road	75+250	4.0	0.08	OLP3-01-114-33-0_0-0500
Private road	75+000- 76+250	4.0	1.09	OLP3-01-114-33-0_0-0800 - 0900
Private road	75+650	4.0	0.28	OLP3-01-114-33-0_0-0800
Private road	77+420- 78+200		0.88	OLP3-01-114-33-0_0-0900 - 1000
Private road	80+820- 81+100	4.0	0.27	OLP3-01-114-33-0_0-1100
Private road	82+820	4.0	0.12	OLP3-01-114-33-0_0-1400
Private road	82+940	4.0	0.34	OLP3-01-114-33-0_0-1400
Private road	84+210	4.0	0.34	OLP3-01-114-33-0_0-1700
Private road	86+060 - 86+340	4.0	0.23	OLP3-01-114-33-0_0-1800
Private road	86+200	4.0	0.19	OLP3-01-114-33-0_0-1800
Private road	87+650	4.0	0.67	OLP3-01-114-33-0_0-1900
Private road	88+870	4.0	0.06	OLP3-01-114-33-0_0-2000
Private road	89+730 - 90+200 S	4.0	0.51	OLP3-01-114-33-0_0-2100
Private road	89+730 - 90+200 N		0.51	OLP3-01-114-33-0_0-2100
Private road	89+690	4.0	0.47	OLP3-01-114-33-0_0-2100
Private road	90+220- 90+530		0.37	OLP3-01-114-33-0_0-2200
Private road	90+590- 91+000		0.23	OLP3-01-114-33-0_0-2200
Private road	91+120 - 91+00		0.95	OLP3-01-114-33-0_0-2101
Private road	91+340	4.0	0.63 + 0.81	OLP3-01-114-33-0_0-2300

Created by
[Created by]
Case number
[Case number]

Document date
[Document date]

Confidentiality level
[Confidentiality level]

Group 4		Type section	Length of realignment (km)	Documents/drawings
	Bridge/location			
Service road	64+000N		0.05	OLP3-01-114-32-0_0-1600
Service road	65+250- 65+500 N		0.26	OLP3-01-114-32-0_0-1800
Service road	66+100- 66+200S		0.27	OLP3-01-114-32-0_0-1900
Service road	67+580- 69+000 S		1.75	OLP3-01-114-32-0_0-2000-2300
Service road	69+800– 69+900 S		0.32	OLP3-01-114-33-0_0-0100
Service road	70+400 N		0.58	OLP3-01-114-33-0_0-0200
Service road	71+100 S		0.55	OLP3-01-114-33-0_0-0300
Service road	71+760– 71+850 N		0.11	OLP3-01-114-33-0_0-0300
Service road	72+700– 72+800 S		0.11	OLP3-01-114-33-0_0-0400
Service road	73+900– 74+000 N		0.11	OLP3-01-114-33-0_0-0500
Service road	74+350– 74+500 S		0.23	OLP3-01-114-33-0_0-0600
Service road	76+100– 76+450 N		0.39	OLP3-01-114-33-0_0-0800
Service road	77+450 – 77+520		0.15	OLP3-01-114-33-0_0-0900
Service road	77+920– 78+100 N		0.16	OLP3-01-114-33-0_0-0900
Service road	79+220– 79+920 S		0.7	OLP3-01-114-33-0_0-1100
Service road	80+420 N		0.16	OLP3-01-114-33-0_0-1200

Created by
[Created by]
Case number
[Case number]

Document date
[Document date]

Confidentiality level
[Confidentiality level]

Service road	80+420– 80+480 N		0.06	OLP3-01-114-33-0_0-1200
Service road	80+800		0.01	OLP3-01-114-33-0_0-1200
Service road	81+500– 81+620 S		0.12	OLP3-01-114-33-0_0-1300
Service road	82+080– 82+480 S		0.43	OLP3-01-114-33-0_0-1400
Service road	84+020– 84+210 N		0.13	OLP3-01-114-33-0_0-1600
Service road	84+150– 86+250 S		0.19	OLP3-01-114-33-0_0-1600–1700
Service road	86+060– 87+120 S		1.07	OLP3-01-114-33-0_0-1800-1900
Service road	87+800– 88+050 S		1.1	OLP3-01-114-33-0_0-1900–2000
Service road	88+690- 89+350		0.49	OLP3-01-114-33-0_0-2000-2100
Service road	90+120– 90+240 S		0.27	OLP3-01-114-33-0_0-2200

Function

The facility shall be designed in accordance with Table (D).1.

The proportion of traffic using studded tyres during the period 1 October to 15 April is 70%.

The facility shall be designed for BK1.

Standard axle is defined in accordance with TRVINFRA-00224, Chapter 12.3.1.

All design shall be based on a road safety approach. The traffic environment shall have a forgiving design and the needs of vulnerable road users shall be taken into account.

The road facility shall be designed and constructed in such a way that the requirements in the following publications/documents are met:

“Requirements – VGU” (Groups 1 and 2).

“VGU – Concepts and Core Values”.

The Swedish Transport Administration’s publication 2021:089, HANDBOOK Design and Construction of Private Roads, version 1.0 dated 17 March 2021. (Group 3)

Swedish Forest Agency, Guidelines for the design and construction of Class III and IV2 forest roads, where Class III and Accessibility Class A must be selected. (Group 4)

Created by
[Created by]
Case number
[Case number]

Document date
[Document date]

Confidentiality level
[Confidentiality level]

Requirements for the technical service life of structures, equipment and systems included in road construction normally presuppose operational and maintenance work.

Operation and maintenance must be capable of being carried out efficiently and using modern methods, and in such a way that the existing land and environment or structures are not adversely affected and functions are not impaired.

The distance from the centre of the nearest railway track to the roadside must be at least 25 metres. If, due to special circumstances, it is not possible to maintain a safety distance of 25 metres, a risk assessment must be carried out in which the specific situation is assessed on the basis of local conditions. Where necessary, measures must be taken and implemented.

If the road is higher than the railway or less than 2 metres lower than the railway (RÖK), a risk assessment must be carried out if it is likely that vehicles leaving the road could reach the railway. This also applies when the distance is greater than 25 metres. Where necessary, measures must be taken to effectively ensure that vehicles cannot end up on the track, come into conflict with rail traffic or interfere with track infrastructure. Measures may include the installation of protective barriers, such as road barriers or other barriers between the road and the track.

Level crossings with the railway must not be permitted.

Unless otherwise specified, the following applies: road overpasses and underpasses where the Ostlänken passes over must be designed with a clearance height of at least 4.7 m and an opening width of at least 7 m. This includes all roads or other planned crossings required for transport within properties that have been cut off as a result of the Ostlänken.

Crossings under the railway infrastructure for national roads must be at least 6 metres wide with a 1-metre strip on either side of the road.

Below are sections schematically illustrated for intersecting state roads along the line.

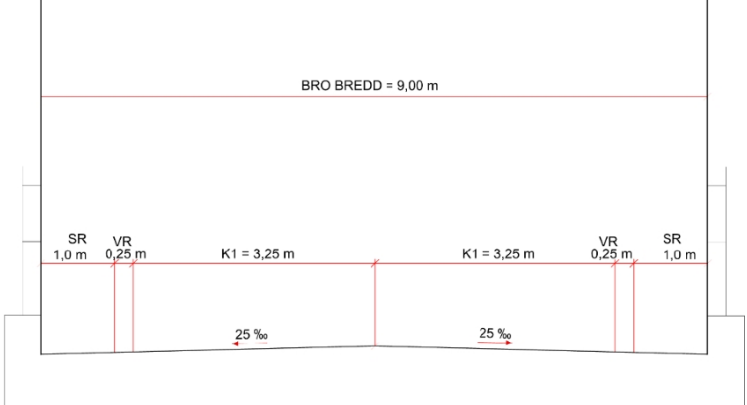
Table (D).2. Group	Section: gate/bridge	Comment
Group 1		
Road 608 KM 69+000		State Road 608 on a bridge over the railway line, road width 7.0 metres.

Created by
[Created by]
Case number
[Case number]

Document date
[Document date]

Confidentiality level
[Confidentiality level]

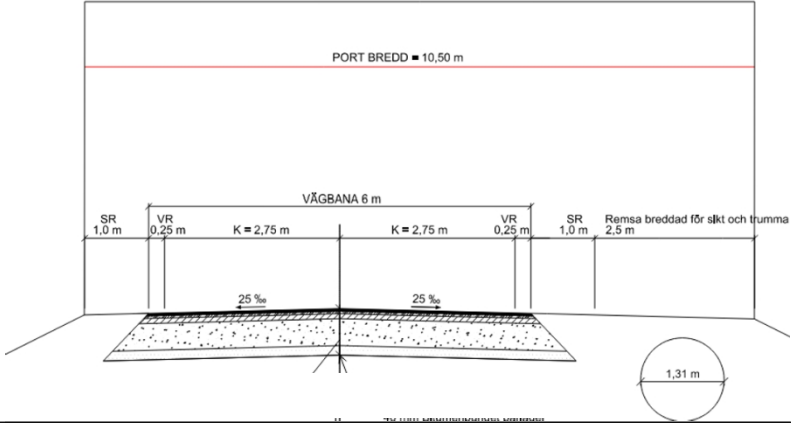
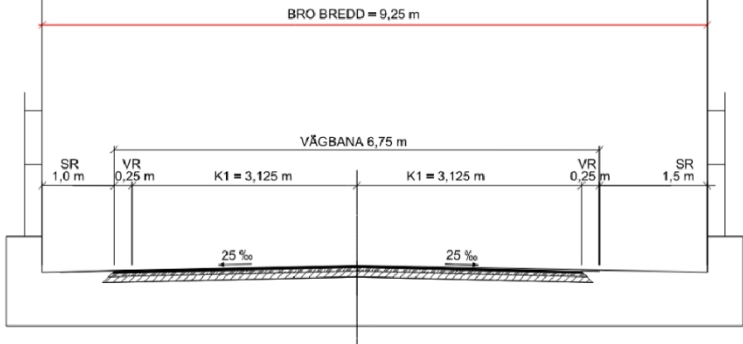
Road 610		State Road 610 passing through a gate. Gate widened on the right-hand side for visibility and culvert.
Road 537 km 80+790		State Road 537 on a bridge over the railway line. Road width 6.7 metres
	Road 52 is not included as the railway crosses the road via a landscape bridge.	

Requirements for the technical service life of structures, equipment and systems included in the road infrastructure presuppose normal operation and maintenance work. Operation and maintenance must be capable of being carried out efficiently and using modern methods, and in such a way that the existing land and environment or structures are not adversely affected and functions are not impaired.

D. Road// Group 1

Scope As per Table D.

(1) Function

The road infrastructure shall, in terms of road design and structural dimensioning, be designed for expected traffic volumes 20 years after the planned final inspection. The design shall also meet service level requirements during the design hour (DH-Dim) and peak hour (DH-Max).

Traffic changes, DH-Dim, DH-Max and year for Group 1 apply in accordance with traffic load Table (D).11 applies".

Table (D).11 Group 1, design and dimensioning requirements. Total traffic $AADT_t = \text{Total traffic flow in both directions of the road.}$

Created by
[Created by]
Case number
[Case number]

Document date
[Document date]

Confidentiality level
[Confidentiality level]

Location/section	Road type	VR [km/h]	AADT	Heavy traffic	Annual change in traffic Pb/year	Annual change in traffic Lb/year	B-factor (adjusted)
Road 608 1603_608	Two-lane road	70	1610	10	1%	1%	1.3
Road 537 1802_537	Two-lane road	70	1000	10%	1%	1%	1.3
Road 534 1901_534	Two-lane road	70	1000	10%	1%	1%	1.3

For roads as per Table (D).11, DH-Dim is 9.5% and DH-Max is 12.5% of the AADT for the design year (20 years after the year specified in Table (D).11 with a change in traffic)

Where standard design requirements are not specified in the tender documentation, the design shall comply with the “new construction standard” for the respective speed and road type in accordance with “Requirements – VGU”.

In the case of roadside areas with embankments and safety zones as specified in the tender documents, local guardrails may be required where the design cannot meet the requirements in “Requirements – VGU”, e.g. in the case of high embankments and drops or where immovable objects cannot be avoided.

In connection with the passage of road gates and road bridges, the design shall be in accordance with Table (D).2.

D. Road// Group 1/ Temporary road

Scope

Group/ Location		Standard section	Length of road realignment (km)	Documents/Drawings (planning documents)
Group 1				
	Bridge/locati on			
Road 52	64+560		0.35 (temporary)	OLP3-01-111-32-0_0 - 1800
Road 216	77+430		0.32 (Temporary)	OLP3-01-111-33-0_0 - 0900
Road 534	86+050		0.07 (temporary)	OLP3-01-111-33-0_0 - 1800

Function

The design technical service life shall correspond to the current period of use. The road facility shall be lit in the same way as the connecting road.

Created by
 [Created by]
Case number
 [Case number]

Document date
 [Document date]

Confidentiality level
 [Confidentiality level]

Road markings shall be applied to a paved surface over a continuous length of at least 100 m.

Road markings shall have a retroreflectivity of ≥ 150 mcd/m². Temporary road markings shall be applied in accordance with “TRVK Apv”.

Requirements regarding conditions for temporary traffic are specified in AF, AFD.135.

D. Road// Group 3

Function

The road construction shall be designed and executed in accordance with “Design and Construction of Private Roads”, Chapters 4.3–4.5.//

Junctions with roads belonging to Group 1 shall meet the requirements for such a road. Farm access roads shall be designed with appropriate gradients, slopes and radii.

The road construction shall be designed and executed in accordance with “Design and Construction of Private Roads”, Chapter 6. Traffic load according to Table (D).13

Table (D).13 Group 3. Requirements for design, dimensioning and inspection

Location	Section	Wearing course	VR (km/h)	AADT [vehicles/day]	Climate zone	Comment
		Gravel	50	50	2	

Inspection

Inspections shall be carried out in accordance with “Design and Construction of Private Roads”.

D. Road// Group 4

Function

The road construction shall be designed in accordance with the drawings and other documents in the tender documentation.

The road must be adapted to the surrounding terrain but with a consistent standard of vertical and horizontal alignment, and in such a way that the new road does not cause difficulties for residents or the use of the surrounding land.

Road or farm connections shall be designed with appropriate landings, gradients and radii. Connections to other roads shall be designed in accordance with the requirements for the respective road type to which they connect.

Access for maintenance of stormwater storage basins must be provided via a service road with turning space for LOS vehicles.

It must be possible to drive into the service yard with LOS-sized vehicles for the replacement of components. Vehicles must be able to reverse out and turn round outside, unless a turning area is provided within the service yard.

Passing places shall be single-sided and designed for LBN-type vehicles in accordance with VGU, and shall be located approximately 500 m apart. When locating passing places, unobstructed sightlines between them shall be ensured.

Two-way vehicles must be able to access the track via access ramps adjacent to maintenance bases and/or via gates along the track.

Created by
[Created by]
Case number
[Case number]

Document date
[Document date]

Confidentiality level
[Confidentiality level]

Provisions for winter maintenance must be in place; the design must allow for snow management, snow storage and snow clearance so that the facility is not damaged.

A road with an associated service vehicle area must be provided up to the technical building.

A road must be provided in close proximity to the kiosk and the curve.

Access roads and parking areas for network stations must be designed to allow for loading and unloading, including the turning of transport vehicles.

Connection points must have identification numbers. The identification numbers of the connection points must be clearly marked on two signs, one of which is placed on the inside and one on the outside of the physical barrier and adjacent to the connection point.

Service roads must be constructed to access turning areas, unloading areas and parking areas. The service roads must be marked on the emergency response plan, with GPS coordinates.

Service routes must be established leading to cabinets containing track circuit equipment.

The location of turning areas and/or vehicle parking spaces must be determined on the basis of the local solution so as not to obstruct public traffic.

Pedestrian crossings must be provided along the track to enable maintenance staff to cross the tracks safely to reach maintenance sites.

Specifically for service roads on bridges longer than 1000 m:

- The location of service roads must be adapted so that there is a connection to the track at both bridge abutments. The connection must be constructed along a line alongside the track that is a maximum of 200 m long, starting at the bridge abutment.
- It must be possible to park three LOS vehicles (area: length 35 m, width 3 m) and manoeuvre LBn vehicles outside the perimeter protection of technical buildings. The manoeuvring area for LBn vehicles may encroach upon the parking space for one LOS vehicle.
- Areas for turning and parking vehicles shall be located along a line running alongside the track, which is a maximum of 200 m long, starting at the bridge abutment.
- The distance between the junction/gate, the associated bridge (longer than 1000 m) and the turning area/unloading area must not exceed 50 metres.

The design must meet the requirements set out in “Swedish Forest Agency, Guidelines for the design and construction of Class III and IV forest roads”. Traffic load is shown in Table (D).14.

Table (D).14 Group 4. Conditions for design, dimensioning and inspection.

Location	Section	Road class	Accessibility class	Comment
All		3	A	

Service roads, including turning areas, shall be designed for standard vehicles LBn and LOS in accordance with VGU.

Created by
[Created by]
Case number
[Case number]

Document date
[Document date]

Confidentiality level
[Confidentiality level]

The Swedish Transport Administration's type vehicle LBN shall be used for the design of service roads. The vehicle's dimensions are: length 12.0 m, width 2.55 m, height 4.5 m and turning radius 12.0 m.

The maximum permitted longitudinal gradient for service roads is

7%. Service roads shall be dimensioned to safety class SK2.

Inspection

Inspection shall be carried out in accordance with the requirements in "Swedish Forest Agency, Guidelines for the design and construction of Class III and IV forest roads".

D. Roads// Group 4/ Technical yards

Function

Technical yards must be elevated so that the working level of the technical yard is not exceeded at water levels with a return period of at least 100 years, as determined in accordance with the Ostlänken climate protection document currently in force.

The service level for technical yards shall be defined as the level 0.1 m below the ground surface on which the technical yard is located.

If a utility yard is situated more than 0.9 m below RÖK, a flood analysis must be carried out and documented.

DB. Road construction

DB1. Superstructure

Function

The hard shoulder shall be dimensioned in the same way as BK1.

For road sections with only one carriageway in each direction, the total superstructure thickness shall be the same for the entire road, including hard shoulders. The superstructure shall be dimensioned for the most heavily loaded carriageway or the total traffic, depending on the road width and standard section.

DB1. Superstructure// Group 1

Function/Service life

The road structure and subgrade shall be designed and constructed with design service lives in accordance with Table (DB1).3. The service life shall be calculated from the year of final inspection.

Table (DB1).3. Design technical service life.

Part	Time (years)
Bituminous layers	20
Hydraulically bound layers	40
Subgrade and subbase	40

Created by
 [Created by]
Case number
 [Case number]

Document date
 [Document date]

Confidentiality level
 [Confidentiality level]

Part	Time (years)
Reinforcement of subsoil	80

Function/Load-bearing capacity

The superstructure in road construction shall be designed and constructed to full bearing capacity with loads in accordance with TRVINFRA-00224, Chapter 12.

Function/ Frost heave, frost cracks

Uneven frost heave must not occur. Uneven frost heave is defined as sections with a damage rating of 2 or higher in accordance with TDOK 2013:0669, Chapter 2.3.

The superstructure in road construction shall be designed and constructed so that the requirements for frost heave specified in Table (DB1).1 are met.

A specific specification shall be drawn up and shall describe and refer to scientifically documented methods or established and proven methods.

The difference in frost heave between the road and the connecting road shall not exceed 30 mm along the length of the junction curve.

Longitudinal unevenness must not at any time during the year exceed 15 mm when measured with a 3-metre straightedge or levelling.

Transverse unevenness must not at any time during the year exceed 30 mm, measured using a 3-metre straightedge or levelling.

At the transition between terrace materials with different frost heave properties, the frost heave measured longitudinally must not vary by more than 5 mm per metre. Calculations must demonstrate how this is achieved.

Inspection/Bearing Capacity

The bearing capacity shall be checked and evaluated during the final inspection by means of a drop weight test in accordance with "TDOK 2019:0463 'Evaluation of the bearing capacity of road structures using a drop weight apparatus'".

Inspection/Frost heave

The specified type of material for the sub-base must be checked during construction.

DB11b. Road surface

DB11b. Road surface/Bound wearing course

Function/Friction

Paved roads with a reference speed of ≥ 70 km/h must, in dry conditions, have a friction coefficient of ≥ 0.50 for each 20 m section.

Other roads, as well as roundabouts, junctions and bus stops, must have a coefficient of friction of ≥ 0.55 over a 20-metre stretch in dry conditions.

The lateral coefficient of friction must not vary by more than 0.25 at any time.

Function/ Stone dislodgement and wear losses

Created by
[Created by]
Case number
[Case number]

Document date
[Document date]

Confidentiality level
[Confidentiality level]

Stone dislodgement and service losses must not occur. The difference in test surfaces between damaged and undamaged sections, measured in accordance with “SS-EN 13036-1, Sand-patch method. Surface properties of roads and airfields – Test methods – Part 1: Measurement of the depth of macrotexture of a pavement surface by a volumetric method”, must not exceed 20%.

Function/ Potholes Potholes

must not be present. **Inspection/**

Friction

Inspection in accordance with TDOK 2014:0134 “Determination of road friction” shall be carried out at the final inspection.

Inspection of the lateral friction coefficient by measuring in two lines, one of which is in the left-hand wheel track, is carried out at the final inspection.

Inspection of road marking friction is carried out in accordance with TDOK 2013:0461 “Mobile inspection of road markings” or TDOK 2013:0462 “Hand-held inspection of road markings” during the final inspection.

Inspection/Stone loss and wear

Cracks are identified and analysed (mapped) in accordance with “Hold or Break – Handbook on Condition Assessment of Paved Streets and Roads”.

The measurement length for damaged sections is divided into 20-metre sections for the current work phase. On a damaged 20-metre section, 10 measurements are taken in the area or areas deemed most exposed.

The average of these 10 measurement values represents the respective damaged 20-metre section.

Undamaged road sections are divided into sections with measurement lengths of less than 100 metres. Measurements will be taken at 10 randomly selected points on each such section. The average of these 10 measurement values represents the respective undamaged section.

The value for each damaged 20-metre section is compared with the value for undamaged pavement.

DB11b. Road surface/ Binder course// Group 1

Function/ Longitudinal and transverse evenness measured with a straightedge

Where it is not possible to measure using a measurement vehicle in accordance with “TDOK 2014:0005”, requirements for longitudinal and transverse evenness measured with a straightedge in accordance with “TDOK 2014:0136” apply, as per Table (DB1).7 for the relevant reference speed.

Measurements shall be carried out on affected sections of Group 1 roads 608, 537 and 534

Table (DB11).1. Longitudinal and transverse evenness measured using a straightedge.

Reference speed VR (km/h)	Acceptance range for control point
VR 50 km/h	A o B : ≤3 C : ≤4
VR 60 km/h	A-C or B-C : ≤4
VR 70 km/h	A o B : ≤2 C : ≤4
VR 80 km/h	A-C or B-C : ≤3

Created by
[Created by]
Case number
[Case number]

Document date
[Document date]

Confidentiality level
[Confidentiality level]

The requirements in Table (DB1).7 apply at final inspection. During the warranty period, the requirements in Table (DB1).7 apply multiplied by the following factors:

Adjacent to bridges, over a distance of 6.0 m before and 6.0 m after the bridge transition structure, unevenness in the road surface must not exceed 6.0 mm relative to a 5 m long straightedge laid out in the longitudinal direction of the road. A difference of more than 10 mm between the transition structure and the lower edge of the straightedge is not acceptable.

The surface of the carriageway adjacent to the transition structure shall be 5.0 mm higher than the top surface of the transition structure, with a tolerance of +3 and -2 mm respectively.

Function/Crossfall measured with a straightedge

Where it is not possible to measure using a measuring vehicle in accordance with “TDOK 2014:0005”, the requirements for cross-slope deviation measured with a straightedge in accordance with “TDOK 2014:0136” shall apply for the relevant cross-slope class as per Table (DB1).10.

Measurements shall be carried out on affected sections of Group 1 roads 608, 537 and 534

Table (DB11).2. Cross-slope deviation measured with a straightedge during final inspection.

Reference speed VR (km/h)	Test section	Road section of 400 m in length or a lane of 800 m in length.
VR 50 km/h	Acceptance range at final inspection.	$s \leq 0.45$ — x within $\pm(0.55-0.46s)$
VR 50 km/h	Acceptance interval during the warranty period	$s \leq 0.70$ — x within $\pm(0.75-0.46s)$
VR 70 km/h	Acceptance interval at final inspection.	$s \leq 0.40$ — x within $\pm(0.50-0.46s)$
VR 70 km/h	Acceptance interval during the warranty period	$s \leq 0.65$ — x within $\pm(0.70-0.46s)$

Function/Cracks

Cracks must not exceed the equivalent of a crack index of 5, assessed in accordance with VTI Report 916:2001 (development of degradation models) and “Stand or Break – Handbook on Condition Assessment of Paved Streets and Roads”.

Function/ Local unevenness

Local unevenness must not exceed 6 mm when measured with a 3 m straightedge.

Inspection/Function

Created by
[Created by]
Case number
[Case number]

Document date
[Document date]

Confidentiality level
[Confidentiality level]

Inspection of the completed road structure shall be carried out through the prescribed inspection of the road surface prior to final inspection.

Inspection/Function/Longitudinal and transverse evenness and cross-slope deviation measured with a straightedge

If measurement cannot be carried out using a measuring vehicle in accordance with “TDOK 2014:0005”, measurement shall be carried out using a straightedge in accordance with “TDOK 2014:0136” and “VVMB 908”.

Measurements shall be carried out on affected sections of Group 1 roads 608, 537 and 534

Longitudinal and transverse evenness measured with a straightedge shall be checked in accordance with Tables (DB1).13a and (DB11).3a and the applicable reference speed.

Table (DB11).3a. Measurement procedure and criteria variables for measuring longitudinal and transverse evenness using a straightedge.

Test section	A road section 400 m in length or a carriageway 800 m in length.
Random sampling	n=15, control points selected longitudinally and transversely within the test section in accordance with the procedure described in “TDOK 2014:0136” and “VVMB 908”
Measurement procedure	Measurements shall be carried out in accordance with “TDOK 2014:0136”
Measurement variables	Deviation from the straightedge standard at each of the straightedge’s measurement points (1, 2 and 3)
Criteria variables	At each control point: A: Deviation from the straightedge standard at measurement point 1 B: Deviation from the straightedge standard at measurement point 3 C: Deviation from the straightedge standard at measurement point 2 Difference between A and C, and between B and C Proportion of control points with acceptable values for all criterion variables.

Table (DB11).3b. Criteria for approval of requirements for longitudinal and transverse evenness measured with a straightedge.

Reference speed, VR	Selection probability for inspection objects	Number of approved control points
VR 50 km/h – VR 90 km/h	1/2	12 out of 15

At bridge junctions, the evenness of the road surface must be checked 6 m before and 6 m after the bridge relative to a five-metre-long straightedge laid in the longitudinal direction of the road. The height of the surfacing above the transition structure is measured using the same straightedge.

Created by
[Created by]
Case number
[Case number]

Document date
[Document date]

Confidentiality level
[Confidentiality level]

The surface of the pavement adjacent to the transition structure shall be measured using a straightedge placed across the transition structure in the direction of travel; the straightedge shall be at least as long as the length of the transition structure in the direction of the road plus 400 mm, but not less than 1 m.

Crossfall deviation measured with a straightedge shall be checked with a straightedge during the final inspection in accordance with Table (DB11).4.

Table (DB11).4. Measurement procedure for measuring cross-slope deviation using a straightedge during the final inspection.

Inspection object	Road section of 400 m in length or a lane of 800 m in length. Inspection objects are selected for examination with a sampling probability of 1/2, see "VVMB 908".
Random sample	n=15, control points selected longitudinally and transversely within the inspection object in accordance with the procedure described in "TDOK 2014:0136" and "VVMB 908"
Measurement procedure	Measurements are carried out using a 3 m straightedge with an inclinometer attached. Measurements shall be carried out in accordance with "TDOK 2014:0136".
Measurement variables	The measurement variable is the deviation from the reference value for the slope of the road surface across the road, measured as a percentage.
Criteria variables	\bar{x} , s

DB11b. Road surface/ Unbound wearing course

DB11b. Road surface/ Unbound wearing course// Group 3

Scope

All roads under Group 3 in Table (D).1. shall be provided with an unbound wearing course.

Function

The wearing course shall be constructed with a levelness tolerance of no more than 9 mm, measured using a 3 m straightedge. The cross-slope of the road surface shall not be less than 3%.

Technical solution

Micro-Deval values determined in accordance with SS-EN 1097-1 must not exceed 20. Micro-Deval values must also not be below 7.

Unbound wearing courses shall be dust-bound with calcium chloride, approx. 0.5 kg/m², emulsion or equivalent.

Inspection/Function

A check for evenness shall be carried out during the final inspection. The check shall be carried out by measuring the deviation from a 3 m long straightedge, laid in any direction on the gravel wearing course.

When checking cross-slope, the straightedge must be fitted with a slope gauge.

Created by
[Created by]
Case number
[Case number]

Document date
[Document date]

Confidentiality level
[Confidentiality level]

The straightedge and inclinometer shall meet the requirements of “TDOK 2014:0136”.

Inspection/Technical solution

The abrasion properties of materials in the finished layer shall be checked in accordance with SS-EN 1097-1. Sampling shall be carried out at least once per 20,000 m², but at least twice per project and quarry.

The proportion of uncrushed material shall be checked in accordance with SS-EN 933-5.

The thickness of unbound wearing courses shall be checked by levelling before and after laying. Such levelling shall be carried out every 20 metres with at least three points per section.

Material samples shall be taken from the finished course in accordance with “TDOK 2014:0151”.

DB11b. Road surface/ Unbound wearing course// Group 4

Scope

All roads under Group 4 in Table (D).1. shall be provided with an unbound wearing course.

Function

The unbound wearing course shall be constructed with a level tolerance of no more than 9 mm, measured using a 3 m straightedge.

Technical solution

Micro-Deval values determined in accordance with SS-EN 1097-1 must not exceed 20. Micro-Deval values must also not be below 7.

The proportion of uncrushed material > 8 mm must be less than 50% by weight. The thickness of unbound wearing courses must be 50 mm.

Unbound wearing courses shall be homogeneous and free from segregation.

Unbound wearing courses shall be dust-bound with calcium chloride, approx. 0.5 kg/m², emulsion or equivalent.

Inspection/Function

Inspection for evenness shall be carried out during the final inspection. Inspection shall be carried out by measuring the deviation from a 3 m long straightedge, laid in an arbitrary direction on the gravel wearing course.

When checking cross-slope, the straightedge shall be fitted with a slope gauge. The straightedge and slope gauge shall meet the requirements of “TDOK 2014:0136”.

Inspection/Technical solution

The proportion of uncrushed material shall be checked in accordance with SS-EN 933-5.

The thickness of unbound wearing courses shall be checked by levelling before and after laying. Such levelling shall be carried out every 20 metres with at least three points per section.

Material samples for checking grain size distribution shall be taken from the finished layer.

Material samples shall be taken from the finished layer in accordance with “TDOK 2014:0151” at least once per 20,000 m², but at least twice per project and quarry.

Created by
[Created by]
Case number
[Case number]

Document date
[Document date]

Confidentiality level
[Confidentiality level]

DB12c. Unbound layer

DB12cb. Base course

DB12cb Base course// Group 1

Technical solution

The proportion of free mica in road layers must not exceed 30% in accordance with the method specified in TDOK 2013:0530 Unbound layers for road structures, Chapter 7.2.1.6. This applies even if the layer will not be subject to traffic.

Inspection/Technical solution

Checks for free mica must always be carried out in accordance with the method and frequency described in TDOK 2013:0530 Unbound layers for road structures, Chapter 7.2.1.6, regardless of whether there is a suspicion of high mica content or not.

DB12cb. Base course// Group 3

Function

The unbound base course shall be constructed with a levelness tolerance of no more than 9 mm, measured using a 3 m straightedge.

The abrasion properties of materials in the finished layer, expressed as the Micro-Deval value determined in accordance with SS-EN 1097-1, must not exceed 30. For roads to be paved, the Micro-Deval value in accordance with SS-EN 1097-1 must not exceed 20. If the base course is not subject to traffic, Micro-Deval values of up to 25 are permitted.

The proportion of uncrushed material >16 mm must be less than 50% by weight. The base course must be homogeneous and free from segregation.

Inspection/Function

Checking for evenness shall be carried out by measuring the deviation from a 3 m long straightedge, laid in any direction on the base course.

The abrasion properties of materials in the finished layer shall be checked in accordance with SS-EN 1097-1. Sampling shall be carried out in accordance with "TDOK 2014:0151" at least once per 20,000 m², but at least twice per project and quarry.

The proportion of uncrushed material shall be checked in accordance with SS-EN 933-5.

The thickness of the base course shall be checked by levelling before and after laying. Such levelling shall be carried out every 20 metres with at least three points per section.

Compaction results shall be recorded in a log.

Material samples for checking grain size distribution shall be taken from the finished layer.

Material samples shall be taken from the finished layer in accordance with "TDOK 2014:0151".

DB12cb. Base course// Group 4

Function

The unbound base course shall be constructed with a levelness tolerance of no more than 9 mm, measured using a 3 m straightedge.

Created by
[Created by]
Case number
[Case number]

Document date
[Document date]

Confidentiality level
[Confidentiality level]

The abrasion properties of the material in the finished base course, expressed as the Micro-Deval value determined in accordance with SS-EN 1097-1, must not exceed 30 for unpaved roads. For roads to be paved, the Micro-Deval value according to SS-EN 1097-1 must not exceed 20. If the sub-base is not subject to traffic, Micro-Deval values of up to 25 are permitted.

The sub-base must be constructed homogeneously and free from segregation.

Inspection/Function

Inspection of evenness shall be carried out by measuring the deviation from a 3 m long straightedge, laid in any direction on the base course.

The proportion of uncrushed material shall be checked in accordance with SS-EN 933-5.

The thickness of the base course shall be checked by levelling before and after laying. Such levelling shall be carried out every 20 metres with at least three points per section.

Compaction results shall be recorded in a log.

Material samples for checking grain size distribution shall be taken from the finished layer in accordance with "TDOK 2014:0151" at least once per 20,000 m², but at least twice per site and quarry.

DB12cc. Reinforcement layer DB12cc.

Reinforcement layer// Group 3 Function

The reinforcement layer shall be constructed with a levelness tolerance of no more than 12 mm, measured using a 3-metre straightedge.

For material in the finished layer on roads with an unbound wearing course, the Micro-Devalue determined in accordance with SS-EN 1097-1 must not exceed 30.

The proportion of uncrushed material shall be less than 50% by weight. The reinforcement layer shall be constructed homogeneously and free from segregation. **Inspection/Function**

Checking for evenness shall be carried out by measuring the deviation from a 3 m long straightedge, laid in an arbitrary direction on the reinforcement layer.

The proportion of uncrushed material shall be checked in accordance with SS-EN 933-5.

The thickness of the reinforcement layer shall be checked by weighing before and after laying. Such weighing shall be carried out every 20 metres with at least three points per section.

Compaction results shall be recorded in a log.

Material samples for checking the particle size distribution shall be taken from the finished layer in accordance with "TDOK 2014:0151".

DB12cc. Reinforcement layer// Group 4

Function

Created by
[Created by]
Case number
[Case number]

Document date
[Document date]

Confidentiality level
[Confidentiality level]

The reinforcement layer shall be constructed with a levelness tolerance of no more than 12 mm, measured using a 3-metre straightedge.

For materials in the finished layer on roads with an unbound wearing course, the Micro-Devalue determined in accordance with SS-EN 1097-1 must not exceed 30.

The reinforcement layer shall be constructed homogeneously and free from segregation.

Inspection/Function

Inspection of evenness shall be carried out by measuring deviation from a 3 m long straightedge, laid in an arbitrary direction on the reinforcement layer.

The thickness of the reinforcement layer shall be checked by levelling before and after laying. Such levelling shall be carried out every 20 metres with at least three points per section.

Compaction results shall be recorded in a log.

Material samples for checking the particle size distribution shall be taken from the finished layer in accordance with "TDOK 2014:0151" at least once per 45,000 m², but at least twice per project and quarry.

DB3. Sub-base

Function/Service life

The sub-base shall be designed and constructed with design service lives in accordance with Table (DB1).3. The service life shall be calculated from the year of final inspection.

DB4. Subsoil

Function

Function/Service life

The sub-base shall be designed and constructed with design service lives in accordance with Table (DB1).3. The service life shall be calculated from the year of final inspection.

Function/ Ground reinforcement

Vertical drainage must not be carried out within designated groundwater bodies or in areas with soil and groundwater contamination.

The presence of quick clay must be taken into account when installing mixing piles to minimise the risk of landslides.

The use of alternative binders for deep stabilisation requires special approval. The use of alternative binders must be notified in advance.

Reinforcement measures for roads shall be designed and constructed in accordance with TRVINFRA-00230, Geotechnical Engineering, Design and Layout, and TRVINFRA-00229, Geotechnical Engineering, Administrative Rules.

Created by
[Created by]
Case number
[Case number]

Document date
[Document date]

Confidentiality level
[Confidentiality level]

Technical solution/Rock excavation

Deep blasting shall be carried out to 1.5 m below terrace level. However, the deviation between the excavated and theoretical rock contours on the outer rock slopes must not exceed 0.7 m at the base of the slope.

Clearing shall be carried out so that the rock surface is completely free of soil and loose stones.

When blasting in the vicinity of a railway, TDOK 2015:0223 “Electrical safety regulations for work on or near railway-related high-voltage and train heating installations” applies.

Electronic detonators must be used provided that TDOK 2015:0223 “Electrical safety regulations for work on or near railway-related high-voltage and train heating installations” permits this. Where high-voltage power lines are located within 100 m of a planned rock excavation, a different type of detonator may need to be used in the vicinity of these installations. Consultation with the installation owner must take place before blasting work commences in the vicinity of these installations.

Factory-capsulated explosives or tubular charges must be used.

Based on the results of vibration measurements, any corrective measures must be taken for each blast and recorded in the blasting log. In the event of exceedances, a non-conformity report must be drawn up.

Blasting work and other vibration-generating work must be carried out in accordance with the restrictions set out in the “Risk Analysis of Vibration-Generating Activities during Construction” (provided after contract signing).

For sections involving rock cutting, Geotechnical Category 2 shall apply.

Rock cutting shall be classified as Safety Class 2.

Inspection

Inspection programmes with associated inspection plans shall detail the necessary checks to verify that the conditions and assumptions made in the design are met.

DB5. Construction in the side area

Function

No unclad surfaces with crushed or blasted rock shall be present in the side area. Backfill material shall correspond to the surrounding soil type.

Technical solution

Side areas shall be covered with topsoil, at least 0.1 m thick.

In the absence of suitable topsoil, poor-quality topsoil or poor-quality topsoil material shall be applied (whichever is most cost-effective).

All seed mixtures must be of Swedish origin and adapted to the site’s habitat type and conditions, as well as being low-growing and hardy. They must be able to establish themselves quickly and have a deep root system that binds the soil and thus prevents erosion. Seed mixtures must be species-rich and contain herbs and grass species found on the site, as specified on the basis of species inventories.

Meadows and grasslands shall be mown in August/September. Mown plant material shall be removed 1–2 weeks after mowing.

Created by
[Created by]
Case number
[Case number]

Document date
[Document date]

Confidentiality level
[Confidentiality level]

DB51. Slope

Function

Where there is a boundary with an existing road or an adjacent development phase, the slopes must be designed and surfaced in such a way that the transition between phases is not noticeable at the end of the warranty period.

Technical solution

The crest and toe of the slope shall be rounded, and there must be no steps within the safety zone.

Slopes shall be covered with excavated material from areas with the same type of vegetation as the surrounding area to encourage natural establishment of low ground-covering herbaceous/grass vegetation.

Slopes shall be sown with a grass and meadow seed mixture adapted to the site conditions and corresponding to the site's other vegetation.

Inspection

A control plan to ensure the establishment of vegetation during the construction period and the warranty period shall be drawn up. The plan shall also specify the stages of vegetation management to be documented in text and photographs. A maintenance programme for the care of vegetation areas and plant beds during the warranty period shall be drawn up.

At the warranty inspection, 100% establishment must have been achieved on slopes. "

DB51c. Outer slope

Technical solution Eriksgatan km 84+212

Stavsjö-Krokek (Eriksgatan) km 84+212 must be harmonised so that the embankment of the road bridge and the road embankment have the same gradient, and the bridge's wing and retaining wall have the same gradient as the road.

DB51c. Outer slope/Rock

Function

Rock outer slopes must be surface-stable and structurally stable, and deliberately designed.

Surface stability refers to conditions along the surface of the rock cut – the presence of loose stones and boulders. Structural stability refers to conditions affecting the entire rock cut – risk of slippage/landslides.

Loose stones or boulders must not remain on the slope.

Rockfall debris must not encroach on the traffic area or pose a traffic safety risk.

Technical solution

During blasting, the blast areas must be covered with double weighting. When blasting within 50 metres of buildings, masts, overhead lines, infrastructure and other structures, the double weighting must be supplemented with splinter protection, geofilter class N5 or equivalent.

When blasting in the vicinity of a railway, TDOK 2015:0223 "Electrical safety regulations for work on or near railway-related high-voltage and train heating installations" applies.

Created by
[Created by]
Case number
[Case number]

Document date
[Document date]

Confidentiality level
[Confidentiality level]

Electronic detonators shall be used provided that TDOK 2015:0223 “Electrical safety regulations for work on or near railway-related high-voltage and train heating installations”, Chapter 11.7, permits this. Where high-voltage power lines are present within 100 m of rock excavations, a different type of detonator may need to be used. Consultation with the facility owner must take place before blasting work commences in the vicinity of these facilities.

In areas sensitive to nitrogen leakage from blasted rock, factory-capsulated explosives must be used.

All rock reinforcement must be designed for a technical service life of TLK 120. Clearing must be carried out so that the rock surface is completely free of soil and loose rocks.

Clearing behind the slope crest must be carried out down to the rock surface and at least 1.5 m beyond the final slope crest. Where boulders protrude from the slope crest, the clearing must be adapted so that the area is cleared 1.5 m beyond the slope crest. A description of the method and execution for all works shall be drawn up. The intended execution, such as rock excavation and reinforcement, shall be reported. Existing rock engineering survey results shall be evaluated and supplemented where necessary.

Based on vibration measurement results, any corrective measures must be taken for each blast and recorded in the blasting log. In the event of exceedances, a deviation report must be drawn up.

Blasting work and other vibration-generating work must be carried out in accordance with the restrictions set out in the “Risk Analysis of Vibration-Generating Activities during Construction” (provided after contract signing).

If there is a risk of water flowing out of a rock cut, or if water from above could pose a risk of ice formation, measures to minimise the risk of ice formation must be taken.

Technical solution// Slopes steeper than 1:1, case 1

On rock faces with a gradient steeper than 1:1, the blast damage zone in the remaining rock must not exceed 0.3 m. The deviation between the excavated and theoretical rock contours must not exceed 0.3 m on the slope face and 0.7 m at the base of the slope.

Technical solution// Slopes gentler than 1:1

Slopes with gradients between 1:1 and 1:2 should, as far as possible, follow the natural contours of the land.

Slopes flatter than 1:2 shall, if they do not follow natural contours, be covered with soil so as to achieve visual uniformity with surrounding/adjacent earth slopes.

Inspection

Following the uncovering of the rock surface, the client shall be given the opportunity to be present at the site inspection to verify the design parameters. The designed slope crest shall then be marked out in the relevant inspection area.

Measurement results from vibration monitoring shall be followed up and acted upon by carrying out the necessary measures to prevent damage to surrounding structures.

During the contract period, the contractor shall inspect slopes with regard to surface and overall stability, as well as potential future issues with washouts, and specify measures to meet the necessary requirements. The client shall be given the opportunity to participate in inspections at least 3 working days in advance. Inspections shall be carried out through

Created by
[Created by]
Case number
[Case number]

Document date
[Document date]

Confidentiality level
[Confidentiality level]

the presentation of stability calculations, grouting reports, rock clearance reports, inspection reports, surveying, and mapping of completed slopes.

Ongoing rock clearance and rock inspection, in the form of visual inspections, shall be carried out to ensure stability. Rock clearance work shall be documented with photographic records and rock clearance logs.

Documentation must be provided to the client on an ongoing basis.

Once the rock slope has been excavated, the contour shall be surveyed from the foot of the slope to the crest and photographed. Reinforcement measures carried out shall be listed with unique numbers, together with the surveyed location and current data on type, extent, length and material, to be included in the final documentation.

All rock mapping shall be carried out in accordance with TDOK 2023:0199 "Engineering Geological Mapping". Results shall be provided to the client no later than 24 hours after the mapping has been completed. Mapping shall be carried out by a rock expert.

DB53. Vegetation with plant beds

Requirements for vegetation and plant beds are set out in DB51. Slope

DB56. Fencing/Wildlife fencing

Scope

At km 77+350, the existing wildlife fence at the junction is directed towards the railway line in such a way that animals coming from the south can continue northwards, whilst animals from other directions are diverted away from the junction.

Function

Wildlife fencing shall be positioned so as not to create a disruptive impression in the road environment.

Wildlife fencing shall be positioned, and where necessary fitted with gates, so that bridges are accessible for inspection and maintenance.

Wildlife fencing adjacent to wildlife crossings should be designed to help guide animals towards the wildlife crossing.

Technical solution

Wildlife fencing is ordered as TGM material from Procurement and Logistics.

Wildlife fencing shall be of the mesh type with a mesh height of at least 2.1 m and a total height from the ground of at least 2.2 m. The distance between the lower edge of the mesh and the ground surface shall not exceed 0.1 m.

Wildlife fencing must be installed in accordance with the manufacturer's instructions.

Wire for wildlife fencing, mounting fittings and any additional wire must be made of metal and protected against corrosion by hot-dip galvanising or by other equivalent corrosion protection.

Wooden posts must be impregnated to wood protection class A in accordance with NTR Document No. 1:2011, Nordic Wood Protection Tolerances.

Created by
[Created by]
Case number
[Case number]

Document date
[Document date]

Confidentiality level
[Confidentiality level]

Posts must be designed and installed so that they can withstand a horizontal load of 200 N at 2 m above ground level without being damaged or suffering permanent deformation.

Braces and struts must have the same durability as specified for the posts. The distance between posts must not exceed 4 m.

Posts must be erected vertically with a deviation from the plumb line of no more than 1.5 degrees (0.05 m over 2 m).

The netting shall be positioned so that the vertical wires are parallel to the posts. The deviation must not exceed 4 degrees (0.15 m over 2 m).

The net must be mounted on the side of the post facing the terrain.

Where the tension in the net exerts a pulling force on the net's attachment, the net shall be mounted on the roadside of every 6th post

In the event of significant changes in direction, for example at 90-degree corners, the corner post must be braced and the mesh installed on the outside of the corner post.

The netting must cover both the lower part of the fence up to 0.6 m above ground level and the ground up to 0.7 m from the fence.

DB7. Drainage systems, etc.

Scope

Drainage comprises the drainage of the road structure, the collection and diversion of surface water and drainage water from the road structure and the road area, and the conveyance of flows through the road structure. Drainage of bridge structures is covered in Chapter G.

Function

The surface water system must be capable of conveying away and managing water from road surfaces, road structures and verges.

Pipes, culverts, drainage pipes and ditches shall be designed so that their function is maintained, taking into account the settlement, both total and differential, that occurs during the structure's service life.

The drainage of surface water from the road structure must take place without causing erosion that could damage the structure.

Road surface water shall primarily be drained via open, gravity-fed ditches. Covered pipes shall only be installed in exceptional cases where conditions for ditches are unfavourable. When ditches are constructed, the bottom of the ditch shall be positioned at least 0.3 metres below the road's surface level.

For road sections critical to maintaining railway operations, the following applies: A return period of at least 100 years shall be selected for design with regard to traffic disruption

Construction, design and dimensioning must comply with TRVINFRA 00231.

A heavy rainfall analysis using 2D hydraulic modelling shall be carried out where the railway passes through areas with a high proportion of impervious surfaces, locations that are difficult to assess, and road underpasses beneath the railway.

Created by
[Created by]
Case number
[Case number]

Document date
[Document date]

Confidentiality level
[Confidentiality level]

DB71. Drainage systems

Function

Drainage systems designed to drain contaminated areas on surrounding land must not be constructed in such a way that the contamination is spread as a result of the drainage system. DB71b. Drainage pipe

DB71b. Drainage pipe

Function

A drainage pipe shall be designed so that the drained water is collected and discharged in an efficient and safe manner. There shall be good hydraulic contact between the structure to be drained and the drainage pipe.

The pipe must meet the requirements for deformation and directional deviation in tolerance class A in accordance with Svenskt Vatten P91.

Technical solution

Drainage pipes shall have a smooth interior and be manufactured in straight lengths. Drainage pipes shall be positioned outside the edge of the paving.

At the outlet of the drainage system, a drain with a sand trap must be installed.

Inspection

Inspection of deformation and directional deviation shall be carried out in accordance with Svenskt Vatten P91.

DB72. Stormwater systems

Scope

The stormwater system shall drain the road area and all new roads and footpaths within the works area. The stormwater system shall ensure that:

- No damage occurs to the road structure from water.
- Water does not flow onto the carriageway,
- Watercourses do not constitute an ecological barrier,

The stormwater system must be marked and signposted so that operation and maintenance can be carried out without the need for specific location measures.

DB72b. Piping

Function

Stormwater pipes within or adjacent to railway lines must comply with the requirements of TDOK 2014:0945, Laying of pipes and pipe crossings within or adjacent to railway lines.

Gravity pipes shall have a minimum longitudinal gradient in accordance with *TRVINFRA-00231 Table 12-1*, taking into account self-cleaning. Gravity pipes that discharge only drainage water, not stormwater, are exempt from the minimum gradient requirements in *Table 12-1*. Gravity pipes that discharge only drainage water are subject to the same longitudinal gradient requirements as drainage pipes.

Created by
[Created by]
Case number
[Case number]

Document date
[Document date]

Confidentiality level
[Confidentiality level]

Pipes and culverts in a road structure shall be dimensioned so that their function can be maintained for at least 40 years with normal maintenance.

Pipes and culverts in a road structure with a fill height exceeding 5 m, as well as culverts carrying watercourses beneath a dual carriageway, shall be dimensioned so that their function can be maintained for at least 80 years with normal maintenance.

Pipes and culverts in close proximity to railway tracks shall be dimensioned so that their function is maintained for at least 80 years with normal maintenance if railway traffic is affected during maintenance of culverts and pipes.

DB72b. Pipe/Gravity pipe

Function

Stormwater pipes must not have a draining function.

Pipes shall meet the requirements for tightness, deformation and directional deviation in tolerance class A, in accordance with Svenskt Vatten P91.

Inspection

Inspection of watertightness, deformation and alignment deviation shall be carried out in accordance with Svenskt Vatten P91. The pipe shall be inspected using CCTV. Fault codes and grading shall comply with Svenskt Vatten P93.

DB73. Ditch

Scope

Refers to all roadside ditches within the work area.

Function

Open ditches shall be constructed where stability permits.

The discharge of ditches into natural watercourses must not cause turbidity.

Where there is a risk of erosion, the bottom and slopes of the ditch must be fitted with erosion protection. The erosion protection must be dimensioned in accordance with Geokonstruktion, Dimensionering och utformning.

The connection of the ditches to culverts shall be designed so that upstream damming cannot occur. Erosion protection shall be installed at the outlet of the ditch.

Technical solution

A ditch constructed for the purpose of draining the superstructure shall be designed so that the bottom of the ditch lies at least 0.30 m below the terrace surface.

DB73. Ditch/Cross-ditch

Scope

Refers to cross-drains for roads.

Technical solution

Created by
[Created by]
Case number
[Case number]

Document date
[Document date]

Confidentiality level
[Confidentiality level]

Cutting ditches shall be designed to be at least 0.5 m deep below the road edge. Where there is no drainage for the terrace, the bottom of the ditch shall be at least 0.3 m below the terrace level.

DB73. Ditch/ Embankment ditch

Function

A road verge ditch is provided to prevent harmful water accumulation and to stop water from a road flowing onto adjacent land.

The embankment ditch should normally be located 0–2 m from the foot of the embankment.

DB74. Culvert

Scope

The scope is investigated and coordinated with the client. Previous investigations indicate a need for culverts, and these are detailed in OLP3-51-025-33-0_0-0210 and OLP3-51-025-32-0_0-0210 (Design Memorandum on drainage).

Function

Culverts (both external and internal) shall be coloured so that they blend in visually with the surroundings.

Technical solution

The culvert must meet the requirements for deformation and alignment deviation in tolerance class A, in accordance with Svenskt Vatten P91.

Inspection

Inspection of deformation and directional deviation shall be carried out in accordance with Svenskt Vatten P91.

DC. Road safety barrier

DC1. Guardrail

Function

A guardrail shall be installed in such a way that it acquires and retains the properties determined during type testing.

The strength of bituminous material must not be relied upon to withstand long-term loads, such as those from prestressing forces in steel cables.

Where standard foundation methods cannot be used, e.g. due to sensitive equipment in the ground or the installation of a road guardrail on a bridge deck, foundation and fixing elements adapted for the guardrail shall be used.

Foundations shall be constructed so that they do not move, crack or deform in the event of a collision with the guardrail, as determined by the capacity class test, and can be reused without special measures.

Foundations shall be designed so that they do not deform or shift under long-term loads from prestressed guardrails.

Created by
[Created by]
Case number
[Case number]

Document date
[Document date]

Confidentiality level
[Confidentiality level]

Foundations shall be constructed so that railing posts are not torn from the foundation in the event of an impact corresponding to the capacity class determination test.

The connection between the handrail posts and the foundations must be designed to prevent material from penetrating the foundations.

Technical solution

When installing a protective device with slabs laid in the ground, the following shall apply:

- The protective device shall be bolted to the foundation structure
- The base structure and foundations shall be dimensioned in accordance with SS-EN 1991-2, 4.7.3.3(2).

The foundation must be installed with the upper part slightly above the surrounding ground or road surface, but no more than 0.1 m above the surface.

Installation must be carried out in accordance with the manufacturer's installation instructions. The person responsible for site management and supervision must:

- Be available during the installation work
- Have documented theoretical knowledge and practical experience regarding materials, installation and inspection of safety devices equivalent to that of an authorised railing installer certified by the Swedish Road and Bridge Railing Association (SVBRF)
- Have knowledge of the structure and function of the relevant device

Technical solution/Materials, Steel

All steel parts in the guardrail, which are not made of stainless steel, shall be hot-dip galvanised in accordance with at least Table NA.1, Fe/Zn 115 in SS-EN ISO 1461. Exceptions are washers, which must be hot-dip galvanised in accordance with Table 3 of SS-EN ISO 1461, and bolts and nuts, which must be hot-dip galvanised in accordance with SS-EN ISO 10684.

Steel embedded in concrete or rock shall be hot-dip galvanised in accordance with Table NA.1, Fe/Zn 115 in SS-EN ISO 1461, up to the greater of the thickness of the coating or 50 mm.

Cables for steel cable railings shall be hot-dip galvanised in accordance with ASTM A741 Class B. Zinc for hot-dip galvanising shall meet the requirements of SS-EN 1179 with a maximum of 5 per cent aluminium content (Zn95Al5).

Technical solution/Material, Aluminium

For railings in marine and road environments, alloys in durability class A in accordance with SS-EN 1999-1-1 are acceptable.

Technical solution/Materials, Fasteners Screws shall be marked in accordance with SS-EN ISO 898-1. **Technical**

solution/Materials, Concrete

Concrete shall meet the requirements for exposure class XD3/XF4 in accordance with SS-EN 206 and SS 137003. The service life class shall be 50 years.

Created by
[Created by]
Case number
[Case number]

Document date
[Document date]

Confidentiality level
[Confidentiality level]

The covering concrete layer shall meet the requirements for exposure class XD3 in accordance with EKS 10, Chapter 2.1.1. The service life class shall be 50 years.

Inspection

The site management appointed for the railing installation must, upon completion of the installation, notify the client in writing that the railing has been installed in accordance with the manufacturer's installation instructions.

Inspection/Products subject to CE marking requirements

The manufacturer/supplier shall provide:

- Certificate of Constancy of Performance
- Declaration of Performance
- Installation instructions, including information on maintenance and inspection in accordance with Chapter 8 of SS-EN 1317-5
- Information relevant to durability (corrosion protection, surface treatment and the like) in accordance with Chapter 4 of SS-EN 1317-5
- Information on the product and its use in accordance with Chapter 5 of SS-EN 1317-5. The

documentation in accordance with Chapter 8 of SS-EN 1317-5 must be written in Swedish.

Once installation is complete, products must be marked in accordance with SVBRF's "Instructions for the physical marking of vehicle safety devices". See the SVBRF website.

Inspection/Other products

The manufacturer shall verify that requirements regarding materials, workmanship, testing and inspection are met. The verification report shall, where applicable, be drawn up in accordance with SS-EN ISO/IEC 17050-1.

The manufacturer/supplier shall provide:

- Installation instructions, including information on inspection, maintenance, testing and repair
- Information relevant to durability (corrosion protection, coatings and the like)
- Information about the product and its use The

documentation must be written in Swedish.

For products whose performance is not demonstrated by crash tests, calculations and supporting documentation demonstrating compliance with requirements for strength and design must be provided.

DC1. Guardrail/Road barrier

Technical solution

The guardrail must be installed with tolerances in accordance with the supplier's instructions; however, the vertical tolerance must be within the range of -0.01 m to +0.05 m. Upon completion of installation, the guardrail must be aligned with a straight line, and any deviation must not be visible upon visual inspection.

Created by
[Created by]
Case number
[Case number]

Document date
[Document date]

Confidentiality level
[Confidentiality level]

Where stainless steel and galvanised materials are used together, the threads and other contact surfaces must be lubricated during installation with a suitable, highly durable lubricant.

Hollow foundations and anchors with an upper surface at ground level and an internal diameter exceeding 70 mm shall be filled or sealed with a cover made of durable material. Covers shall be designed so that they do not come loose under normal operating conditions.

At least one part of the threaded component (nut or threaded rod) used for splicing, anchoring and tensioning steel cable railings shall be made of stainless steel grade 1.4301 (AISI 304) in accordance with SS-EN 10088-3.

DC1. Guardrail/ Road guardrail// KM 80+790

Function

A road guardrail is to be installed on one side of the road, at km 80+790 (elevation of the road on the bridge over the railway), if the embankment on one side exceeds 4 m.

DC1. Guardrail/Bridge guardrail

Scope

Bridge railings shall be installed on the road bridge and supporting structure with a kerb beam along the carriageway.

Function

Bridge railings shall meet the requirements set out in "Requirements for Bridges and Bridge-like Structures".

Technical solution

Screws, nuts and washers for securing the railing to the bridge shall be made of stainless steel with good corrosion resistance. Grades 1.4401, 1.4404, 1.4406, 1.4429, 1.4432, 1.4435, 1.4436, 1.4438 and 1.4462 in accordance with SS-EN 10088-1 through to SS-EN 10088-5 are considered to meet the specified requirements.

The railing shall be installed with tolerances in accordance with the supplier's instructions; however, the vertical tolerance must not exceed ± 0.02 m and the lateral tolerance must not exceed ± 0.02 m. Upon completion of installation, the railing shall be aligned with a straight line and any deviation must not be visible upon visual inspection.

Inspection

Guardrails along carriageways on road bridges shall be certified in accordance with SS-EN 1317-5 with regard to capacity class, standardised working width, dynamic deflection, risk of injury class and durability, as well as, where applicable, vehicle penetration and resistance to snow ploughing.

DC11. Guardrail termination

Function

Guardrail terminations in the central reservation must be clearly indicated to road users by means of marker posts or similar.

Guardrail terminations that also serve as anchors for connecting guardrails shall meet the requirements for permitted movement in accordance with SS-EN 1317-2 Annex B for the tested guardrail length.

For guardrail terminations not used in the type testing of the connecting guardrail, the supplier must demonstrate that the requirements for permitted movement, in accordance with SS-EN 1317-2 Annex B, are met.

DC14. Transition between handrails

Created by
[Created by]
Case number
[Case number]

Document date
[Document date]

Confidentiality level
[Confidentiality level]

Function

A transition between different railings shall equalise capacity and deformation properties so that the likelihood of, for example, pocket formation and damage caused by sudden variations is minimised. It shall also be capable of transferring any loads that occur.

The tensile strength of a connecting element shall be greater than that of the weakest connection in the adjoining guardrails.

Verification

For transitions and connecting elements between railings, design and calculation documentation must be provided.

DC16. Railing completion/Suicide protection

Scope as per Table (DC16).1

Table (DC61).1 Scope of suicide protection for road bridges

City centre bridge at km (1)	Location	Need for protection
69+012	New road bridge over railway (Road 608)	Yes, protection over railway
80+788	New road bridge over railway (Road 531)	Yes, protection over railway
84+212	New road bridge over railway (Eriksgatan)	Yes, protection over railway
87+794	New road bridge over railway	Yes, protection over railway

Function

Suicide protection shall be designed as a combination of guardrail, suicide protection and electrical protection, forming a unified whole with a sleek and light appearance.

For road bridges over railways, a combined vehicle restraint system and suicide prevention barrier in accordance with point two of K135258 in TRVINFRA-00227 "Bridges and bridge-like structures, Construction" shall be used.

Technical solution

The embedment length for railing posts or threaded rods shall be at least 100 mm. Suicide protection shall have an effective height of 2 m and be angled outwards as shown in Figure (DC16).2.

Created by
[Created by]
Case number
[Case number]

Document date
[Document date]

Confidentiality level
[Confidentiality level]

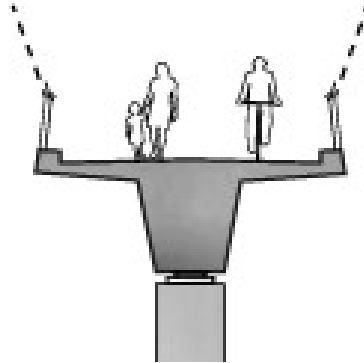

Figure (DC16).2. Bridge with outward-angled suicide protection.

Created by
[Created by]
Case number
[Case number]

Document date
[Document date]

Confidentiality level
[Confidentiality level]

DD. Road signs, road markings and roadside markings

DD1. Road signs

Function

General signage within the relevant work area shall be implemented in accordance with the principles set out in the project's signage plan.

Traffic control devices located within the safety zone and not protected by a guardrail or equivalent shall be impact-absorbing.

Road sign devices shall be marked in accordance with SS-EN 12899-1.

Road signs shall be angled and reflective in such a way that they are clearly visible and do not dazzle road users.

Road signs must not be obscured by lighting fixtures or similar.

Road signs, including supports and foundations, shall meet requirements for load-bearing capacity, stability and durability under the specified conditions prevailing at the site.

Service roads must not be equipped with road signs or markings that lead to, or otherwise indicate, the location of tunnels, alternative entrances and/or exits, and tunnel mouths.

Technical solution / Materials / Steel

- All steel components that are not made of stainless steel shall be hot-dip galvanised in accordance with at least SS-EN ISO 1461, Table NA.1, Fe/Zn 115, with the following exceptions:
- steel washers shall be hot-dip galvanised in accordance with at least SS-EN ISO 1461, Table 3
- threaded structural elements shall be hot-dip galvanised in accordance with SS-EN ISO 10684
- road sign tubes with a diameter of 108 mm or less shall be hot-dip galvanised in accordance with SS-EN 10240, class A1B1, or in accordance with SS-EN ISO 1461, Table 3.

During processing, damaged corrosion protection shall be repaired in accordance with SS-EN ISO 1461, Section 6.3 and Annex C.

Technical solution/ Materials/ Aluminium

Structural components made of aluminium above ground level shall be manufactured from alloys that meet the requirements for durability class A or B in accordance with SS-EN 1999-1-1, Table 3.1a.

Structural components made of materials in durability class B shall be anodised to at least class AA20 or be painted. The oxide layer shall be resealed.

Aluminium structural components in the ground or in foundations shall be surface-treated with an electrically insulating two-component paint system intended for use in corrosivity class C5-M or higher in accordance with SS-EN ISO 12944-5. The paint coating shall be at least 240 µm thick, applied in at least two layers, and extend at least 0.5 m above the ground or foundation surface.

Technical solution/ Materials/ Concrete

Concrete shall meet the requirements for exposure class XD3/XF4 in accordance with SS-EN 206-1 and SS 137003. The service life class shall be 50 years.

Created by
[Created by]
Case number
[Case number]

Document date
[Document date]

Confidentiality level
[Confidentiality level]

The covering concrete layer shall meet the requirements for exposure class XD3 in accordance with SS 137010. The service life class shall be 50 years.

Technical solution

Road signs must be installed in straight lines, both vertically and horizontally.

Ground-mounted road signs shall be installed vertically; the inclination must not exceed 1° relative to the vertical. Lane direction signs in gantries shall be installed with the lower edge horizontal.

Inspection

Poles with signs for road signs, including fixings and retro-reflective sheeting, shall be declared in accordance with SS-EN 12899-1 Table ZA.6 and marked in accordance with SS-EN 12899-1 Section 9.

Reflective sheeting may alternatively be declared in accordance with the ETA (European Technical Assessment) based on EAD 120001-00-0106 (Microprismatic retro-reflective sheeting) and classified in accordance with DIN 67520, DIN 6171-1 or SS-EN 12899-1.

Once installation is complete, products must be physically marked with the CE mark. The CE mark must be permanently affixed and fully legible until the end of the warranty period. The CE mark must be placed on the back of the sign as follows:

- on location markers on the lower right-hand edge
- on other road signs in the right-hand part of the road sign.

The manufacturer/supplier must provide a CE certificate, a declaration of performance and installation instructions, including information on maintenance and care.

The documentation must be written in Swedish.

DD1. Road sign/Standard road sign

Scope

The requirements apply to ground-mounted standard road signs with a maximum width of 1.8 metres.

Function

Signs with associated fixings and supports shall be dimensioned with regard to load-bearing capacity, stability and durability under the conditions prevailing at the site, whereby dead weight, wind load, snow load and environmental aggressiveness shall be taken into particular account.

Safety class 1 shall be used for road signs.

For standard road signs, safety factor PAF1 in accordance with SS-EN 12899-1:2007 may be used. For standard road signs, wind pressure class WL6 in accordance with SS-EN 12899-1:2007 shall be used. For standard road signs, snow plough class DSL2 in accordance with SS-EN 12899-1:2007 shall be used. Wind and snow plough loads need not be combined.

Signs with associated fixings and supports shall, with regard to temporary deflections and torsions, at least meet the requirements for classes TDB4 and TBT4 respectively, in accordance with SS-EN 12899-1:2007, section 5.4.

Created by
[Created by]
Case number
[Case number]

Document date
[Document date]

Confidentiality level
[Confidentiality level]

For fixed road signs with a sign area of less than 0.7 m² mounted with the top edge of the sign a maximum of 3.5 m above ground level, steel tube supports with a characteristic strength of at least 235 MPa, an outer diameter of at least Ø 60 mm and a wall thickness of at least 2.25 mm are acceptable without specific design for wind or ploughed snow loads.

Technical solution

The top of the tubular post shall be fitted with a corrosion-protected, watertight cap.

DD1. Road sign/Standard road sign

Scope

The requirements apply to ground-mounted standard road signs with a maximum width of 1.8 metres.

Function

Signs, including associated fixings and supports, shall be dimensioned with regard to load-bearing capacity, stability and durability under the conditions prevailing at the site, with particular consideration given to dead weight, wind load, snow load and the aggressiveness of the environment.

Safety class 1 shall be used for road signs.

For standard road signs, safety factor PAF1 in accordance with SS-EN 12899-1:2007 may be used. For standard road signs, wind pressure class WL6 in accordance with SS-EN 12899-1:2007 shall be used. For standard road signs, snow plough class DSL2 in accordance with SS-EN 12899-1:2007 shall be used. Wind and snow plough loads need not be combined.

Signs with associated fixings and supports shall, with regard to temporary deflections and torsions, at least meet the requirements for classes TDB4 and TBT4 respectively, in accordance with SS-EN 12899-1, section 5.4.

For fixed road signs with a sign area of less than 0.7 m² mounted with the top edge of the sign a maximum of 3.5 m above ground level, steel tube supports with a characteristic strength of at least 235 MPa, an outer diameter of at least Ø 60 mm and a wall thickness of at least 2.25 mm are acceptable without specific design for wind or snowplough loads.

Technical solution

The top of the tubular post shall be fitted with a corrosion-protected, watertight cap.

DD1. Road sign / Non-standard road sign DD11.

Sign

Function

The back of the sign must not be so glossy that it causes distracting reflections.

Signs for road signs must meet the requirements for class P3 in accordance with SS-EN 12899-1:2007 regarding perforation.

Function/ Reflective material

Within the same set, reflective materials with different properties must not be mixed; the road sign with the highest requirements dictates the requirements for other signs, including supplementary signs. This shall also apply when supplementing existing road signs, e.g. when the road number is changed on a location sign.

Created by
[Created by]
Case number
[Case number]

Document date
[Document date]

Confidentiality level
[Confidentiality level]

DD2. Road Markings

Function

Road markings must be designed in accordance with the Road Signs Ordinance (SFS 2007:90), the Swedish Transport Agency's regulations (TSFS 2010:171) on road markings, and section 13.2 of "Requirements – VGU".

Road markings shall be white and meet the colour requirements in accordance with SS-EN 1436:2007.

Glass beads for road markings shall meet at least the requirements for Class A regarding refractive index, in accordance with SS-EN 1423:2012 Amendment: SS-EN 1423/A1.

Road markings shall be designed so as not to cause problems with water accumulation on the road surface. The difference in level between the pavement and the upper surface of the marking shall not exceed 4 mm.

Under dry conditions, road markings shall meet the following technical performance requirements in accordance with SS-EN 1436:2007.

- Longitudinal road markings shall meet the following requirements:
- retro-reflectivity, $RL \geq 150$
- luminance coefficient, $Q_d \geq 130$
- friction, SRT (PFT) ≥ 50 (0.55).

In addition, longitudinal lines on roads with an AADT $\geq 2,000$ must meet the requirements for retroreflection in wet conditions, $RW \geq 35$, with the exception of:

- lane lines
- road markings on roads with a speed limit of 60 km/h or less
- roads with continuous lighting on stretches longer than 2 km.

Longitudinal road markings must have a 100 per cent white surface when viewed directly from above, with the exception of solid edge lines, which must meet retroreflectivity requirements in wet conditions and have at least 60 per cent of their surface evenly distributed in white.

Transverse road markings shall meet the following requirements:

- retro-reflectivity, $RL \geq 100$
- luminance coefficient, $Q_d \geq 130$
- friction, SRT (PFT) ≥ 55 (0.58).

Other road markings must meet the following requirements:

- retro-reflectivity, $RL \geq 100$
- luminance coefficient, $Q_d \geq 130$
- friction, SRT (PFT) ≥ 50 (0.55).

Road and surface markings must not be used until they are ready for traffic.

Created by
[Created by]
Case number
[Case number]

Document date
[Document date]

Confidentiality level
[Confidentiality level]

Requirements for yellow road markings:

- retro-reflectivity, $RL \geq 150$
- luminance coefficient, $Q_d \geq 100$
- friction SRT (PFT) ≥ 50 (0.50)
- colour in accordance with SS-EN 1436:2007 and NTY (Night Time Yellow) in accordance with ASTM D6628.

Technical solution

The specified tolerances refer to individual measured values for longitudinal road markings and for the spacing between lines.

Road markings with line lengths and spacing:

- less than or equal to 3 m may deviate by a maximum of ± 0.05 m in the longitudinal direction
- more than 3 m may deviate by a maximum of ± 0.10 m in

the longitudinal direction. Road markings with line width and spacing:

- 0.10 m may deviate by a maximum of ± 0.005 m in the transverse direction
- 0.15 m and 0.20 m may deviate by a maximum of ± 0.010 m in the transverse direction
- 0.30 m may deviate by a maximum of ± 0.015 m in the transverse direction.

When applying longitudinal road markings, a compact 3-line system shall be used; see Figure AMA DEE.1/1 in AMA Anläggning.

Inspection

Inspection of longitudinal markings shall be carried out using mobile equipment in accordance with the method description "TDOK 2013:0461". Inspection of longitudinal features shorter than 1 km may alternatively be carried out using a hand-held instrument in accordance with "TDOK 2013:0462".

Transverse and other markings shall be checked using a handheld instrument in accordance with "TDOK 2013:0462".

DD23. Noise rumble strips

Technical solution

~~Surfaces where grooving has been carried out must be sealed in their entirety after milling.~~

~~The milled surface must be cleaned and free of loose particles before sealing is carried out.~~

~~Sealing shall be carried out using bitumen emulsion C 50 B 2 – 160/220. The emulsion shall comply with the current specifications in Bitumen-bound layers, TDOK 2013:0529, Table 2.2.4-1.~~

~~Sealing must be carried out at a rate of 0.4 kg/m² and the entire milled surface must be covered with bitumen emulsion.~~

Created by
[Created by]
Case number
[Case number]

Document date
[Document date]

Confidentiality level
[Confidentiality level]

If excess binder occurs which is deemed to pose a slip hazard, the surface must be sanded with 2/4 mm aggregate.

DJ. Passage for wildlife, etc.

Scope

Railway bridge at km 65+507 over wildlife crossing and minor road,
Railway bridge km 70+251 over wildlife crossing and watercourse, railway
bridge km 75+681 over wildlife crossing and minor road, railway bridge
km 79+950 over wildlife crossing and watercourse, railway bridge km
90+300 over wildlife crossing,

Function

Combined service road and wildlife crossing shall be constructed using natural materials as the wearing course; crushed aggregate must not be used.

Wildlife crossings for large game must have a clearance height of four metres and a clear opening of 12 metres. Wildlife crossings for small game must have a clear width and a clearance height of at least 0.6 m.

Wildlife passages must not be designed in such a way that they become waterlogged. The beach passage must be dry and lie above the mean high-water level. Connections to the natural beach must be constructed so that they cannot be flooded.

The original shoreline must be preserved and the beach crossing must be adapted to the existing shoreline.

The beach passage must be equipped with marker stones that are at least 0.2 m in diameter. Marker stones must be placed in such a way that there is a clear path to walk on alongside the stone.

The vegetation on and adjacent to a beach access path must blend in with the natural vegetation along the watercourse in question.

Crushed material must not be present on a beach access.

Created by
[Created by]
Case number
[Case number]

Document date
[Document date]

Confidentiality level
[Confidentiality level]

F. RAILWAY

Although the railway plan, design and specified requirements constrain parts of the design, there is scope to jointly find cost-effective solutions. The contractor and the client shall, through cooperation, identify and develop solutions that contribute to increased efficiency and value for the project.

The works must meet the requirements of the TSD Infrastructure TSD line category P2 (TRV 2025/8145).

- Reference profile GC and SEa.
- The maximum permitted speed (STH) for all train categories ERTMS 1–10 is 250 km/h on double tracks.

The maximum permissible axle load (STAX) is:

- 25 tonnes at STH 100 km/h.
- 22.5 tonnes at STH 200 km/h.
- 20 tonnes at STH 250 km/h.

Maximum permissible weight per metre (STVM) for geostructures: 8 tonnes/m.

Maximum permissible weight per metre (MPWM) of track: 6 tonnes/m.

The longest train for which the line is designed is 550 metres.

Maximum gradient is 25‰. Technical

headway 2.5 minutes *Table (F). 1. Rail traffic.*

Type	Number during peak hour (trains/hour)	Number per day (trains/day)	Maximum train weight (tonnes)
Passenger trains		150	550

Scope

The Ålberga contract (Skavsta–Stavsjö section) covers the two main tracks belonging to the East Link/main line.

In addition to the general interfaces mentioned above, there are also technology-specific interfaces. This means that connections to technical buildings, ducting, catenary systems, etc. are carried out outside the kilometre points specified in Chapter A, Scope/General Description.

Scope/BEST-K

The contractor shall carry out the BEST installation and ducting in accordance with the documents provided by the client. The main work is carried out within the boundaries of the contract. However, there are EST system interfaces that extend beyond these boundaries and are included in the contract.

Created by
[Created by]
Case number
[Case number]

Document date
[Document date]

Confidentiality level
[Confidentiality level]

The final scope regarding BEST-K is set out in the client's design. For a rough overview of the scope of work, the following applies:

- Wiring diagram Ålberga TLS4110-68-885_68-30-0_0-0001.
- Master plan TLS4110-01-170-00000-62_93-013-017.

Function/locks

Cliq locks are to be fitted to cabinets, gates, etc. where intrusion protection is required. Documentation of location and lock numbers is included. Locks are supplied.

Technical solution/Track design/Length measurement

The track used for distance measurement is track N, and the distance measurement specifications are based on OLP3's distance measurement.

Please note that distance measurement in OLP3 (which covers the Ålberga contract) is designed in SWEREF 99 16 30.

FB. Embankment construction

Scope

Embankment construction for permanent tracks is to be carried out from km approx. 63+300 to km 91+275 in accordance with the designed track layout.

Embankment construction is defined in accordance with the Appendix: Standard Cross-Sections (Appendix X)

Technical solution

For excavation and embankment construction on the "Ostlänken" Main Line, Standard Section Appendix X applies

The shoulder width b_v and b_h in TDOK 2015:0198 shall be 3.7 m

Inspection

Surveying and registration of FOMUL objects must be carried out before the facility is put into service TRVINFRA-00398 "Track and Station Design" Section 9 Measurement of FOMUL and track spacing demonstrating that no objects encroach on the standard clearance section.

Monitoring of subsidence of the subgrade and embankment body in accordance with Chapter F, codes Fb1, Fb2, Fb3 and Fb4, is verified by track position measurement. Inspection is carried out by monitoring that the track position remains within established limit values.

Measurement of limit values for deviations shall be carried out in accordance with TRVINFRA 00013 "Track Alignment" and shall cover track alignment, vertical alignment, lateral alignment, rail elevation and skew.

Specified limit values:

Total settlement must not result in the limit values specified below being exceeded for the respective time periods.

Created by
[Created by]
Case number
[Case number]

Document date
[Document date]

Confidentiality level
[Confidentiality level]

1. After 0–6 months, the limit value for deviations must not exceed the PLAN level.
2. After 6–18 months, the limit value for deviations must not exceed level PLAN.
3. After 18–60 months, the limit value for deviations must not exceed level UH1.

FB1. Track superstructure

Scope

It is part of the TLS contractor's undertaking to carry out and construct the track superstructure in accordance with the construction specifications and the technical solution consisting of construction documents supplied by the client's consultant.

Technical solution

New track shall be constructed as ballasted jointless track. The section in question shall have inspection class B4.

Standard main track shall be constructed to speed class H5.

Continuous welded track shall be designed and constructed in accordance with TRVINFRA-00012 "Track Systems".

For track laid on bridges with continuous ballast, the geometric design of the track and the dimensioning and construction of the track superstructure shall comply with TRVINFRA-00012 "Track Systems" and TRVINFRA-00398 "Track and Station Design", Section 5 Track Geometry and [Annex X](#).

Preventive track grinding shall be carried out prior to commissioning of the facility

New materials shall be used in new construction. New track shall be constructed using new materials.

Inspection

For ballasted track, tolerances for the absolute position of the track apply in accordance with TRVINFRA-00398 "Track and Station Design", Section 5 Track Geometry.

FB2. Sub-ballast

Function

The sub-grade shall be frost-free where geotechnical investigations show that the sub-grade or underlying soil down to the frost-free depth consists of soil in frost susceptibility classes 2–4.

For each type of sub-ballast, there must be a continuous length of at least 200 m along the track. Along the entire length, changes in sub-ballast type must not be made transversely.

Technical solution

The surface shall be constructed with a height tolerance of +/- 20 mm. A homogeneous layer shall be achieved along the entire length.

Created by
[Created by]
Case number
[Case number]

Document date
[Document date]

Confidentiality level
[Confidentiality level]

Modulus of elasticity = 50 MPa. Angle of friction = 45°.

Sub-ballast of different material types (crushed material, soil) must not be mixed.

Must consist of at least 0.8 m of sub-base for reinforcement in accordance with the requirements in “AMA Anläggning” DCH.15. The sub-base must be constructed in two layers in accordance with Figure RA DCH.1/1 when the terrace and underlying soil consist of frost susceptibility classes 2, 3 or 4 according to Table AMA DC/1.

Sub-base shall be constructed in a single layer with a minimum thickness of 0.8 m where the terrace and underlying soil consist of soil in frost heave class 1 in accordance with AMA DC/1.

For terrace surfaces consisting of rock or soil of material type 2, the thickness may be reduced to 0.5 m. Material type according to “AMA Construction” Table DC/1.

The grading coefficient must be greater than 6.

Levelling of differences in level between different material types in the longitudinal direction must be carried out with a maximum gradient of 5 per cent

Residual products or organic material must not be present in the finished layer.

Inspection/Materials and goods

Inspection of materials for sub-base layers shall be tested in accordance with TDOK 2014:0145 – “Determination of particle size distribution for coarse-grained materials by sieve analysis” v 1.0.

Inspection/Sampling

Samples shall be taken from laid, sample-crushed or crushed material from production. Samples shall not be taken by laboratory crushing.

Sampling of material for sub-ballast layers shall be carried out in accordance with TDOK 2014:0151 – “Sampling of unbound materials” v 1.0.

FB21. Reinforcement layer

Technical solution

Reinforcement layers shall consist of crushed rock material that meets the requirements of “AMA Anläggning” DCH.15.

The following text is omitted from AMA:

“The proportion of rock type 1 material...must not exceed MDE15.”

The text is replaced by:

Resistance to fragmentation and abrasion shall be determined for the 10–14 mm fraction. Resistance to fragmentation, LA, in accordance with SS-EN 1097-2 must not exceed 35.

Resistance to abrasion, MDE, in accordance with SS-EN 1097-1 must not exceed 15.

Inspection/Check of stock levels

The text under AMA construction code DCH.15 applies with the following additions:

Created by
[Created by]
Case number
[Case number]

Document date
[Document date]

Confidentiality level
[Confidentiality level]

Inspection of the level of sub-ballast shall be carried out in accordance with Table TRV DCH.15/1.

The surface shall be divided into inspection areas in such a way that it is covered in its entirety by inspection areas. Within an inspection area, the thickness of the bedding must not be altered.

Checks must not be carried out on frozen structures.

Measurements shall be carried out in accordance with TDOK 2013:0530 "Unbound layers for road structures", Section 12.

Kontrollobjekt	Lageryta $\leq 2500 \text{ m}^2$ Samtliga kontrollobjekt ska kontrolleras
Stickprov	Kontrollpunkter ska väljas med slumpmässigt urval inom kontrollobjektets yta enligt VVMB 908. $\leq 200 \text{ m}^2$ $n \geq 16$ $201-1200 \text{ m}^2$ $n \geq 24$ $1201-2500 \text{ m}^2$ $n \geq 32$ n = antal kontrollpunkter. Om mätresultaten visar små variationer och inga kontrollobjekt underkänns kan stickprovsantalet minskas till 16. När ett kontrollobjekt underkänns ska n återgå till stickprovskontrollen enligt ovan.
Mätförfarande	Enligt TDOK 2013:0530, avsnitt 12.
Mätvariabel	Vertikal avvikelser från riktvärde för nivå (mm).
Grovt fel	Grovt fel om enskild avvikelse $x_i > G_f $
Kriterievariabler	s = standardavvikelse \bar{x} = medelvärde x_i = enskilt värde

Created by
[Created by]
Case number
[Case number]

Document date
[Document date]

Confidentiality level
[Confidentiality level]

Kontrollobjekt	Lageryta $\leq 2500 \text{ m}^2$ Samtliga kontrollobjekt ska kontrolleras
Stickprov	Kontrollpunkter ska väljas med slumpmässigt urval inom kontrollobjektets yta enligt VVMB 908. $\leq 200 \text{ m}^2$ $n \geq 16$ $201-1200 \text{ m}^2$ $n \geq 24$ $1201-2500 \text{ m}^2$ $n \geq 32$ n = antal kontrollpunkter. Om mätresultaten visar små variationer och inga kontrollobjekt underkänns kan stickprovsantalet minskas till 16. När ett kontrollobjekt underkänns ska n återgå till stickprovskontrollen enligt ovan.
Mätförfarande	Enligt TDOK 2013:0530, avsnitt 12.
Mätvariabel	Vertikal avvikelse från riktvärde för nivå (mm).
Grovt fel	Grovt fel om enskild avvikelse $x_i > G_f $
Kriterievariabler	s = standardavvikelse \bar{x} = medelvärde x_i = enskilt värde

Table TRV DCH.15/1 level inspection.

The level inspection shall meet the requirements set out in Table TRV DCH.15/2. Inspection items that fail the test shall be rectified and then re-inspected.

Acceptansintervall	$s \leq 14$ \bar{x} inom $0 \pm (14 - 0,30s)$ mm G_f om $ x_i > 30$ mm (grovt fel)
Acceptansintervall	$s \leq 14$ \bar{x} inom $0 \pm (14 - 0,30s)$ mm G_f om $ x_i > 30$ mm (grovt fel)

Table TRV DCH.15/2 Level requirements for sub-base

FB22. Frost insulation layer

Technical solution

The frost insulation layer shall consist of:

Created by
[Created by]
Case number
[Case number]

Document date
[Document date]

Confidentiality level
[Confidentiality level]

- Crushed rock material that meets the requirements in accordance with “AMA Anläggning” DCH.16.
- Soil or crushed gravel material that meets the requirements of “AMA Anläggning” DCH.16.

FB3. Sub-base/Bank fill

Technical solution

The scope of the assignment includes identifying the most economically advantageous technical solution regarding sub-base/embankment fill in accordance with applicable requirements and regulations.

All embankment material shall be compacted in accordance with AMA Construction 20. The upper limit for stone size for embankment fill in accordance with AMA Construction CEB.31 is 500 mm, but no more than half the layer thickness after compaction.

Earth embankments must not be used within a distance of approximately 50 m from bridge abutments.

At transitions to bridges, a transition structure in the track substructure shall be constructed behind the bridge abutments; see Chapter GJ. Transition Structure.

On rock embankments, an internal structural slope with a gradient of 1:1.5 shall be constructed, and on top of this slope, soil of material type 2, 3B or 4A with a gradient of 1:2 shall be placed. Terraces on rock embankments shall be constructed without cross-slope.

FB4. Subgrade

Function

Ground reinforcement shall be carried out in accordance with TRVINFRA-00230 “Geostructures, Design and Layout” and TRVINFRA-00229 “Geostructures, Administrative Rules”.

Railway structures passing through wetlands shall be constructed to be permeable

Foundations for geotechnical structures shall be dimensioned for a cold load corresponding to a 100-year return period.

The cold loads specified in Table FB4.1 shall be assumed to apply to the midpoint between the specified locations.

Table FB4.1 Cold load (negative degree days, [°Cd])

Ort	Köldmängd (negativa graddygner [°Cd])
Stockholm	600
Järna	620
Norrköping	640
Linköping	650
Jönköping	610
Bottnaryd	700
Borås	680
Göteborg	440
Värnamo	680
Hässleholm	430
Malmö	280

The superstructure and frost insulation layer shall be designed so that the terrace surface is not exposed to frost with a return period of at least 100 years.

Created by
[Created by]
Case number
[Case number]

Document date
[Document date]

Confidentiality level
[Confidentiality level]

Filling must not be laid on a frozen terrace.

Function/Track vibrations

Unacceptable track movements caused by vibrations generated by trains on a track laid on reinforced or unreinforced subgrade must not occur. Permissible vertical displacement at the bottom of the sleeper due to train passage at speeds up to and including 250 km/h must not exceed 2 mm (peak-to-peak value).

For areas where $STH > c_s$, empiricism/1.5, the soil properties for geodynamic analyses shall be determined by measured values in the field in accordance with ISO/TS 14837–32:2015.

Where there is a risk of high-speed problems in unreinforced soil in accordance with TRVINFRA-00230 “Geotechnical Engineering, Design and Layout”, Chapter 6.2.7.2.3, dynamic analyses shall be carried out at STH 250 with an axle load of 20 tonnes and a speed of 250 km/h. Unless otherwise specified, when simulating moving loads, a train set in accordance with HSLM-A1 and Table 6.3 of SS-EN 1991–2 with an axle load of 20.0 tonnes and a speed equal to STH shall be used.

For investigation levels B2 and B3 in accordance with TRVINFRA-00230 “Geotechnical Engineering, Design and Layout”, Table K6.2–9, vibrations during train passage shall be calculated using numerical modelling.

When calculating using numerical modelling, the size of the model shall be determined so that the calculated vibrations within a distance of at least 10 m from the embankment foot are not affected by the model’s boundary conditions.

Numerical models used to calculate vibrations from rail traffic must have been validated using vibration measurements or results from another calculation model developed independently of the model in question.

When comparing model results with calculation results from another calculation model, C_d shall be limited to 0.6 and 0.65 for investigation levels B2 and B3 respectively, in accordance with TRVINFRA-00230 “Geotechnical Engineering, Design and Layout”, Chapter 6.2.7.2.3.2, Table K6.2–10. The C_d factor may be increased if a detailed 3D analysis with relevant train sets shows limited deformations < 2 mm. The determination of C_d shall be carried out in consultation with the client.

Technical solution/Ground reinforcement

A summary of derived values and selected characteristic values on which the ground reinforcement is based during the system design phase will be provided after the contract has been signed.

Backfilling following mass replacement beneath railway embankments shall be carried out using crushed rock with the same properties as the embankment material for railway embankments. Mass replacement beneath pressure embankments shall be carried out using embankment material for pressure embankments.

Soil replacement by displacement (compaction) is not permitted for the railway embankment.

Vertical drainage must not be carried out within designated groundwater bodies or in areas with soil and groundwater contamination.

The use of alternative binders for deep stabilisation requires special approval.

Technical solution / Soil reinforcement with mixed-in columns

In the following areas, a need for reinforcement measures has been identified during the system design phase. The technical solutions below are to be regarded as proposals. The contractor is encouraged to optimise and work towards cost-effective and efficient solutions.

Lime-cement columns are proposed to be installed within the following track sections:

km 63+340 – 63+780

km 66+240–63+780

Created by
[Created by]
Case number
[Case number]

Document date
[Document date]

Confidentiality level
[Confidentiality level]

km 70+200 – 70+270

km 71+140 – 71+220

km 71+440 – 71+690

km 75+420 – 75+380 (and under the pressure bench on the left-hand side)

km 75+420 – 75+480 (and under the pressure bench on the right-hand side)

km 76+620–77+000

km 78+540 – 78+690.

km 88+354 – 88+380 (northern embankment slope)

Technical solution / Ground reinforcement with embankment piling

In the following areas, a need for reinforcement measures has been identified during the system design phase. The technical solutions below are to be regarded as proposals. The contractor is encouraged to optimise and work towards cost-effective and efficient solutions.

Bank piling is proposed to be carried out in sections with loose soil conditions where the bank height exceeds 8 m and in connection with pile-supported bridges. Bank piling is dimensioned to geotechnical category GK3.

Bank piles 63+960–64+063

Concrete piles for bridge piers approx. km 64+063 – km 65+238

Embankment piles km 70+130 – 70+170

Bank piles km 70+300 – 70+340

Concrete piles for bridge abutments at km 70+247 and km

70+257 Embankment piles at km 71+850 – 71+891

Bank piles km 71+886 – 71+934

Concrete piles for bridge abutments at km 71+882 and km

71+889 Retaining piles km 72+580 – 72+620

Bank piles approx. km 72+730–km 72+745

Concrete piles for bridge abutment 2 between km 72+745 and km 72+755

Bank piles km 74+000–74+300

Bank piles km 75+700 – 75+740

Concrete piles, bridge abutments 77+259 and km 77+457 (bridge abutments 4 and 5)

Bank piles km 77+464 – 77+580

Bank piles km 79+880 – 79+941

Bank piles km 79+960 – 79+970. Concrete piles, bridge abutment km 79+960 Bank piles

km 80+380 – 80+500. Concrete piles, bridge

km 81+550 Bank piles km 81+625 – 81+635

Bank piles km 82+960 – 83+020

Created by
[Created by]
Case number
[Case number]

Document date
[Document date]

Confidentiality level
[Confidentiality level]

Bank piles km 85+500 – 85+760

Bank piles km 88+120 – 88+298

Bank piles km 88+354 – 88+380

Technical solution/Ground reinforcement with pile caps

In the following areas, a need for reinforcement measures has been identified during the system design phase. Pile cap at km 70+170 and km 70+300. To support the soil wedge outside the pile cap, lime-cement columns are installed in two rows where there is loose clay. In the section where there is peat beneath the soil wedge, the peat is reinforced using mass stabilisation or block stabilisation with cement

Pile decks shall be constructed in accordance with TRVINFRA-00226 “Bridges and bridge-like structures” and TRVINFRA-00227 “Bridges and bridge-like structures, Construction”.

Technical solution/Pre-loading with overload

In the following areas, a need for reinforcement measures has been identified during the system design phase. The technical solutions below are to be regarded as proposals. The contractor is encouraged to optimise and work towards cost-effective and efficient solutions.

Temporary geotechnical reinforcement measures in the form of preloading with overload within a number of sections to induce settlement beneath the railway embankment. Overload in the list below refers to the number of metres of standard-grade fill soil above the designed level for the track bed. In some cases, temporary pressure banks are also required to ensure stability with overload on the railway embankment during the construction phase.

km 63+300 – 63+340

km 73+140 – 73+180

km 87+900 – 88+060

Technical solution / Preloading without overload

In the following areas, a need for reinforcement measures has been identified during the system design phase. The technical solutions below are to be regarded as proposals. The contractor is encouraged to optimise and work towards cost-saving and efficient solutions.

Early construction of a railway embankment is also proposed in transition zones between soil reinforced with concrete piles and solid ground, between reinforcement with embankment piling and solid ground, and within the following sections:

Km 63+040 – 63+340

km 65+238 – 66+200

km 67+000 – 67+450

km 67+750–68+400

km 69+000–69+400

km 71+620 – 71+660

km 84+580 – 84+620

FB5. Additional equipment in bridge construction

Scope

Supplementary equipment in embankment construction shall be designed using detailed construction and structural documentation provided by the client’s external consultant in accordance with FB.5 and its sub-sections. It is the contractor’s responsibility to construct the works in accordance with the construction documents supplied by the external consultant.

Created by
[Created by]
Case number
[Case number]

Document date
[Document date]

Confidentiality level
[Confidentiality level]

FB6. Construction in the adjacent area

FB61 Physical barrier

The track's physical barrier consists of fencing, noise barriers and/or other measures for protection or design.

Physical barriers shall normally be positioned in accordance with the Standard Sections in Appendix X and in accordance with approved site plans.

Function

The design and construction of physical barriers, screens and fencing shall be carried out in accordance with the requirements set out in TRVINFR-00399 "Physical barriers for railways".

Technical solution

Standard section in accordance with Annex X

Technically approved materials (TGM) in the Swedish Transport Administration's materials catalogue shall be used for noise barriers and fencing and procured via Procurement and Logistics.

The entire line must have a physical barrier on both sides with an effective height of at least 2.5 m. The physical barrier must be positioned at least 3.5 m from the nearest track centre.

The requirement for a minimum effective height of 2.5 m for the physical barrier means that the height must be ensured through appropriate positioning. See: Figure (FB66). 38 below for appropriate positioning to maintain effective height.

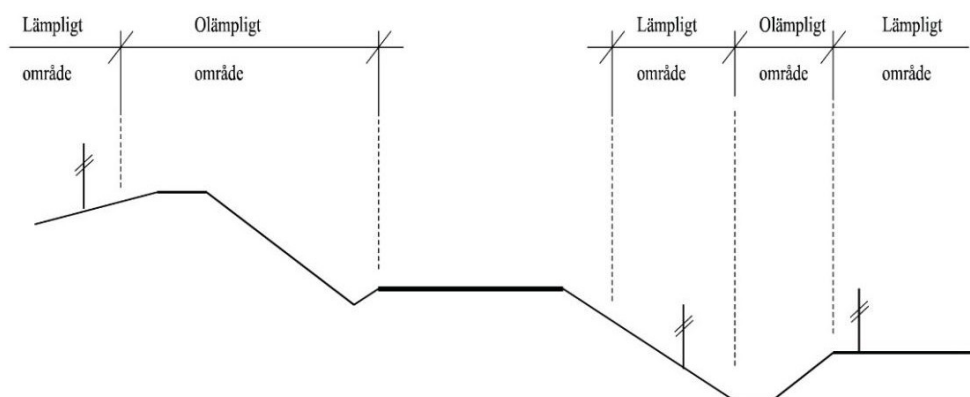

Figure (FB66). 38 Example of how a physical barrier (fence) can be positioned to maintain effective height.

Where the track is constructed as an elevated structure or on bridges over watercourses and roads, this is considered a solution that meets the requirement when the structural height is >2.5 m.

The physical barrier's anti-tunneling protection must extend at least 0.4 m below ground level. Anti-tunneling protection consisting of wildlife fencing must be buried 0.4 m deep, with the exception of rocky ground and boulder-strewn terrain where the fencing must be anchored to the rock.

Wildlife fencing shall have a maximum mesh size of 0.05 m.

Created by
[Created by]
Case number
[Case number]

Document date
[Document date]

Confidentiality level
[Confidentiality level]

FB62. Slope

Scope

The design requirements for slopes apply to all railway embankments, cuttings, pressure embankments and noise barriers along the route.

Function

Slopes shall be designed with the same vegetation type and soil as the surrounding area, so that the transition between the railway and the surrounding landscape blends in naturally without any visible joints.

No exposed surfaces with crushed material or blasted rock shall be present in the side area.

Technical solution

Facing of the inner slope at open ditches in cuttings and embankment slopes shall be carried out up to a level 1.5 m below the top of the embankment. In cuttings with drainage, no facing shall be carried out on the inner slope and up to a level of -0.7 m below the top of the embankment on the outer slope.

Slopes shall have gradients in accordance with standard cross-sections, with the exception of the deviations proposed in the section below. The slope crest and toe shall be rounded with radii between 5 and 10 metres.

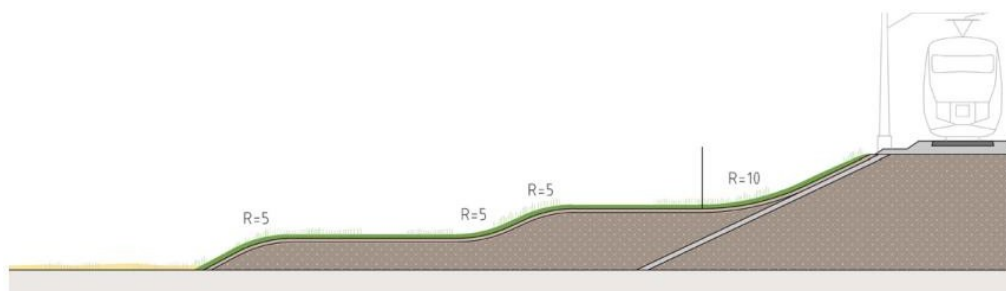

Figure (FB6).1. Principle for how the toe and crest of the slope should be rounded.

Slopes shall be covered with excavated material from areas with the same type of vegetation as the adjacent surroundings and designed with low ground-covering herbaceous/grass vegetation up to the level of the lower edge of the frost insulation layer. Covering shall be carried out with at least 0.1 m of excavated material to allow for natural re-establishment of vegetation.

Vegetation must be site-adapted, i.e. suited to the growing conditions at the respective location, such as access to light, water and nutrients.

If the seed bank in the excavated material is poor, the areas shall be seeded with a grass and meadow seed mixture to mimic the vegetation in the surrounding areas.

Meadows and grasslands should be mown in August/September. Mown plant material should be removed 1–2 weeks after mowing.

FB62b. Inner slope

Requirements for embankment slopes also apply here.

Specify requirements for slope gradient, surfacing and seeding unless these are covered by higher-level requirements.

Specify, for example, whether so-called raised arable land is to be created by raising the foot of the slope in accordance with the standard section or by setting requirements in the text. For example, down to a height of two metres measured from the profile plane, the slope must be constructed at

Created by
[Created by]
Case number
[Case number]

Document date
[Document date]

Confidentiality level
[Confidentiality level]

a gradient of 1:2; below this, the slope must be constructed at a gradient of 1:10 to create a usable surface that meets the adjacent arable land.

FB62c. Outer slope FB62c.

Outer slope/Soil Technical

solution

Cutting slopes shall not be designed steeper than 1:2 without support measures. In the case of erosion-prone soil, erosion protection shall be provided with thicknesses in accordance with TKgeo 13.

In fine-grained soils and/or frost-sensitive soils where there is a risk of erosion protection sliding down the slope, a gentler slope gradient should be considered. This applies in particular where the impact of surface water and groundwater on stability is significant.

FB62c. Outer slope/Rock

Scope

Planned rock cuts designed with a 3:1 gradient are shown below.

Below is a general summary of existing rock cuts that exceed RÖK:

- Total length of rock cuts deeper than 10 metres 2,500 metres
 - Of which on the left-hand side 1,300 metres
 - Of which on the right-hand side 1,200 metres
- Total length of rock cutting shallower than 10 metres 14,060 metres
 - Of which left side 6,815 metres
 - Of which right side 7,245 metres

In addition to this, rock excavation may also be carried out at, for example:

- A number of new and realigned roads
- In connection with utility yards
- For bridge supports/bridge foundations

Function

Rock faces must be surface-stable and structurally stable.

Surface stability refers to conditions along the surface of the rock cut – the presence of loose stones and boulders. Structural stability refers to conditions affecting the entire rock cut – risk of slippage/landslides.

No loose stones or boulders may be present on the remaining slope.

Rockfall debris must not encroach on the traffic area or pose a traffic safety risk.

In the case of deep rock cuttings, where the depth exceeds 10 metres, the rock cutting is widened by at least 4.7 metres away from the track, so that the distance from the centre line of the nearest track

Created by
[Created by]
Case number
[Case number]

Document date
[Document date]

Confidentiality level
[Confidentiality level]

centre line to the foot of the rock cutting is 10.6 metres. The area created by the widening shall serve as a catchment area for any falling rocks and small boulders. The widening shall also provide a working area for aerial work platforms and other machinery required for future maintenance of the cutting slope.

In cases where only short sections (<50 metres) with a depth of over 10 metres occur in otherwise shallower rock cuts, site-specific assessments must be carried out to determine whether widening should be carried out or can possibly be excluded.

In cases where only short sections (<50 metres) with a depth of less than 10 metres occur in rock cuts where the depth is otherwise over 10 metres, site-specific assessments must be carried out to determine whether widening should be carried out or can possibly be excluded.

Technical solution

During blasting, the blast areas must be covered with double weighting. When blasting within 50 metres of buildings, masts, overhead lines, infrastructure and other structures, the double weighting must be supplemented with splinter protection, geofilter class N5 or equivalent.

When blasting in the vicinity of a railway, TDOK 2015:0223 "Electrical safety regulations for work on or near railway-related high-voltage and train heating installations", Chapter 11.7, applies.

Electronic detonators must always be used provided that TDOK 2015:0223 "Electrical safety regulations for work on or near railway-related high-voltage and train heating installations" permits this, Chapter 11.7.

Where high-voltage power lines are located within 100 m of a planned rock excavation, a different type of detonator may need to be used in the vicinity of these installations. Consultation with the installation owner must take place before blasting work commences in the vicinity of these installations.

Factory-capsulated explosives or tubular charges shall be used.

All rock reinforcement must be designed for a technical service life of TLK 120. Clearing must be carried out so that the rock surface is completely free of soil and loose rocks.

Clearing behind the slope crest must be carried out to the rock surface and at least 1.5 m beyond the final slope crest. In the event of boulders protruding from the slope crest, the clearing must be adapted so that the area is cleared 1.5 m beyond the slope crest.

A description of the method and execution for all works shall be prepared. The intended execution, such as rock excavation and reinforcement, shall be reported. Existing rock engineering survey results shall be evaluated and supplemented where necessary.

Based on vibration measurement results, any corrective measures must be taken for each blast and recorded in the blasting log. In the event of exceedances, a deviation report must be drawn up. Blasting work and other vibration-generating work must be carried out in accordance with the restrictions set out in the "Risk Analysis of Vibration-Generating Activities during Construction" (provided after contract signing).

If there is a risk of water flowing out of a rock cut, or if water from above could lead to a risk of ice formation, water diversion or the installation of ice nets may be possible solutions.

After excavation, the position of the future slope crest shall be marked on the rock surface and an assessment of the need for any pre-reinforcement shall be carried out.

Rock excavation shall be carried out by drilling and blasting in accordance with AMA Anläggning code CBC.41 "Rock excavation for railways". Rock excavation for longitudinal cuts is normally carried out in rock excavation class 3. In areas with higher design requirements, or where rock stability is significant for other nearby structures, rock excavation class 1 or 2 shall be applied, as decided in consultation with the client.

Created by
[Created by]
Case number
[Case number]

Document date
[Document date]

Confidentiality level
[Confidentiality level]

Rock cuttings shall be designed in accordance with TDOK 2015:0198 “Standard sections for the railway” (BVS 1585.005), Chapter 6.5, as a basic requirement.

Technical solution/ Slopes steeper than 1:1

On rock outer slopes with a gradient steeper than 1:1, the blast damage zone in the remaining rock must not exceed 0.3 m. The deviation between the excavated and theoretical rock contours must not exceed 0.3 m on the slope face and 0.7 m at the slope toe.

Inspection

Following the uncovering of the rock surface, the client shall be given the opportunity to be present at the inspection to verify the design assumptions. The designed slope crest shall be marked out in the relevant inspection area.

Measurement results from vibration monitoring must be followed up and acted upon by carrying out the necessary measures to prevent damage to surrounding structures.

During the contract period, the contractor shall inspect slopes with regard to surface and overall stability, as well as potential future issues with landslides, and specify measures to meet the necessary requirements. The client shall be given the opportunity to participate in inspections. Inspections shall be carried out by means of reporting stability calculations, grouting logs, rock clearance logs, inspection reports, surveying, and mapping of completed slopes.

Ongoing rock clearance and rock inspection, in the form of visual inspections, shall be carried out to ensure stability. Rock clearance work shall be documented with photographic records and rock clearance logs.

Documentation shall be provided to the client on an ongoing basis.

Inspection of rock bolts shall be carried out in accordance with AMA Anläggning code CDC.14 “Rock anchoring with grouted bolts without pre-tensioning”.

Inspection of shotcrete shall be carried out in accordance with AMA Anläggning code EBF.31 Rock reinforcement with shotcrete.

Inspection of safety nets shall, where necessary, be carried out in accordance with AMA Construction Code CDC.1 “Rock anchoring with bolts, cables and nets”.

A preliminary investigation of the grouting material must be carried out to verify the properties of the grout. Where curtain grouting is to be carried out, a preliminary investigation must be conducted and a monitoring programme drawn up and approved by the client.

Once the rock slope has been excavated, the contour must be surveyed from the toe to the crest of the slope and photographed. Reinforcement measures carried out must be listed with unique numbers, together with their surveyed location and current data on type, extent, length and material, to be included in the final documentation.

All rock mapping must be carried out in accordance with TDOK 2023:0199 “Engineering Geological Mapping”. Results must be provided to the client no later than 24 hours after the mapping has been completed. Mapping must be carried out by a rock expert.

FB63. Retaining wall, screen/retaining wall

Function

Slopes along the railway embankment and pressure embankment shall be covered with poor topsoil/poor excavated material. Where necessary, the vegetation bed shall be sown with a mixture of grass and meadow seeds.

Pressure banks are present at the following locations: km

63+340 – km 63+755 Both sides

Created by
[Created by]
Case number
[Case number]

Document date
[Document date]

Confidentiality level
[Confidentiality level]

km 71+440 – km 71+600

km 71+600 – km 71+690 on the north side only

km 73+140 – km 73+180. Both permanent and temporary km 75+180 and

km 75+280 left-hand side

km 75+420 and km 75+480 right-hand side

km 76+050 – km 76+090 pressure banks on both sides km 76+620

and km 77+000 North side

km 76+620 and km 76+880, south side km

78+540 – km 78+690 North side km 78+600 – km

78+640 South side km 81+635 and km 81+700

South side km 82+100 – km 82+300 North side

km 82+180 – km 82+240 South side

km 84+580 – km 84+620 speed bumps on both sides

km 87+900 – km 88+060 speed bumps on both sides, both permanent and temporary

Function

The top surface of the embankments must slope away from the railway embankment to allow for drainage.

FB63. Embankment, screen/noise barrier

Function

Noise barriers shall be placed as close to the track as possible, and a ditch shall be constructed between the track and the barrier. The slope of a noise barrier shall have a gradient of 1:2 and a crest with a flat surface of two metres.

Noise barriers shall be constructed in accordance with Table (FB6).1 below.

Table (FB6).1. Noise barrier.

Location	Level (m) rel. RÖK	Distance (m) from nearest track centre	Other
Km 81+411– 81+476 North side	2	12 (14 m behind noise barrier)	Length 65 m
Km 81+622– 81+700 North side	2	12 (14 m behind noise barrier)	Length 78 m

Created by
[Created by]
Case number
[Case number]

Document date
[Document date]

Confidentiality level
[Confidentiality level]

Km 86+290– 86+390 North side	3	14	Length 100 m
km 89+475– 89+710 North side	3	14	Length 235 m

Technical solution

The external slope gradient of the noise barrier embankment shall be 1:2. The toe of the noise barrier embankments shall be rounded with a radius of approximately 5 metres. The crest shall have a flat surface of 2 metres.

Noise barriers shall be constructed from draining material with internal strength.

At the abutment of the landscape bridge over the Ålbergaån, km 81+554, the slope of the noise barrier must be designed with the same gradient as the slope of the abutment. The noise barrier must terminate at the adjacent noise barrier screen so that they overlap and the screen's termination is concealed. The fence shall be erected on the inside of the noise barrier to minimise visual impact on the surroundings.

FB63. Embankment, screen/Noise barrier

Scope

Refers to noise barriers as per Table (FB6).2.

Table (FB6).2. Noise barrier

Type	Position	Level (m) rel. RÖK	Distance (m) from nearest track centre	Insulation LRR (dB)	Absorption DL α (dB)	Other requirements
Cut m on bridge	Km 81+461– 81+637 North side	2	4.5	25	8	Absorbent towards the track side

Function

Noise barriers shall be designed and dimensioned in accordance with TRVINFRA-00226 “Bridges and bridge-like structures”, General requirements, and TRVINFRA-00227 “Bridges and bridge-like structures, Construction”.

The colour of noise barriers on bridges in design classes 1–2, as well as their post caps, posts, any doors and top plates, shall be concrete grey, RAL7037.

There must be sufficient clearance to allow passage between noise barriers and catenary poles to facilitate maintenance work on and around the pole.

The connection between the noise barriers and the ground, bridge and foundations must be watertight.

All noise barriers shall be sound-absorbing towards the track, except for the transparent sections.

There must be no gaps or cavities in the noise barrier that result in the specified acoustic requirements not being met due to sound leakage.

Created by
[Created by]
Case number
[Case number]

Document date
[Document date]

Confidentiality level
[Confidentiality level]

Noise barriers intended to act as a physical barrier must extend at least 0.4 m below ground level. The transition of the noise barriers to the surrounding ground must be adapted to the terrain.

The following acoustic requirements apply to noise barriers installed along high-speed rail lines on which trains travel at speeds of 250 km/h and above:

- The acoustic performance of noise barriers (sound absorption, sound insulation and diffraction) shall be specified in accordance with the SS-EN 1793 series of standards.
- Absorbent noise barriers shall achieve a sound absorption coefficient $DL\alpha$ of at least 8 dB in accordance with standard SS-EN 1793-1:2017.
- Noise barriers shall meet a sound insulation (DLR) of at least 25 dB in accordance with standard SS-EN 1793-2:2018 (diffuse sound field) or SS-EN 1793-6:2018 (direct sound field).
- If an assessment regarding the diffraction of noise barriers is required, for example for a component intended for installation on a noise barrier, the component must be declared for $DL\Delta DI$ under direct sound conditions in accordance with standard SS-EN 1793-4:2015.

Noise barriers shall be dimensioned for the conditions prevailing at the site, with particular consideration given to dead weight, wind load and snow load. For noise barriers, the snow load shall be selected in accordance with SS-EN 1794-1.

Technical solution

Cassettes for noise barriers are purchased via Procurement and Logistics as TGM materials.

Posts must be of H-section. Posts must be dimensioned for the prevailing conditions and for the aluminium noise barrier cassettes and the transparent sections purchased via Procurement and Logistics. The elements may be assumed to have dimensions of a maximum length of 5000 mm, a height of 500 mm and a width of 122 mm.

Transparent sections have a maximum length of 3000 mm.

Cassettes are not designed to withstand ground pressure; in such cases, they must be replaced with other materials. The difference between the standing surface and the top edge of the noise barrier must be at least 1.1 m at a right angle.

With regard to electrical safety, noise barriers adjacent to the track shall be constructed or adapted in accordance with TRVINFRA-00140 "General Application of the High-Voltage Regulations in the Design of the Swedish Transport Administration's Railway Facilities", K64368. Top elements for noise barriers are preferably constructed from non-conductive, UV-resistant material, as this does not require protective earthing or equipotential bonding.

Where noise barriers adjacent to the track are not constructed or adapted in accordance with the aforementioned requirements, the distances specified in SS-EN 50122-1:2022 ed. 3:2022 Figure 5 – A Public area apply.

There are two standard solutions for noise barriers: one for noise barriers on embankments and one for noise barriers on bridges.

A continuous noise barrier running across an embankment and a bridge, where the section on the embankment is less than 30 m, shall be designed as a noise barrier on a bridge. This applies to the entire noise barrier in Ålbergaån (bridge km 81+494 – 81+614). The lower part of the noise barrier on the embankment is adapted to the ground surface, see Figure (FB62). 32.

Created by
 [Created by]
 Case number
 [Case number]

Document date
 [Document date]

Confidentiality level
 [Confidentiality level]

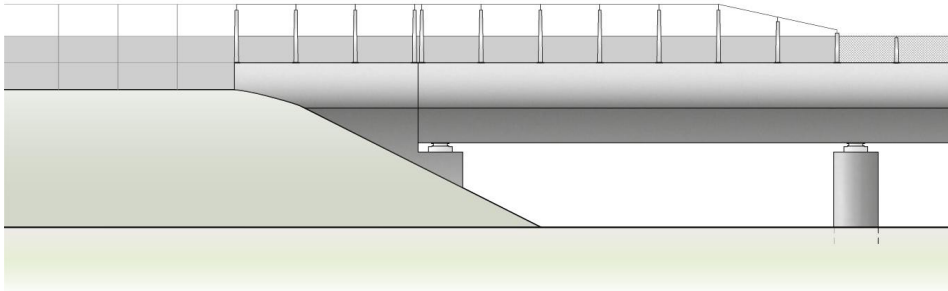

A continuous noise barrier running across the embankment and bridge, where the section on the embankment exceeds 30 m, shall be designed with a segment at right angles to the track at the transition between the noise barrier on the bridge and the noise barrier on the embankment, see Figure (FB63). 3 and 4.

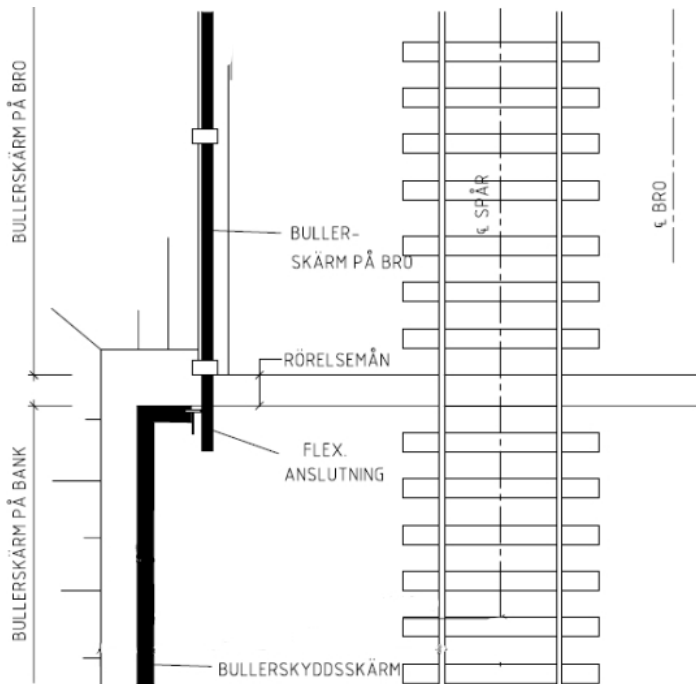

Figure (FB63). 3 Plan view of noise barrier on embankment, connection to bridge. Note: the figure shows a principle, not a technical solution.

Created by
 [Created by]
Case number
 [Case number]

Document date
 [Document date]

Confidentiality level
 [Confidentiality level]

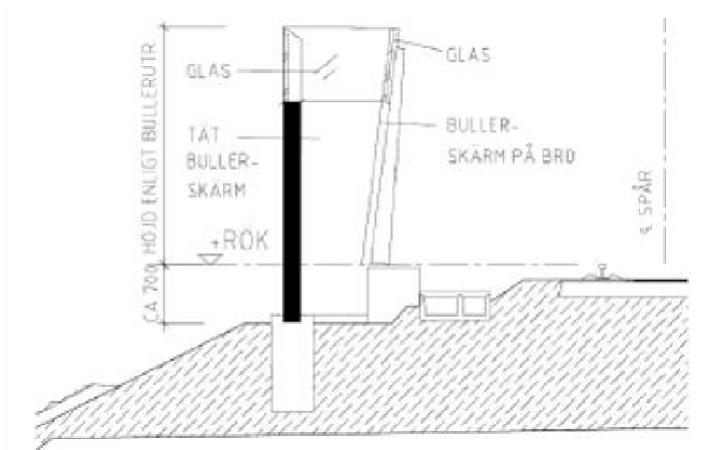

Figure (FB63). 4 Schematic section of noise barrier on embankment, connection to bridge. Note: the figure illustrates a principle, not a technical solution.

The transparent part of the noise barrier shall be fitted with a bird protection pattern, preferably a white dot or stripe pattern, across the entire surface of the barrier. The markings shall be UV-resistant and have the same warranty period as the transparent barrier as a whole.

Posts shall be installed at regular centre-to-centre distances. Posts shall be painted in a colour selected in consultation with the client.

Technical solution/ On ground

The lower edge of a noise barrier that does not connect to a structure must be sunk to the following depth below ground level:

- At least 0.2 m if the screen is anchored in the ground with a foundation.
- At least 0.1 m if the screen is anchored in the ground by its own weight without a foundation.

The extent of the transparent surface must not exceed what is necessary to meet the requirements for calculated noise reduction.

Technical solution/ On a bridge



Figur 169. Illustration. Landskapsbron med bullerskyddsskärm sett från dalgången från norr. Avslutet av bullerskyddsskärmarna döjs av bullerskyddsvallarna vilket bidrar till ett harmoniskt och bearbetat uttryck.

Figure (FB63). 5 Noise barrier on a bridge, with a large transparent surface area. Noise barriers shall be designed in accordance with the principle shown in Figure (FB63). 6

The screen on a bridge shall be constructed with a tight connection to the bridge girders.

Created by
 [Created by]
 Case number
 [Case number]

Document date
 [Document date]

Confidentiality level
 [Confidentiality level]

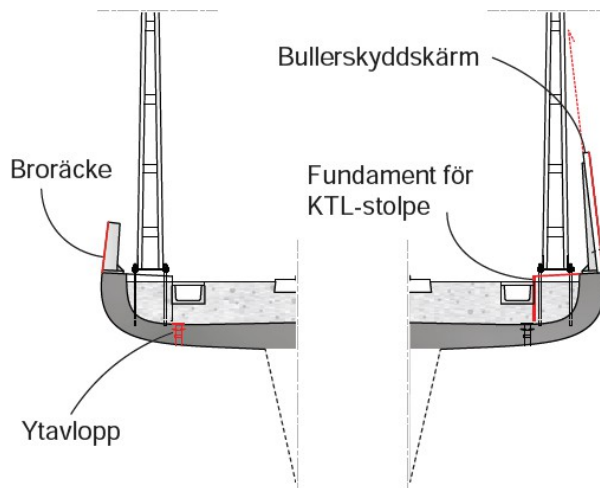

Figure (FB63). 6 Cross-section through a railway bridge and its components.

The bridge section, noise barrier and handrail are designed as a single unit, with the noise barrier sloping inwards towards the track at a ratio of 10:1 and abutting the outer edge beam, see Figure (FB63). 6.

The noise barrier is mounted against the inside of the uprights, see Figure (FB63). 6.

The sound-absorbing part of the noise barrier is made of metal with perforated sheet facing the track side and filled with sound-absorbing material.

The extent of the transparent surface must not exceed what is necessary to meet the requirements for calculated noise reduction. The noise barrier with an end section on the bridge has two segments from the end with a chamfer, see Figure (FB63). 4. The noise barrier on the abutment and wing wall is designed in the same way as the noise barrier on the bridge.

Verification

The acoustic performance of noise barriers (sound absorption, sound insulation and diffraction) shall be verified in accordance with the SS-EN 1793-1:2012 standard series.

Acoustic elements shall be declared in accordance with SS-EN 1793 with regard to sound absorption, sound insulation, load-bearing capacity, durability and, where applicable, with regard to falling parts. For screens made of glass, plastic or metal, light reflection shall also be declared in accordance with SS-EN 1793.

Verification shall be carried out by presenting certificates demonstrating that the noise barrier meets the requirements for technical service life and the loads that may be expected to occur. For acoustic elements, the manufacturer/supplier shall provide a declaration of performance, installation instructions and maintenance instructions.

The documentation in accordance with SS-EN 1793-1:2012 must be written in Swedish.

Acoustic elements shall, upon completion of installation, be physically marked with a CE mark containing at least information on the manufacturer, product name and declared characteristics. The CE mark shall be fully legible throughout the product's service life. The CE mark shall be placed at each end and in the event of a change in classification. The marking shall indicate the direction in which the information applies.

FB63. Embankment/sealed embankment

Technical solution

Sealing structures / embankments separating the facility from wetlands along the route shall be constructed from materials with a conductivity of 1×10^{-7} m/s or higher.

Created by
 [Created by]
Case number
 [Case number]

Document date
 [Document date]

Confidentiality level
 [Confidentiality level]

Sealing embankments shall be constructed at:

Km 73+520 – 73+620

Km 87+220 – 87+300

Km 87+350 – 87+450

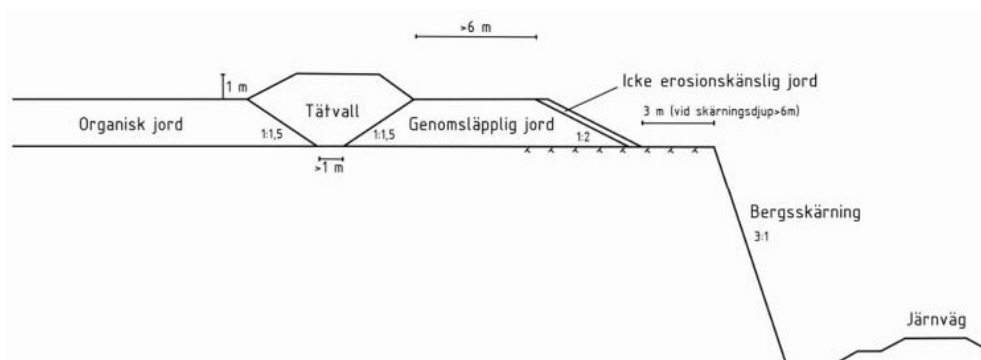

Figure FB62.1. Principle for the design of a sealing embankment

FB64. Vegetation with a plant bed

Scope

Requirements for vegetation and plant beds are set out in FB 6 Construction in side areas, FB62 Slopes and FB63 Embankments, screens

FB66. Fencing

Fencing for personal safety must meet the same functional requirements as wildlife fencing.

Fencing must be positioned so as not to create a disruptive impression in the environment.

The placement of the fence must minimise its visual and physical impact on the landscape.

Fencing must be installed, and where necessary fitted with gates, so that bridges are accessible for inspection and maintenance.

The fencing must be designed so that wildlife cannot be harmed.

Fencing must not be erected in such a way that it covers the openings of culverts. At junctions with culverts, fencing must be erected above and close to them.

The fence must not be designed with spikes on the top that risk injuring wildlife. This requirement does not apply within built-up areas, at bridges over tracks, maintenance yards and interchanges where the primary purpose of the fence is to prevent suicide and accidents involving people.

Where there are openings in the physical barrier, for example at junctions with existing unfenced railway lines, measures/adaptations based on local conditions must be implemented to prevent wildlife from being channelled onto the tracks. This can be achieved, for example, by directing animals away from the track via fencing and by adapting the design of the embankment and the surface of the ground.

Created by
[Created by]
Case number
[Case number]

Document date
[Document date]

Confidentiality level
[Confidentiality level]

When designing fencing, the need for and location of escape routes and evacuation options must be investigated.

On identified conflict sections, escape routes must be provided for animals that have accidentally ended up inside the physical barrier. This may apply where there is a risk of animals becoming trapped and forcing their way through the fencing, e.g. where fencing bottlenecks form where the railway crosses the E4, other roads and junctions, but the need for evacuation routes may also exist in other locations.

Additional fencing is to be installed at two locations, and the design is described in more detail in the following paragraphs. At one of the locations, the additional fencing is combined with wildlife crossings where there is a risk of wildlife becoming trapped in narrow obstacles or in situations posing a traffic hazard. For the other, the aim is to seal off small corridors and gaps between the railway and the E4.

Technical solution/Wildlife crossings

Wildlife crossings are planned for the following locations:

- Two wildlife crossings at Ålberga (km 80+790). The wildlife crossings are situated on the eastern and western sides of road 537 within the narrow strip of land between the railway line and the E4.

The wildlife crossings will be situated outside the permanent land acquisition area, but partly within the temporary one, and their installation requires agreement with the landowners.

FB66. Fencing/Wildlife fencing

Wildlife fencing shall be provided along the entire route in rural areas, outside built-up areas, unless other barriers are in place that fulfil the same function.

Function

Along the entire route, the lower section of the wildlife fence shall be constructed as a 1.0-metre-high wildlife fence combined with anti-burrowing protection.

FB66. Fencing/Gate

Scope

Pedestrian gates for access to the track via service roads shall be provided in the barrier and shall be situated at points, point diagonals, point crossings, rail lubrication units, converter stations, technical buildings, positioning equipment such as axle counters and equipment cabinets, and vehicle condition detectors.

Pedestrian gates for bridges at abutments on bridges shorter than 1000 m: one gate 50 m from one abutment; bridges longer than 1000 m: one gate 50 m from both abutments.

“Passages (gates, etc.) through the physical barrier that are used frequently shall be fitted with access control and detection systems based on local requirements. Advice: Detection may be achieved, for example, by means of a magnetic contact.”

Other vehicle and pedestrian gates are described under FB.66 Fencing/Gates/Technical Yards.

Function

The opening width of pedestrian gates shall be at least 1.2 m.

FB66. Fencing/Gates/Utility Yards Scope

Vehicle and pedestrian gates shall be designed in accordance with the technical yard drawings NS00-60-110-00000-0_0, sheets 0001–0019.

Created by
[Created by]
Case number
[Case number]

Document date
[Document date]

Confidentiality level
[Confidentiality level]

Technical solution

Utility yards shall be arranged in accordance with the Design Instructions for Safety Installations, Ostlänken: Section

5.5 Fencing for utility yards, with subheadings.

Section 5.6 Gates, with subheadings.

Section 5.7 Foundations and under-pouring with sub-headings.

For utility yards of types B, C, D, D1, D2 and E, 2 pedestrian gates and 1 vehicle gate shall be provided. A utility yard of type E may be connected to any of types B, C or D1, and therefore the same principle applies to pedestrian and vehicle gates as applies to these types.

For service yards of types A1 and A2, one pedestrian gate and one vehicle gate shall be provided, whilst for type A, only one vehicle gate shall be provided.

The opening width of vehicle gates must be at least 4.0 m for types A, A1 and A2, and for types B, C, D, D1 and E, gates facing the service road must be adapted to the type of vehicle and the turning area outside the service yard.

All pedestrian gates must have an opening width of at least 1.2 m.

FB7. Drainage systems, etc.

Scope

Drainage comprises the drainage of the embankment, the collection and diversion of surface water and drainage water from the embankment, maintenance yards, etc. within the track area, and the conveyance of flows through the embankment along the entire length of the new railway line.

Discharge points, with numbering and an approximate kilometre figure, are shown in Table FB7.1. The geographical location of the discharge points will be reported in full after the contract has been signed. *Table*

FB7.1

Outlet	Kilometre mark (approx.)
U32-46	63+650
U32-47	64+100
U32-48	67+350
U32-49	67+900
U32-50	68+300
U32-51 (U32-52)	69+350
U33-01	69+400
U33-02	69+950
U33-03	70+250
U33-04	70+400
U33-05	70+700
U33-06	71+850
U33-07	72+000
U33-08	72+300
U33-09	72+450
U33-10	72+750

Created by
[Created by]
Case number
[Case number]

Document date
[Document date]

Confidentiality level
[Confidentiality level]

U33-11	72+750
U33-12	73+100
U33-13	74+000
U33-14	74+600
U33-15	74+750
U33-16	75+650
U33-17	76+050
U33-18	76+100
U33-19	76+450
U33-20	76+500
U33-21	76+950
U33-22	77+300
U33-23	77+400
U33-24	77+800
U33-25	78+000
U33-26	78+450
U33-27	78+650
U33-28	78+900
U33-29	79+150
U33-30	79+450
U33-31	80+000
U33-32	80+450
U33-33	80+450
U33-34	81+450
U33-35	81+550
U33-36	82+250
U33-37	82+550
U33-38	82+650
U33-39	82+850
U33-40	82+950
U33-41	83+950
U33-42	84+800
U33-43	84+950
U33-44	85+650
U33-45	86+000
U33-46	86+350
U33-47	87+900
U33-48	88+300
U33-49	88+750
U33-50	88+900

Created by
[Created by]
Case number
[Case number]

Document date
[Document date]

Confidentiality level
[Confidentiality level]

U33-51	88+950
U33-52	89+300
U33-53	89+700
U33-54	89+750
U33-55	90+050
U33-56	90+200
U33-57	90+600
U33-58	90+800
U33-59	90+950
U33-60	91+050
U33-61	91+150
U33-62	91+300
U33-63	91+350
U33-64	91+400
U33-65	91+750

Function

Construction, design and dimensioning shall comply with TRVINFRA-00231 “Drainage, Dimensioning and Design”.

Execution shall comply with the requirements set out in the climate resilience document (see Chapter A. Common requirements/Requirements in the following regulations must be met):

The consequence class shall be determined in accordance with OLP0-08-025-4000-0_0-0021 (provided after contract signing).

Climate factor 1.38 shall be used for the operational phase.

The Swedish Transport Administration’s facility shall be protected against the consequences of torrential rain in accordance with OLP0-08-025-4000-0_0-0022, Chapters 3.3 and 4.5. A torrential rain analysis using 2D hydraulic modelling shall be carried out (in accordance with 08-025-4000-0_0-0022, Chapter 4.7) for those sections of the route that pass through areas with a high proportion of hard surfaces and locations that are difficult to assess. A torrential rain analysis using 2D hydraulic modelling shall also be carried out for the following features:

- Ponds
- Retention ditches

The stormwater system, which includes stormwater drains, pipes and retention systems, shall be located as close to the railway as possible and inside the fence where this is feasible.

The water level outside the track must not exceed 1.0 m below the underside of the rail in a 100-year event.

Pipes, culverts, drainage pipes and ditches shall be designed to ensure their functionality is maintained, taking into account the settlement—both total and differential—that occurs over the lifetime of the facility.

The railway facility’s drainage system shall be designed so that it does not affect the drainage or drainage depth of the respective land drainage company (in accordance with Chapter C1).

Utility yards shall be positioned at a height such that the utility yard’s service level is not exceeded at water levels with a return period of at least 50 years. The design return period is determined in accordance with the Ostlänken’s current

Created by
[Created by]
Case number
[Case number]

Document date
[Document date]

Confidentiality level
[Confidentiality level]

climate resilience document. The service level for technical yards is defined as the level 0.1 m below the ground surface on which the technical yard is situated. If the utility yard is situated lower than the level 0.9 m below RÖK, a flood analysis must be documented (requirement 680793). There must be a gradient of at least 1:10 away from the building.

Ditches around service yards must be located outside the respective service yard's fence.

Stormwater management shall primarily be by gravity flow (TRVINFRA-00231 "Drainage, Dimensioning and Design" K126640).

Pipes and culverts in settlement-prone ground must be provided with a reinforced pipe bed in accordance with AMA Anläggning 20 CEC.11.

Pipes and culverts at the transition between rock excavation and earth excavation shall be provided with backfill to taper the pipe in accordance with AMA Anläggning 20 CEC.12.

Pipes and culverts to be laid in frost-susceptible soil shall be installed in accordance with one of the following AMA Anläggning 20 codes:

- CEC.13 after excavation
- CEC.14 with a thick pipe bed
- CEC.15 with an insulated pipe bed

Land drainage contractors:

- The drainage function of the land drainage systems affected by the works must be maintained. Wet areas must not dry out and dry areas must not be flooded as a result of the new railway construction. Drainage from land drainage systems must, where necessary, be diverted past the new railway construction.
- The diversion of ditches must be carried out in such a way that their natural value is preserved and they continue to function as a corridor for wildlife. Open ditches must remain open.
- The railway facility's drainage system must be designed so that it does not affect the drainage or drainage depth of the respective land drainage companies.
- Discharges from the railway facility must not affect the drainage or drainage depth of the respective land drainage companies.
- Existing ditches, pipes, culverts and wells adversely affected by the works must be restored or replaced.

Technical solution

The bottom of the ditch and the drainage pipe must be laid at least 0.3 m below the terrace surface.

A culvert or pipe crossing a railway line must not be laid at a points or at an insulated joint.

Pipes and pipe fittings must be declared and quality-assured in accordance with the Construction Products Regulation (CPR).

At the outlet of the drainage system, a well with a sand trap must be installed.

Inspection

Filming via internal inspection using a colour TV camera with swivelling optics must be carried out and reported in accordance with "Svenskt Vatten P93".

Created by
[Created by]
Case number
[Case number]

Document date
[Document date]

Confidentiality level
[Confidentiality level]

The strength class of the pipe material must be specified. Videos and associated text documentation must be presented in software that allows linking between video, associated text and still images. Video must also be viewable in slow motion and at increased speed.

Software for viewing the material must be provided free of charge to the client.

FB71. Drainage systems

Scope

Drainage of the embankment body shall be provided along the entire length of the track.

Function

The drainage pipe system must be capable of being cleaned and flushed along its entire length.

Manholes and pipe outlets must be marked.

At outlets from the drainage system, a manhole with a sand trap shall be installed.

FB71b. Drainage pipe

Function

A drainage pipe must be designed so that the drained water is collected and carried away in an efficient and safe manner. There must be good hydraulic contact between the superstructure to be drained and the drainage pipe.

The pipe must meet the deformation requirements of tolerance class A, in accordance with Svenskt Vatten P91.

Technical solution

Ring stiffness must be at least in accordance with SN08.

Drainage pipes must have a maximum length of 400 m without an outlet.

The longitudinal gradient for drainage pipes designed to drain roads or railways must be at least 2.0‰. The longitudinal gradient should be at least 5.0‰ for roads and railways where this is possible with reasonable measures.

Where the longitudinal gradient is less than 5 ‰, the internal diameter shall be at least 200 mm.

Pipes for the drainage of railway superstructures shall have an internal diameter of at least 140 mm. Drainage pipes shall have a smooth interior and be manufactured in straight lengths.

Inspection

Inspection for deformation and deviation from alignment shall be carried out in accordance with Svenskt Vatten P91.

FB71c. Drainage well

Scope

Refers to drainage and/or cleaning wells in railway installations.

Created by
[Created by]
Case number
[Case number]

Document date
[Document date]

Confidentiality level
[Confidentiality level]

Function

A well on a drainage pipe shall be of the cleaning well type (minimum internal diameter 150 mm) or drainage well type (minimum internal diameter 400 mm). Drainage wells shall be fitted with a sand trap.

Cleaning wells shall be designed without a water trap.

Manholes shall be positioned so that operation and maintenance can be carried out with reasonable effort. From a maintenance perspective, the distance between manholes should be a maximum of 100 m.

Manholes may be constructed from either plastic or concrete. Plastic manholes must be quality-marked in accordance with Nordic Poly Mark.

Manholes, regardless of material, must withstand groundwater uplift. The design groundwater level for uplift shall be the groundwater surface at ground level in the area where the respective manhole is located.

Wells must meet the requirements for well level in tolerance class A, in accordance with Svenskt Vatten P91. The wells must be cleanable and flushable.

Inspection

Inspection of the well level shall be carried out in accordance with Svenskt Vatten P91.

FB72. Stormwater system

Scope

In accordance with FB7.

FB72b. Piping

Function

Stormwater pipes shall be designed so that drainage water is discharged efficiently and safely. Stormwater pipes within or adjacent to railway lines shall comply with the requirements of TDOK 2014:0945 "Laying of pipes and pipe crossings within or adjacent to railway lines".

Pipes and culverts beneath railway tracks shall be dimensioned so that their function can be maintained for at least 80 years with normal maintenance.

Pipes and culverts in close proximity to railway tracks must be dimensioned so that their function is maintained for at least 80 years with normal maintenance if railway traffic is affected during maintenance of culverts and pipes.

Technical solution

Gravity drains shall have a minimum longitudinal gradient in accordance with (TRVINFRA-00231 "Drainage, Dimensioning and Design" *Table 12-1*, taking into account self-cleaning.

Gravity pipes that only discharge drainage water, not surface water, are exempt from the minimum gradient requirement in accordance with *Table 12-1*.

Gravity pipes that only discharge drainage water have the same longitudinal gradient requirements as drainage pipes.

The pipe bed shall be constructed in accordance with AMA Anläggning code CEC.2114, Pipe bed for pipes in roads, flat areas, etc., category A, and railways.

Created by
[Created by]
Case number
[Case number]

Document date
[Document date]

Confidentiality level
[Confidentiality level]

Backfilling shall be carried out in accordance with AMA Anläggning code CEC.3114, Backfilling for pipes in roads, flat areas, etc. category A and railways.

The remaining backfill shall be carried out in accordance with AMA Anläggning code CEC.4114, Remaining backfill for cables in roads, flat areas, etc. category A and railways.

FB72b. Pipes/Gravity pipes

Pipes shall be designed to allow for inspection and flushing. Stormwater pipes must not have a drainage function

Pipes shall meet the requirements for tightness, deformation and alignment deviation in tolerance class A, in accordance with Svenskt Vatten P91.

Erosion protection shall be provided at outlets to watercourses in accordance with TRVINFRA-00230 "Requirements for Geotechnical Engineering, Dimensioning and Design", Chapter 6.1.3.

Technical solution

Ring stiffness must be at least in accordance with SN08. Pipe fittings must be of the same stiffness class as the pipes.

Inspection

Checks for tightness, deformation and alignment deviation shall be carried out in accordance with Svenskt Vatten P91.

FB72c. Manhole

Function

Manholes on stormwater pipes shall be designed to allow for inspection and flushing of the manholes and pipes.

Manholes must meet the requirements for watertightness and manhole level in tolerance class A, in accordance with Svenskt Vatten P91. Manholes must be marked with unique ID numbers.

Technical solution

The maximum distance between two manholes on a pipe must not exceed 100 m.

Inspection

Checks on watertightness and manhole level must be carried out in accordance with Svenskt Vatten P91.

FB72c. Manhole/Stormwater manhole

Scope

Applies to all stormwater drains with the exception of drains within building structures.

Function

A stormwater drain must handle surface water from the area it is intended to serve.

Created by
[Created by]
Case number
[Case number]

Document date
[Document date]

Confidentiality level
[Confidentiality level]

The drain must be watertight but open to flow from connecting pipes. The drain must be adapted to the specific function and type of pipework.

Stormwater drains must trap sand and other objects carried by stormwater. Pools of surface water must not form adjacent to the drain cover.

Stormwater drains must have a diameter of at least 400 mm and be fitted with a sand trap of at least 70 litres. Covers must meet the requirements of SS-EN 124, including all sub-standards in accordance with the latest version. Prefabricated plastic components for drains must meet the requirements for Nordic Poly Mark quality certification.

Prefabricated components for concrete manholes must meet the technical specifications stated by the manufacturer and be of a type that complies with the requirements of SS-EN 1917 and supplementary Swedish requirements in SS 227001:2005.

FB72c. Manhole/Access shaft

Manhole chambers shall be reinforced.

Access chambers shall be located at the break points in the pipeline.

Manhole chambers with a depth greater than 6 m shall be fitted with fall protection or a landing platform.

FB72d. Equalising facility/Reservoir

Scope

Surface water from the railway should primarily be managed within the railway area and preferably in ditches. If required for discharge to the receiving water body, a management facility must be constructed. The scope is to be investigated and coordinated with the client. Previous studies have identified a need for four ponds, and these are detailed in (OLP3-51-025-33-0_0-0210 and OLP3-51-025-32-0_0-0210 Design Memorandum on drainage, to be provided after the contract is signed).

Function

Function and design are determined in consultation with the client.

Technical Solution

Ponds should have an organic shape so that they appear as a natural feature within the landscape.

FB73. Ditch

Scope

A ditch is constructed to prevent harmful water accumulation and to stop water from a railway track from flowing onto adjacent land. A ditch also serves to divert surface water from adjacent land so that it does not pool against the railway track and to prevent erosion at the foot of the railway embankment.

Function

Ditches shall be designed in accordance with the standard

section in [Appendix X](#). The ditch depth shall be at least 0.4

m.

Created by
[Created by]
Case number
[Case number]

Document date
[Document date]

Confidentiality level
[Confidentiality level]

Open ditches shall be constructed where stability permits.

The minimum longitudinal gradient shall be 5.0 ‰ where this is possible with reasonable measures.

Ditches constructed for the purpose of draining the superstructure shall be designed so that the bottom of the ditch lies at least 0.30 m below the terrace surface.

Ditches shall be protected against erosion.

The discharge of ditches into natural watercourses must not cause turbidity.

Where there is a risk of erosion, the bottom and slopes of the ditch shall be fitted with erosion protection. The erosion protection shall be dimensioned in accordance with Geokonstruktion, Dimensioning and Design.

FB73. Ditch/retention ditch

Scope

As a general rule, retention ditches are only located immediately after long cuttings where water accumulates and may reach such high flows that it is necessary to delay it before it can be discharged to a receiving water body. At the same time, the aim is to achieve an acceptable discharge flow prior to diversion from the track's stormwater system to an external receiving water body and its current flow capacity.

Initially, a solution is being designed where retention takes place in a longitudinal ditch.

The scope is being investigated and coordinated with the client. Previous studies indicate a proposed scope for the ditches, and these are set out in documents provided after the contract is signed (OLP3-51-025-33-0_0-0210 and OLP3-51-025-32-0_0-0210; Design Memorandum on drainage).

Function

Retention ditches shall be constructed in such a way as to ensure the function of retaining the intended volume of stormwater. An outlet well with an overflow function shall be constructed at the retention ditch.

Retention ponds and retention ditches shall be designed with an overflow function to accommodate a 100-year flood with a climate factor of 1.38.

FB73. Ditch/Cross-ditch

Scope

Cutting ditches shall be constructed at all points along the route where the railway runs through a cutting.

Function

Cutting ditches drain, collect and divert surface and drainage water from the track and surrounding terrain.

FB73. Ditch/ Embankment ditch

Scope

Embankment ditches are provided to prevent harmful water accumulation at the embankment and to prevent water from a railway/road from flowing onto adjacent land. The embankment ditch also serves to divert surface water from adjacent land so that it does not pool against the embankment body and to prevent erosion at the foot of the embankment slope.

Function

Created by
 [Created by]
Case number
 [Case number]

Document date
 [Document date]

Confidentiality level
 [Confidentiality level]

The embankment ditch is positioned 2 m from the foot of the embankment, as this allows a wildlife fence to be placed between the embankment and the edge of the ditch. For a low rock embankment, the distance can be set at 2 m from the point where the 1:1.5 gradient of the rock fill meets the subgrade. For a high rock embankment, a distance of at least 1.0 m from the foot of the embankment slope is sufficient, as the distance is then greater than 2 m inwards to the foot of the rock fill (see example figure below).

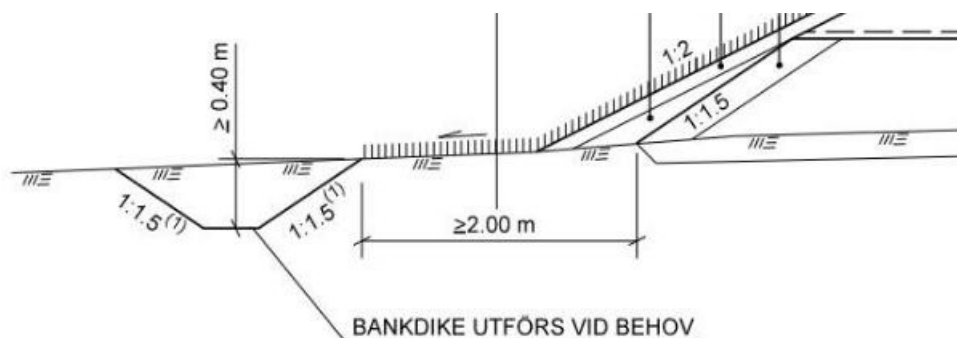

Figure (FB73).1. Schematic diagram showing how a bank ditch can be positioned for a low embankment

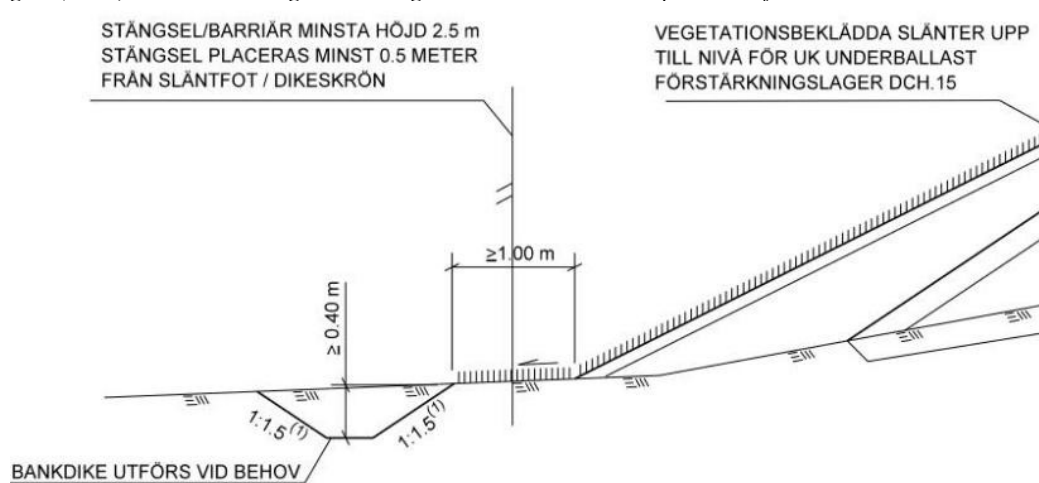

Figure (FB73).2. Schematic diagram showing how a bank ditch can be positioned for a high bank

Ditch/Overditch

Function

An overflow ditch must be provided if there is a risk that water from higher ground will run down the cut slopes and cause damage.

Technical solution

The over-ditch is constructed above cuttings where necessary.

The over-ditch is constructed by excavating soil. Where rock is present at the surface, alternative solutions to the over-ditch must be developed.

Created by
 [Created by]
Case number
 [Case number]

Document date
 [Document date]

Confidentiality level
 [Confidentiality level]

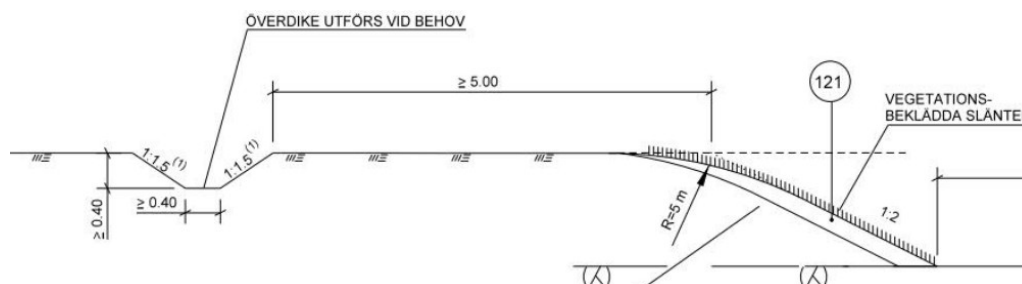

Figure (FB73).3. Schematic diagram showing how a top drain can be positioned

FB73. Ditch/Verge ditch

Function

Verges shall be positioned so that their function is ensured, particularly in marshland and boggy areas.

Technical solution

The verge ditch is laid 3–5 m from the foot of the embankment. The depth of the ditch is limited so that water is allowed to flow through it. The width of the ditch bottom should be approx. 0.4 m.

FB74. Culvert

Scope

The scope is investigated and coordinated with the client. Previous investigations indicate a need for culverts, and these are detailed in OLP3-51-025-33-0_0-0210 and OLP3-51-025-32-0_0-0210 (Design Memorandum on drainage).

Function

Culverts in watercourses must be positioned and designed in accordance with requirements regarding aquatic fauna passage, so that benthic organisms, fish and other animals can migrate unimpeded both upstream and downstream.

An impact assessment must be carried out to assess the consequences of a culvert becoming blocked.

Culverts with a circular cross-section shall be designed and positioned so that the water level in the culvert is a maximum of 85 % of the culvert's capacity during a 100-year event.

Culverts shall primarily be dimensioned and designed so that screens are not required at the upstream or downstream ends.

Culverts functioning as aquatic fauna passages shall be designed so that no backwater occurs at the culvert's inlet, outlet or anywhere inside the culvert across the entire flow range up to MHQ.

Culverts used for water conveyance shall be laid at a greater depth than the bottom of the adjacent ditch or connecting watercourse, with a minimum over-depth in accordance with TRVINFRA-00231 "Drainage, Dimensioning and Design", Table 12-4.

The water depth in a fauna passage for aquatic animals shall mimic the natural depth of the watercourse, and the watercourse's normal flow velocity shall remain unchanged through the water-carrying culvert.

A culvert intended to function as a water fauna passage must have a diameter sufficient to fulfil that function.

Created by
[Created by]
Case number
[Case number]

Document date
[Document date]

Confidentiality level
[Confidentiality level]

Culverts intended to serve as passages for aquatic fauna must have a gradient that ensures this function is fulfilled.

Culverts must be protected against erosion in accordance with TRVINFRA-00231, “Drainage, Dimensioning and Design” K112049. Please also note the requirements regarding erosion protection for culverts serving as aquatic fauna passages. Erosion protection in fauna passages for aquatic animals in watercourses below the highest high-water level must be covered with non-sharp-edged stone material (e.g. moraine) dimensioned so that it is not washed away.

Above the highest high-water level, erosion protection in fauna passages for aquatic animals must be covered with excavated material or other soil material that provides good conditions for the re-establishment of vegetation.

The bottoms and bottom substrate of culverts functioning as aquatic fauna passages shall be designed to resemble the watercourses’ original bottoms.

Parallel culverts should be avoided where possible.

Culverts must meet the requirements for deformation and directional deviation in tolerance class A, in accordance with Svenskt Vatten P91.

Technical solution

The angle of intersection between the culvert and the road or railway must be as straight as possible. The angle of intersection between the culvert and the railway must not be less than 80 degrees. A culvert crossing a bank structure:

- must be laid at least 5 m from the nearest catenary pole
- must be laid beneath longitudinal cables
- must not be laid in the cable-free zone and must always be laid below the cable-free depth (1.5 m below RUK).

A culvert intended to function as a water fauna passage must be laid with a gradient of between 0 and 5 ‰. A culvert may be laid with a steeper gradient if the structure is designed to withstand a steep gradient whilst maintaining its function as a water fauna passage.

Culverts beneath railway tracks must have an internal diameter of at least 800 mm.

Culvert ends must be cut in line with the embankment.

Inspection

Inspection for deformation and alignment deviation shall be carried out in accordance with Svenskt Vatten P91.

Culverts must be inspected by CCTV in accordance with Svenskt Vatten P93. Fault codes and classifications must comply with Svenskt Vatten P93.

Unique component IDs must be used.

Checks to ensure that aquatic fauna passages meet the specified requirements must be carried out. Verification must be carried out in accordance with TMALL 0990 and reported to the client immediately upon completion of the work.

FC. Signalling system

Scope

It is part of the TLS contractor’s undertaking to design and construct the signalling system in accordance with the construction specifications and the technical solution comprising a set of construction drawings supplied by the client’s consultant.

Created by
[Created by]
Case number
[Case number]

Document date
[Document date]

Confidentiality level
[Confidentiality level]

Signalling equipment included under Chapter FC Signalling System shall be supplied by the client upon call-off.

FD. Railway Power Supply

Scope

See constituent parts and interfaces under FE

FE. Electrical System

Scope

It is part of the TLS contractor's undertaking to design and construct the electrical system in accordance with the construction specifications and the technical solution comprising a set of construction drawings supplied by the client's consultant.

Inspection/Electrical safety

The client must be given the opportunity to be present when power is applied to plant components. Power must not be applied without consultation with the client.

FF. Telecommunications systems

Scope

It is part of the contractor's undertaking to carry out and construct the telecommunications systems in accordance with the construction specifications and the technical solution comprising a set of construction drawings supplied by the client.

The contract covers the supply and installation of equipment unless otherwise specified.

The contractor is responsible for installation of everything except active transmission equipment; this includes, for example, technical buildings with cable ladders, racks and basic fittings so that the client, together with a subcontractor, can install, test and commission the active equipment.

Final construction drawing designs are supplied by the client to the contractor for the manufacture and installation of passive equipment. The contractor carries out all work relating to passive equipment.

The client is responsible for the active equipment, including the installation, testing and commissioning of, for example, switches, wavelength systems and antenna systems.

Groundworks and foundations for technical buildings are carried out by the TLS contractor.

Groundworks and foundations for radio towers are carried out by the TLS contractor in accordance with the tower manufacturer's standard drawings.

FG. Construction supervision system

Scope

It is part of the contractor's undertaking to design and construct a site monitoring system in accordance with the construction specifications and technical solution comprising a set of construction drawings supplied by the client.

FJ. Cable ducting system

Scope

Created by
[Created by]
Case number
[Case number]

Document date
[Document date]

Confidentiality level
[Confidentiality level]

It is part of the contractor's undertaking to design and construct the cable ducting system in accordance with the construction specifications and technical solution comprising a set of construction drawings supplied by the client.

FK. Technical building, ducts, cabinets, etc.

Scope

It is part of the contractor's undertaking to carry out and construct the technical building, ductwork, cabinets, etc. in accordance with the construction specifications and technical solution comprising a set of construction drawings supplied by the client.

Created by
[Created by]
Case number
[Case number]

Document date
[Document date]

Confidentiality level
[Confidentiality level]

G. BRIDGE STRUCTURE

The bridges shall be designed with the aim of ensuring they are constructed cost-effectively and safely. Despite specified design requirements, the Contractor shall actively work to find cost-saving and efficient solutions for the construction. The Client will be involved in the work and, together with the Contractor, resolve any challenges that arise.

The technical service life of bridges shall be 120 years.

G. Bridge design / Road bridge

Scope

Table (G).1. Scope Road bridge

City centre bridge at km (1)	Designation	Proposal sketch/model (2)	Design class
69+012	New road bridge over railway (Road 608)	OLP3-21-W0-32-0_0-8630.dwg	2
80+788	New road bridge over the railway (Road 531)	OLP3-21-P0-33-0_0-8822.dwg	2
84+212	New road bridge over railway (Eriksgatan)	OLP3-21-W0-33-0_0-8830.dwg	2
87+794	New road bridge over railway	OLP3-21-W0-33-0_0-8914.dwg	2
<p>(1) Distance measurement on the new main line (OLP3 distance measurement). (2) Proposal sketches and models are for illustrative purposes only and should not be regarded as a complete technical solution.</p>			

Function

Aspedal at road bridge KM 69+012: The road embankment connecting to the bridge should be perceived as a natural, low, elongated ridge in the landscape that gradually merges into the flat landscape.

Eriksgatan at road bridge KM 84+212: The road bridge should be well integrated into the landscape and not be perceived as a separate, constructed feature. Slopes should be designed so that travellers along the road can see the landscape with an unbroken horizon.

Technical solution

Road bridges and associated support structures shall be dimensioned for traffic in accordance with Tables (D).12 and (D).14.

Those parts of bridges over railways that affect railway traffic during maintenance shall be constructed of concrete.

For road bridges over railways, a combined vehicle restraint system and suicide prevention barrier in accordance with point two of K135258 in TRVINFRA-00227 "Bridges and bridge-like structures, Construction" shall be used.

Handrails on bridges and/or retaining walls shall be fixed to the top of the edge beam. Base plates must not be cast in place. Where noise barriers are installed, the base plate shall, as far as possible, be constructed without being cast in place. Other provisions regarding handrails are set out in Chapter DC1. Handrails / Bridge Handrails.

Protective impregnation shall be applied to all surfaces in the road environment, as well as visible surfaces on the front wall, bearing pad and associated edge strips.

Created by
[Created by]
Case number
[Case number]

Document date
[Document date]

Confidentiality level
[Confidentiality level]

Anti-graffiti protection shall be applied to all visible surfaces of the substructure. Intermediate supports shall be protected against graffiti up to 5.0 m from the finished ground level.

Bridges shall be constructed with raised edge beams.

Concrete casting shall be carried out in dry conditions.

In the case of an exposed road bridge, particularly in a landscape-sensitive area, efforts should be made to reduce the height of suicide protection as far as possible by eliminating/lowering points where one can place a foot.

G. Bridge construction / Railway bridge

Scope

Table (G).2: Scope – Railway bridge

Bridge at km (1)		Designation	Proposed sketch/model (2)	Design class
Start	End			
64+063	65+238	New landscape bridge over Road 52, TGOJ and private road	OLP3-21-460-32-64_65-0001 to -0006.pdf	3
65+507		New railway bridge over wildlife crossing	OLP3-21-W0-32-0_0-8622.dwg	1
70+251		New railway bridge over wildlife crossing and watercourse	OLP3-21-W0-33-0_0-8710.dwg	1
71+885		New railway bridge over Road 610	OLP3-21-W0-33-0_0-8712.dwg	1
72+239	72+573	New landscape bridge over Björnbäcken	OLP3-21-W0-33-0_0-8713.dwg	3
72+749		New railway bridge over minor road	OLP3-21-W0-33-0_0-8714.dwg	1
74+002		New railway bridge over wildlife crossing and minor road	OLP3-21-W0-33-0_0-8716.dwg	1
75+681		New railway bridge over wildlife crossing and minor road	OLP3-21-W0-33-0_0-8719.dwg	1
77+259	77+457	New railway bridge over Gammelstadsbäcken	OLP3-21-460-33-77_77-0001.pdf	2
79+950		New railway bridge over wildlife crossing and watercourse	OLP3-21-W0-33-0_0-8820.dwg	1
81+494	81+614	New landscape bridge over the Ålbergaån	OLP3-21-460-33-81_81-0001.pdf	3

Created by
[Created by]
Case number
[Case number]

Document date
[Document date]

Confidentiality level
[Confidentiality level]

Table (G).2: Scope of railway bridge

Bridge at km (1)		Title	Proposal sketch/model (2)	Design class
Start	End			
82+887		New railway bridge over minor road	OLP3-21-W0-33-0_0-8828.dwg	2
85+951	86+079	New landscape bridge over the Vretaån	OLP3-21-460-33-85_86-0001.pdf	3
88+326		New railway bridge over the outlet of Sägkärret	OLP3-21-W0-33-0_0-8917.dwg	2
89+745		New railway bridge over minor road	OLP3-21-W0-33-0_0-8923.dwg	2
90+300		New railway bridge over wildlife crossing	OLP3-21-W0-33-0_0-8926.dwg	1

Function

Box girder bridges:

These belong to the longitudinal design family, which within the East Link has a rounded design language. This design language gives the East Link a uniform appearance. The rounded form is an identity-defining and fundamental architectural quality that must not be deprioritised or adapted to the site.

Technical solution

Bridges shall be designed for load model LM 71 (and SW/0 where required) with $\alpha=1.33$.

The permitted speed for load model HSLM is set at 250 km/h. The bridges must be designed with ballasted track.

Railway bridges with two tracks, longer than 1000 m, shall have two paved walkways with a width of 0.90 m. Single-track bridges longer than 1000 m shall have one paved walkway.

On bridges, the surface alongside the track, including walkways, shall be constructed to at least the height of the nearest rail (RUK) to the greatest extent possible, taking into account any rail elevation.

Those parts of railway bridges that affect railway traffic during maintenance shall be constructed of concrete.

Those parts of bridges over railways that affect rail traffic during maintenance shall be constructed of concrete.

Railings on bridges, retaining walls and troughs shall be bolted to the top of the edge beam or wall, and the base plate shall not be cast in concrete. Where noise barriers are installed on bridges, retaining walls and troughs, the base plate shall be cast in concrete.

The outer side of the posts/noise barriers/railing shall continue in a continuous line/angle from the outer edge of the edge beam.

Graffiti protection shall be provided on all visible surfaces of the substructure. Intermediate supports shall be protected against graffiti up to 5.0 m from the finished ground level.

Bridges shall be constructed with a raised edge beam.

Concrete casting shall be carried out in dry conditions.

The technical solution for noise barriers on the bridge is set out in FB63

Technical solution/Bridge over Road 52 and TGOJ

Space beneath the landscape bridge for Road 52 must allow for a future expansion of Road 52 to 1+1 lanes, as well as a footpath and cycle path along one or both sides of the road.

Created by
 [Created by]
Case number
 [Case number]

Document date
 [Document date]

Confidentiality level
 [Confidentiality level]

GJ. Crossing structure

Technical solution

At the transition to railway bridges, a transition structure in the track substructure shall be constructed behind the bridge abutments, see Figure (G).1, Figure (G).2 and Figure (G).3.

The transition structure shall be constructed to the full height H as shown in Figure (G).3

Lightweight fill shall not be used within the transition structure towards the bridge.

The transition structure shall be constructed using materials in accordance with AMA Anläggning DCH.15. The layer thickness after compaction shall be no more than 300 mm within the transition structure.

Compaction within the transition structure shall be carried out in accordance with AMA Anläggning Table CE/5 with double the number of passes. Compaction closer than 1 m from the base slab or vertical structure shall be carried out using a vibratory plate with a maximum weight of 700 kg.

Cable and pipe penetrations in the transition structure are not permitted.

PLAN ÖVER ÖVERGÅNGSKONSTRUKTION

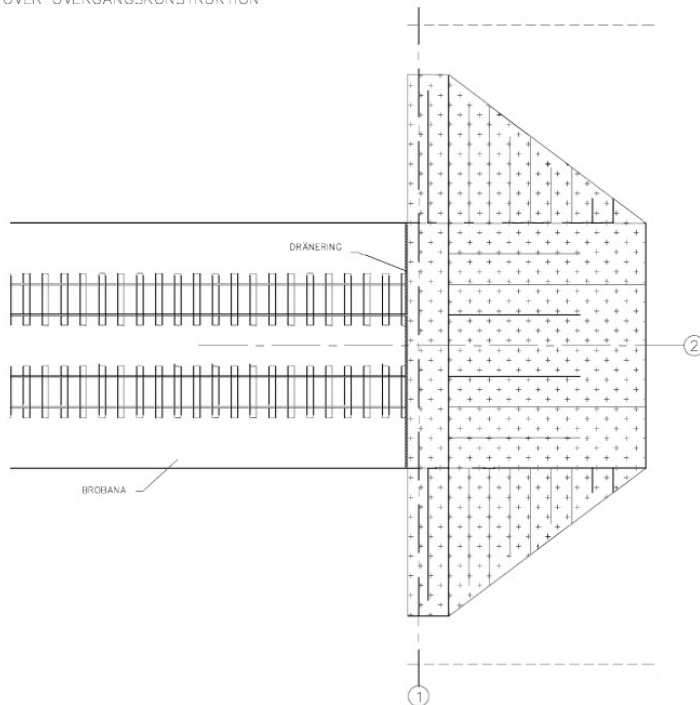

Figure (G).1 Transition structure for ballasted track system, plan
SEKTION 1

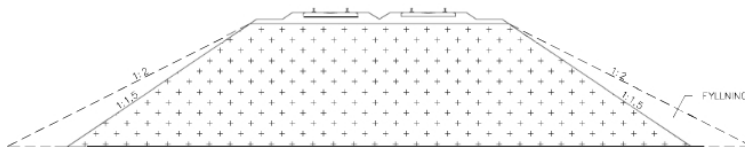

Figure (G).2 Transition structure for ballasted track system, section 1

Created by
 [Created by]
Case number
 [Case number]

Document date
 [Document date]

Confidentiality level
 [Confidentiality level]

SEKTION 2

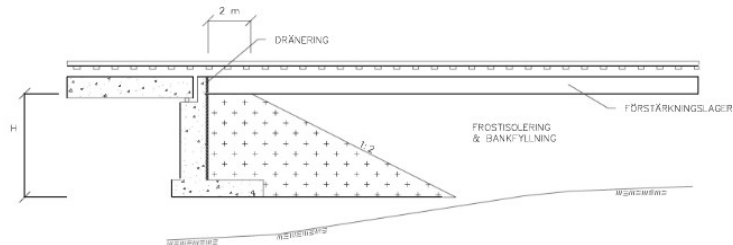

Figure (G).3 Transition structure for ballasted track system, section 2

GK. Drainage system

Technical solution

Foundation drains shall be made of stainless steel.

Drainage channels adjacent to the edge beam must not contain any epoxy. No surface water must be discharged directly into watercourses.

Water flowing from downpipes mounted on bridge piers must be directed to a draining surface.

Created by
[Created by]
Case number
[Case number]

Document date
[Document date]

Confidentiality level
[Confidentiality level]

V. EXTERNAL STRUCTURE

V. External construction/Existing cables and equipment

Scope

Where conflicts with cables and installations arise, measures shall be agreed with the client and the respective cable owners.

X. DOCUMENTATION

The contractor shall prepare documentation of such scope and content that it can be demonstrated/verified that the specified requirements are met.

Documentation shall cover design, execution and final documentation.

Delivered documents shall be accompanied by a quality certificate that clearly verifies the status of the documents

Quality assurance in the form of self-inspection, independent review, etc. shall be substantiated and indicated by marking on the relevant document and/or by a quality certificate. Quality assurance shall be documented and presented to the client upon request.

The purpose of these requirements is to focus on content; the contractor must have the resources to carry out the work appropriately and in accordance with the scope, in consultation with the client.

NOTE:

X. Documentation/Digital project management

For digital project management in this contract, the Digital Project Management Plan, Ostlänken version 2.0 and its appendices apply. The Digital Project Management Plan sets out requirements for all deliverables, such as construction documents, relationship documents and management data, and refers to the applicable regulations for these.

Appendices to the Digital Project Management Plan, Ostlänken:

- Requirements list for digital project management, Ostlänken version 3.0.
- TDOK 2023:0080 Instructions for sharing and delivery of product documents, Ostlänken
- TDOK 2023:0106 Instructions on naming conventions and metadata, Ostlänken version 2.0
- TDOK 2023:0107 Instructions for the Project Portal, Ostlänken version 2.0
- TDOK 2023:0167 Instructions for object-oriented information model, Ostlänken version 1.0
- GIS guidance version 2.0 (advisory document)
- Quick reference guide: External coordination, Ostlänken

Created by
[Created by]
Case number
[Case number]

Document date
[Document date]

Confidentiality level
[Confidentiality level]

- Quick Reference Guide Ebba
(Permissions, Edit_multiple_documents, search_view_documents, Reviewer, Delivery Manager, Project Registrar_Admin, Project Registrar_basic, Designer_work, Designer_order, Designer_submission)
- Product templates
(Cover page template, table of contents template, front cover template, spine template, GIS report template, drawing list template FU_BH, change memo template, name box Bentley MicroStation Design and Autodesk Design)

The Ostlänken Digital Project Management Plan states that the Contractor shall draw up an object-specific guide/project-specific digital project management plan; we wish to emphasise the importance of this document being produced very early in the assignment.

The Ostlänken Digital Project Management Plan sets out how the sharing and delivery of product documents are to be managed and reported in a separate delivery schedule. A draft delivery schedule is produced at the start of the project.

BIM – Building Information Model

The contractor shall, in consultation with the client, decide whether a coordination model is to be developed. The definition of a coordination model is set out in TDOK 2012:35 “Digital Project Management”.

Requirements for BIM in accordance with the Digital Project Management Plan, Ostlänken and its relevant appendices.

The contractor shall ensure that the correct level of BIM is selected and present this to the client. The choice of level regarding Level of Information (LOI) and Level of Detail (LOD) shall be selected to provide benefit, added value and cost-effectiveness in the project. Any cost-driving requirements from the client shall be challenged.

The level of BIM and modelling work shall be determined based on need, to facilitate the production of construction models and to achieve functional machine control. If what is produced does not provide added value to improve application in design and production, it shall not be produced. If BIM is to be designed to support cost predictability, the parties shall consult on this. The parties shall consult on the cost and benefits/added value of BIM prior to its implementation in the project.

At the start of the project, the contractor shall produce a draft model list. A draft model list refers to a list of all models, coordination models and subject area models to be created within the scope of the project (including those containing information on existing conditions). The list is drawn up to provide an overall picture of the scope of the project. For each model, detailed

The Ostlänken design plan sets out how work on the Model Report (RFM), Coordination Model Report (RFS) and Subject Area Model Report (RFA) is to be handled.

Created by
[Created by]
Case number
[Case number]

Document date
[Document date]

Confidentiality level
[Confidentiality level]

At the start of the assignment, the contractor shall, together with the client, determine whether existing coordination models need to be supplemented with existing conditions. A coordination model with existing conditions illustrates the baseline situation at the start of the assignment. Relevant information (including land, orthophotos, terrain, property information, buildings, place names and utility lines) must be included in the model. Associated subject area models must also be listed in the model inventory.

Model structure

The points below are a supplement to the Digital Project Management Plan for the East Link

Textual information such as place names, road names, railway names and lakes, other important locations, and other relevant information traditionally shown on a base map must be included. Text must be legible, oriented in the same direction and coordinated with other text that is to be visible at the same time.

An adapted terrain model is presented in thematic area models.

Follow-up

The parties shall agree on the frequency with which coordination and thematic area models are to be made available to the client for meetings concerning design and, where applicable, production.

The parties shall agree on how training and the use of the project's models are to be carried out.

The existing ground model shall be adapted to the designed area before the model is sent to the client with the review status/purpose "Approved".

The parties shall agree on the frequency of meetings regarding digital project management (data coordination, BIM, GIS)

GIS – Geographic Information System

The contractor shall ensure that the correct level/scope for GIS is selected and present this to the client.

The level/scope of GIS must provide added value/benefit for design and production, and the selected scope must be cost-effective. Cost-driving requirements from the client must be challenged.

The parties shall consult on the cost and benefits/added value of GIS prior to its implementation in the project.

X. Documentation/Approval Process

The relevant subject areas within the railway facility shall provide supporting documentation to the client for the approval process.

XB. Design Specification

The contractor shall draw up a general description of how the design and construction of the facility are to be planned, carried out and documented.

Created by
[Created by]
Case number
[Case number]

Document date
[Document date]

Confidentiality level
[Confidentiality level]

The description must set out specific measures, methods and procedures, as well as the expertise involved during the design and construction phases. Critical factors and stages, as well as serious or significant risks, must be described. The content must be structured in such a way that the client can make an informed assessment of the planned execution and results.

A preliminary proposed bill of quantities for the construction documents shall be included in the design description.

The design specification shall be drawn up in close consultation with the Client, with regular sharing of working materials and joint working meetings. The design specification may be drawn up in sections according to the planned work. The purpose of the design specification is to describe the “design basis” and to set out the parameters and choice of methods that have formed the basis for the technical solution.

The Contractor shall present and explain the Design Specification to the Client verbally at a meeting held in conjunction with the delivery of the Design Specification.

XB. Design Specification / Bridges and bridge-like structures

The contractor shall draw up a design specification for each part of the works that corresponds to what is described in TRVINFRA-00226, Chapter 5.3.2, as a report on the basic design and execution (RPUU).

XC. Construction documents

The purpose of the requirements under Construction Documentation is to provide guidance on content; the contractor is free to choose how to structure the Construction Documentation according to their needs.

The construction documentation must contain the necessary documents required for production and to demonstrate/verify that all requirements, functions and constructability are met, as well as at least detailing the management data.

When producing construction documents, coordination is required with the technical disciplines designed by the client’s external consultant in accordance with the chapter below. It must be ensured that no conflicts or interface issues arise during the design phase that affect the construction documents.

Deviations, additions or other changes in relation to existing boundaries must be shown on the floor plan and the subject area model for boundaries.

Deviations from standards, guidelines, policy documents and technical manuals must be reported to the client for approval.

Work plans must be drawn up for high-risk and critical stages. There must be a clear link from serious/significant risks to control programmes with associated control plans and down to work plans.

Calculations must be presented in such a way that they can be traced from input data to calculation results and are easy to follow. All calculations and their results must be identifiable.

Control programmes with associated control plans must have a separate section for checks required for risk management and to ensure that environmental and health and safety requirements are met. Separate sections must also be drawn up for design (planning) and execution (construction).

Created by
[Created by]
Case number
[Case number]

Document date
[Document date]

Confidentiality level
[Confidentiality level]

The client shall check and approve the contractor's prepared construction documents before construction may commence. The Swedish Transport Administration shall notify the contractor of its comments within 15 days of receipt, unless otherwise specified in a specific TDOK/TRVinfra/technical area or other agreement.

Work may only be carried out in accordance with the approved construction documents.

The construction documents approved by the contractor shall be delivered, together with associated working files in exchange format and configuration files in original format, to the Swedish Transport Administration's document management system as specified in the Ostlänken digital project management plan.

Construction documents consist of material and work specifications, a coordination model with associated subject area models, drawings, calculations, technical memoranda, work preparations, surveys and inspection programmes with associated inspection plans. Work specifications must be linked to serious/significant risks.

Construction documents shall also include:

- A complete list of documents.
- Detailed drawings and documents for each system and the facility as a whole.
- List of drawing and model files for the technical areas that have drawings/models.

XC. Construction documentation/Drainage/Water and sewerage

Construction documents shall include:

- Plan drawings, profile drawings, section drawings and detail drawings as specified below.
- PM.

Plan drawings shall show:

- All components of the drainage system.
- Pipes, wells and culverts, including dimensions, materials, water flow rates and connections, as well as the levels of the top of the well covers.
- Ditches and ponds must be shown with elevations and dimensions
- List of wells
- Any dismantling must be shown on a separate drawing

Detailed drawings (e.g. 1:50 or 1:20) must be produced for particularly complex sections, e.g. sampling wells, culvert-slope transitions in stormwater ponds.

For retention facilities/ponds, a plan, section and longitudinal profile must be produced, detailing the facility's constituent parts and function. Service roads and parking areas for service vehicles must be shown.

The memorandum shall contain:

- A description of the site conditions and existing drainage facilities.

Created by
[Created by]
Case number
[Case number]

Document date
[Document date]

Confidentiality level
[Confidentiality level]

- A presentation of catchment areas with receiving water bodies in plan drawings. Sub-catchment areas for facilities must also be shown, together with the outlet point of the drainage facility. Low points and confined areas must be indicated, as well as the surface from which the stormwater is diverted and its destination.
- Choice of method and description for calculating design stormwater flows and through-flow rates. Presentation of catchment areas including sizes, land uses, selected runoff coefficients, run-off times and return periods, as well as design stormwater flows, etc. Choice of method for design. Report on dimensions and verification of capacity.
- Choice of method and description for flow and storm water calculations, as well as a report on design flows/water levels and compliance with requirements.
- Technical details regarding the respective land drainage companies.
- Any impact on the respective land drainage schemes and any retention requirements. Choice of method and description of flow calculations and retention requirements.
- References to current drawings and surveys, as well as other relevant documents produced within the project.
- Report on selected technical solutions, including a description of drainage conditions and measures.
- Report on culverts, pipes and reservoirs requiring reinforced foundations, and the measures required.
- Report on flow rates and how discharge requirements/flow requirements are met at discharge points.
- Report on pressure levels.
- Description of the outlet's function in frost, frozen conditions and ice.
- Report on property boundaries, description of ownership and responsibility at the end points/discharge points of the drainage system.
- Design calculations for internal and external water pressures in reservoirs, stormwater reservoirs and sealed ditches.
- Any special investigations and a report on treatment requirements.

XC. Construction documents/Rock engineering

Construction documents shall include:

- Work plans for blasting operations. The work plan must specify how the blasting operations take into account the applicable risk analysis.
- Blasting plans. The blasting plans shall contain information on: hole dimensions, hole placement, hole depth, types and dimensions of explosives, charge concentrations, charge quantity per hole, estimated maximum combined charge, firing sequence and interval numbers.
- Selected technical solutions, including a description of the rock engineering conditions, calculations, measures, implementation and inspection/verification.
- Selected technical solution for rock excavation that meets the specified requirements.
- For rock slopes, the requirements of TRVINFRA-00230 must also be taken into account in the design report.

Created by
[Created by]
Case number
[Case number]

Document date
[Document date]

Confidentiality level
[Confidentiality level]

XC. Construction documents / Bridges and bridge-like structures

The contractor shall prepare a design report for bridges and bridge-like structures in accordance with TRVINFRA-00226, Chapter 5.4.1.

The contractor shall prepare a design report for each part of the works in accordance with TRVINFRA-00226, Chapters 5.4.6–5.4.9.

The design report referred to above shall be sent to the Swedish Transport Administration for review in accordance with the agreed design schedule and must be approved by the Swedish Transport Administration before construction of the structure commences.

Submission of matters for review shall be carried out in accordance with the project-specific procedure described at the design kick-off meeting.

The Swedish Transport Administration's review of the design report for documents is set out in TRVINFRA-00226, Chapter 5.3.3.

XC. Construction Documents / Geodetic Surveying

Construction documentation shall include at least:

- MätR in accordance with OTB-mät, TLS4110-20GD-052-30-0_0-0001
- Report on completed control networks in plan and elevation, as well as the control networks the contractor intends to carry out during construction
- Report on the ground model forming the basis of the construction documentation. The accuracy achieved must be verified and reported. Any additions made must be reported. Any deficiencies in the documentation provided must be reported.
- Report on the setting-out/control method to meet the tolerances in the geometry of the structure/construction that ensure intended function and service life.

XC. Construction Drawings/Geotechnics

The contractor shall, for each part of the works, draw up a design report and construction documents that meet the requirements set out in "Requirements for Geotechnical Structures".

The Client's review of the design report and construction documents shall be in accordance with the provisions of "Requirements for Geotechnical Structures".

Any supplementary investigations carried out within the scope of the contract shall be reported in accordance with the Swedish Transport Administration's template "Geotechnical Investigation Report, Geotechnics". The investigations shall be reported in accordance with the SGF's designation system.

Construction documents shall include:

- selected technical solutions with a description of geotechnical conditions, calculations, measures, execution and inspection/verification.

Created by
[Created by]
Case number
[Case number]

Document date
[Document date]

Confidentiality level
[Confidentiality level]

- Geotechnical investigations and materials reported in the tender documentation shall be reported in conjunction with the supplementary investigations carried out during the contract and with updates to the road or railway structure designed by the contractor. The investigations shall be reported in accordance with standard practice based on the Swedish Geotechnical Society's designation system.
- document for inspection and monitoring, in which, among other things, critical geotechnical aspects and checks shall be described. The document may be divided into sections for individual parts of the works or road structure/railway structure/building works
- The results of stability and settlement calculations, as well as other geotechnical design calculations, shall be reported to the extent necessary to demonstrate that the requirements for stability, settlement and other aspects in accordance with TK Geo have been met. The calculations shall be presented in such a way that they can be traced from the input data (results of geotechnical investigations) to the calculation results and any measures resulting therefrom. The results shall be compiled in a separate Design Memorandum and sent to the client upon delivery for acceptance inspection. The calculations shall be easy to follow. All calculation pages, tables and diagrams shall be identifiable. Calculated sections shall be identified by object name, length measurement or similar.

Geotechnical calculations shall be reported as follows:

- measured and empirically derived strength values shall be compiled for the relevant sub-areas, after which derived, characteristic and design strength values shall be specified.
- Results from the calculations carried out shall be presented graphically, showing design parameters such as ground levels, structures, loads, etc., as well as the most critical slip surface(s) and safety factor(s).
- Calculations shall be performed and presented in such a way that both local and overall stability are taken into account. The calculations shall be performed for existing conditions, after development (with and without reinforcement measures) and for critical construction stages.
- In conjunction with stability calculations, the presence and extent of particularly sensitive soil layers and water conditions (e.g. quick clay, sulphide soil, peat, water-bearing layers, artesian pressure, design water levels in watercourses) shall be taken into account and reported.
- Settlement calculations shall be reported using the design assumptions for settlement calculations, with stress diagrams specifying geotechnical parameters and selected properties, as well as a report on the calculated settlement and its time history for both the proposed reinforcement measure and without a reinforcement measure
- Settlement calculations must be presented with and without creep, and taking into account ongoing settlement and existing structures
- The computer software used, including version numbers, must be specified.

XC. Construction Documentation / Hydrogeology

Field and laboratory investigations carried out within the scope of the contract shall be reported in accordance with the Swedish Transport Administration's template "Geotechnical Investigation Report". The investigations shall be reported in accordance with the SGF's designation system. Hydrogeological investigations and materials reported in the tender documentation shall be reported together with the supplementary investigations carried out within the contract.

Reports on installed groundwater pipes (observation pipes) and pump wells must include, as a minimum, details of the groundwater aquifer (rock, soil and upper or lower aquifers), installation method, location (coordinates, pipe top elevation and ground level), total pipe length, filter length, filter type,

Created by
[Created by]
Case number
[Case number]

Document date
[Document date]

Confidentiality level
[Confidentiality level]

filter level, diameter and pipe material. Functional testing of installed groundwater pipes (observation pipes) must be reported.

The results of test pumping shall indicate the capacity of the extraction well and the properties of the aquifer (transmissivity, hydraulic conductivity and aquifer coefficient, where applicable). The evaluation of hydraulic tests shall be reported in such a way that it can be traced from input data to calculation results and any measures taken as a result. The results shall be compiled in a separate Design Memorandum on Hydrogeology and forwarded to the client.

The construction documents shall otherwise include at least:

- A report on the selected technical solutions relating to groundwater or hydrogeological measures, and their implementation, how these meet requirements relating to groundwater, and how functional checks are to be carried out. The report shall be presented per hydrogeological unit and may be divided into several reports. A hydrogeological unit may, for example, be the impermeability of a retaining structure, a geographically defined geological formation, or the performance of hydraulic tests. The report shall contain a description of hydrogeological conditions, calculations, type of measures, work execution, work schedule (e.g. phasing) and checks/verification.
- Report on minimum drainage levels, characteristic groundwater levels and design groundwater levels. The report shall include descriptions of the background data used and reasoning regarding assumptions and uncertainties in the calculation so that the proposed values can be reviewed.
- Risk assessment and contingency plan with an account of planned impacts, critical levels and risk objects.
- A description of how watertightness tests on retaining structures/sheeting are to be carried out, how measurements of groundwater ingress at excavation sites are to be conducted, and the estimated accuracy of this flow rate.
- Report on well design, well installation and functional testing of extraction and infiltration wells.

XC. Construction documents/Component ID, roads

Construction documents for roads shall specify unique component IDs for installation components in accordance with "TDOK 2012:1171 System numbers and component designations", TRVINFRA-00234 "Marking of road operational environment – Requirements" and TDOK 2019:0210 "Data and documentation for management systems – Roads".

XC. Construction documentation/Landscape and design

The construction documentation shall include a description of materials and colours.

The construction documentation shall describe the design of bridges, junctions between different types of barriers (e.g. noise barriers and fencing) and terrain design.

The construction documentation shall describe soil management and land restoration.

XC. Construction Documents/Utility Coordination

Each utility owner shall produce their own construction documents for their own new installations and relocations affected by the contract.

Created by
[Created by]
Case number
[Case number]

Document date
[Document date]

Confidentiality level
[Confidentiality level]

Coordination of construction documents shall be carried out by the contractor and shall cover the location of the utility route, status (new or existing), dimensions, number of pipes, type, colour, owner and what they are intended to serve.

XC. Construction documents/Land

Construction drawings shall include:

- Dimensioned standard cross-sections for the railway infrastructure and its adjacent areas must be provided. The scale must be 1:50. Standard cross-sections must show:
 - Layer thicknesses and selected materials/technical specifications
 - Documents detailing inspection and monitoring
 - Construction of the pressure bench, including technical specifications and foundations
 - Construction of noise barriers, including technical specifications and foundations
 - Construction of the noise barrier, including the junction between the barrier and the embankment
- Site plans for the railway facility on a scale of 1:500. The site plans must show:
 - Property boundaries
 - Railway alignment boundaries
 - Planned embankments
 - Fences, barriers, gates
 - Noise barriers
 - Elevated noise barriers
 - Pressure banks

XC. Construction documents/Soil management plan

The construction documents must include a project-specific earthworks management plan detailing the handling of all earthworks within the contract, from sampling, classification, excavation, storage, transport and final disposal, as well as reporting and documentation. The plan must be approved by the client prior to the start of construction.

The earthworks management plan shall cover:

- How materials to be reused in the project will be handled, stored and returned
- How surplus materials will be managed, stored and removed, as well as who the final recipient is and how it is ensured that the recipient holds the necessary permits
- How contaminated materials are to be handled, stored and removed or reused, who the final recipient is, and how it is ensured that the recipient holds the necessary permits
- Transport routes

XC. Construction documents/Environment

Construction documentation shall include:

Created by
[Created by]
Case number
[Case number]

Document date
[Document date]

Confidentiality level
[Confidentiality level]

- Wildlife crossings in water, the facility in relation to water levels (LLW, MW and HHW), the width and bottom level of watercourses, bottom structure, terrain adaptation, erosion protection, guiding structures, etc.)
- Wildlife crossings on land, width/height of crossing, surface layer and thickness of soil layers, terrain adaptation, guiding structures, planting, etc.
- Exits, technical design, location and adaptation to the terrain
- Protective measures for ancient monuments and buildings of cultural heritage value must be marked on the site plan.
- Documentation of investigations into contaminated soil in accordance with SGF Report 2:2013.

XC. Construction documents / Road design

Construction documents shall include:

Standard cross-sections for all roads included.

XC. Construction documents/Road design

Construction documents shall include:

- a description of the roads' geometry in plan and profile
- standard cross-sections for all components of the road scheme and its verges
- design regarding scope, location, camber, fixings, etc. of safety and road equipment in the lateral and longitudinal directions
- a profile with elevation marks at least every 10 metres, also showing cross-slope, skew, skew transitions, gradients, vertical radii and break points
- level optimisation at grade-separated junctions with regard to the final design height of bridges
- additions such as road signs, kerb posts, road markings and kerbs.

XD. Final documentation

A digital project management plan with associated regulations describes how final documentation of project documents and management data is to be handled.

XD1. BIM – Building Information Model

The coordination model shall show how the facility is constructed, with all deviations, changes and as-built measurements from the construction documents incorporated as as-built documentation.

The coordination model and associated subject area models must be delivered with the relevant configuration files in accordance with the model specification, RFM to Chaos or to ProjectWise (PDBI).

Survey data in accordance with measurement requirements shall be presented as a separate model and displayed in the coordination model

XD2. Basis for the design documentation

Created by
[Created by]
Case number
[Case number]

Document date
[Document date]

Confidentiality level
[Confidentiality level]

Construction documentation for track, electrical, signalling, telecommunications and ducting is produced by the Client's external consultant. The TLS contractor's remit includes preparing the basis for the coordination document for track, electrical, signalling, telecommunications and ducting, on which the Client's external consultant prepares management data.

XD2. As-built drawings

The as-built drawings must correspond to the actual construction and function and must depict the facility in its entirety. The as-built drawings must show what the facility looks like when it is put into service. The as-built drawings must, among other things, serve as a basis for the Client's monitoring during the warranty period, as a basis for future refurbishment and as a basis for management data.

The as-built documentation shall be delivered as a complete product document in accordance with TDOK 2023:0080 "Instructions for the sharing and delivery of product documents, Ostlänken".

The as-built documentation for the facility shall document locations, dimensions, materials used, measured functional properties, finishes and inspections, including calculations, drawings and descriptions.

Deviations, additions or other changes to the Construction Documentation must be documented.

Ground surfaces outside the worksite where the elevation has changed during the contract shall be surveyed and included in the ground model.

The contractor shall, for all works, i.e. materials, condition, execution and inspection covered by AMA, draw up descriptions with codes and headings in accordance with AMA.

All items present in the facility that are listed in "SIS Construction Documents" shall be reported in the as-built documentation.

Minutes, test certificates, product verifications, measurements and product declarations shall be included in the as-built documentation.

Reports from preliminary inspections/final inspections shall be included in the as-built documentation. As-built documentation shall be listed, dated and signed by the contractor.

Relationship documents must be checked and approved by the Swedish Transport Administration. The timing of the Swedish Transport Administration's inspection shall be in accordance with the agreed project schedule.

XD2. Project documentation/Railway infrastructure

All objects occurring in the facility that are listed in TDOK 2019:0215 "Data on the facility – Coding of geographical objects – Railway" shall be reported in the as-built documentation.

The contractor shall propose a folder structure for the relationship documentation in accordance with TDOK 2023:0080. The folder structure, including subfolders, is presented in TMALL 0406 and must be accepted by the client.

XD2. As-built documentation/Road construction

The as-built drawings shall, as a minimum, comprise and be based on the construction documents drawn up in accordance with Section XC. Construction documents/Road design.

Created by
[Created by]
Case number
[Case number]

Document date
[Document date]

Confidentiality level
[Confidentiality level]

As-built drawings for construction shall document the technical solution implemented as described and presented in the construction documents; see Section XC. Deviations, additions or other changes to the construction documents shall be documented continuously and surveyed in plan and elevation. These documents, verified and revised on the basis of deviations, additions or other changes, shall serve as as-built drawings.

The as-built documents shall include:

- Road and profile geometries, road edges, safety and road installations, and other boundaries (surfaces) within the traffic area shall be geodetically surveyed and reported as objects and continuous lines with coordinates (x, y, z) at intervals of 5–20 m, depending on the geometry.
- The final road area to be utilised, which shall be reported in conjunction with the established road area. The final road area utilised shall be reported as a 3D polyline.
- The final position of any fences, gates, escape routes, etc. must be shown.

XD2. As-built drawings/Drainage/Water and sewerage

All components of the drainage system must be included in the relationship documentation, such as drainage pipes, drainage pipe manholes, stormwater pipes, stormwater pipe manholes, ditches, pumping stations, stormwater storage basins, open stormwater facilities, soil filters, floodplains, culverts, protective pipes and manholes on protective pipes, connections, valve chambers and meter chambers. Devices in drainage systems such as, for example, shut-off devices, grates, cathodic protection, devices for specific functions in ditches, thermal insulation, frost protection cables, flow-restricting devices and flow-restricting fillings shall be included. Repairs and renovations carried out shall be included. Measures taken on parts of the drainage system that have been taken out of service or demolished shall be included.

A list of all wells must be produced.

Break points and end points on pipelines and ditches must be reported. Pipe dimensions, pipe type, pipe material, pressure class, strength class, special jointing methods, and materials used during installation or renovation must be included.

Test reports in accordance with the description in Svenskt Vatten P91.

Documentation for dams and reservoirs must include:

- Catchment area.

XD2. Design documentation/Rock

For rock slopes steeper than 1:1, the crest and toe of the slope must be surveyed. The start and end of the cut must also be coordinate-determined in the national map projection SWEREF 99 TM.

Documentation of slopes shall be carried out in accordance with TDOK 2023:0199 “Engineering geological mapping”.

Created by
[Created by]
Case number
[Case number]

Document date
[Document date]

Confidentiality level
[Confidentiality level]

Design calculations for rock reinforcement must be reported.

Newly constructed rock cuttings and associated documents must be registered in BaTman in accordance with TDOK 2019:0210, "Requirements for Data and Documentation for Management Systems – Roads".

The relationship document must be sent to the National Maintenance Building Works (UHNby).

XD2. Handover document / Bridges and bridge-like structures

The contractor shall draw up handover documents for each part of the works. These shall include a structural report in accordance with TRVINFRA-00226, Chapter 5.4.10.

The contractor shall carry out a main inspection of the structures, which shall be recorded in BaTMan.

XD2. As-built drawings/Geodetic surveying

The execution and results of the assignment shall be compiled in a surveying report, MätR, in accordance with OTB-mät, TLS4110-20GD-052-30-0_0-0001. The MätR shall be signed by the person responsible for surveying works.

XD2. As-built drawings/Geotechnics

The contractor shall draw up handover documents that meet the requirements set out in "Requirements for Geotechnical Works, Administrative Rules".

The as-built documentation must be delivered to ProjectWise no later than three months prior to commissioning. Any temporary geotechnical structures left in place (e.g. cut sheet piling) must also be included in the as-built documentation.

The as-built documentation shall include:

- A report on field and laboratory investigations carried out in accordance with the Swedish Transport Administration's template "Geotechnical Investigation Report, Geotechnics".
- All field and laboratory investigations must be transferred in digital form to the client in SGF's standard format for field data, or alternatively in Geosuite format. This is transferred digitally to the Swedish Transport Administration's geotechnical database via Geosuite Toolbox using the Sweref TM coordinate system. The Field Test Report and Laboratory Test Report must be attached as accompanying reports.

XD2. Relationship Document / Hydrogeology

The documentation must include:

- A report on field and laboratory investigations carried out in accordance with the Swedish Transport Administration's template "Geotechnical Investigation Report, Geotechnics".
- All field and laboratory investigations must be transferred in digital form to the client in SGF's standard format for field data, or alternatively in AutoGraf format. This is transferred digitally to the Swedish Transport Administration's geotechnical database via Geosuite Toolbox and to ProjectWise using

Created by
[Created by]
Case number
[Case number]

Document date
[Document date]

Confidentiality level
[Confidentiality level]

the Sweref TM coordinate system. The Field Test Report and Laboratory Test Report shall be attached as accompanying reports.

- All groundwater pipes, wells and groundwater level measurements carried out within the contract shall be transferred in digital form to the client in a format readable by the Swedish Transport Administration's database. A template for data delivery shall be provided by the client.
- Technical descriptions, calculation appendices and construction drawings relating to measures concerning hydrogeology.
- A list summarising the hydrogeological measures carried out in connection with the length measurement, with references to the relevant as-built drawings and documents.

XD2. As-built documentation / Landscape and design

Relationship documents for landscape and design issues are covered by relationship documents for other parts of the works; however, the relationship documents drawn up must include points from code XC. Construction documents/Landscape and Design.

XD2. Coordination Document/Environment

The coordination document shall include:

- noise barriers (plan, section and profile drawings showing height, length, distance to the design level/RÖK, and adaptation to the terrain)
- wildlife crossings in water (plan and elevation in relation to water levels (LLW, MW and HHW), width and bottom level of watercourses, bottom structure, adaptation to terrain, erosion protection, guide structures, etc.)
- fauna passages on land (plan, section and profile drawings showing: width/height of the passage, surface layer and thickness of soil layers, adaptation to terrain, guiding structures, planting, etc.)
- detailed drawings showing technical design and a plan showing location
- water management facilities (dimensioning, calculations and plan and detail drawings showing technical design)
- surface and groundwater protection (dimensioning, calculations and plan and detailed drawings showing technical design)
- Report on the reuse of contaminated soil (drawings and documentation showing origin/content, location and extent)

Created by
[Created by]
Case number
[Case number]

Document date
[Document date]

Confidentiality level
[Confidentiality level]

XD3. Management data/environment

The contractor shall, at the start of the design phase, appoint a person responsible for management data. Management data shall be prepared in consultation with the client and delivered continuously in accordance with a delivery schedule drawn up on the basis of the TMALL specified below

XD3. Management data/Railway

The contractor shall prepare and, throughout the course of the project, deliver management data in accordance with delivery deadlines, in accordance with TDOK 2016:0407 "Data and documentation for management systems – Railways". See also TDOK 2016:0411 "Handling of data and documentation to/from management systems – Railways".

Management data is not included in the scope of work for track, power, signalling, telecommunications and ducting. This is to be produced by the Client's external consultant.

The Contractor shall list and deliver in accordance with the delivery schedule requirements in TMALL 0344 Management Data for Railways – Delivery Plan.

The positioning of location-specific construction data shall be based on an approved control network established in accordance with TDOK 2014:0571 "Geodetic Surveying and Geographical Positioning – Roads and Railways".

The coding of geographical objects shall comply with "TDOK 2019:0215 Coding of geographical objects – Railways".

Data for the BIS shall be prepared during the design phase and reported in accordance with delivery plan 0344. The BIS shall be updated and supplemented with regard to all relevant object types, including any existing objects in the BIS that are to be modified or removed. The contractor shall prepare and deliver complete documentation (Excel) for updating the BIS. Checklists and templates for reporting new and modified objects in the BIS are available for download on the Swedish Transport Administration's website,

XD3. Management data/Railway/Power supply facility

Management data and delivery schedules must be checked and approved by the Swedish Transport Administration.

Updates to diagrams must be carried out in accordance with TRVINFRA-00162 "Updating of connection diagrams and group diagrams for the Swedish Transport Administration's contact and auxiliary power line installations", Chapter 6 "Workflow". Updating of connection diagrams and group diagrams for the Swedish Transport Administration's contact and auxiliary power line installations. The TLS Contractor assumes responsibility for all work tasks and ensures that all work stages are completed.

XD3. Management data/Road

The Contractor shall prepare and, throughout the course of the project, in accordance with delivery time requirements, deliver management data in accordance with TDOK 2019:0210 "Data on the facility – Data and documentation for management systems – Road".

The contractor shall list and deliver in accordance with the delivery schedule requirements "TMALL 0343 Data on the facility – Delivery plan – Road"

Management data and delivery plans shall be checked and approved by the Swedish Transport Administration.

Created by
[Created by]
Case number
[Case number]

Document date
[Document date]

Confidentiality level
[Confidentiality level]

XD3. Management data/Component ID, road

To be delivered in accordance with Chapter 5 of TDOK 2019:0210 with the following additions and clarifications: Completed template TMALL 0742 (one per facility and technology type)
Completed scrap template TMALL 0742 (one per facility and technology type).

XD3. Management data/Environment

Handover report for the environment in accordance with TMALL 0173

Documentation for the regional environmental website. The following templates specify how reporting is to be carried out:

- TDOK 2023:0149 Regional Environmental Web – Avenue
- TDOK 2023:0150 Regional Environmental Web – Species-rich railway environment
- TDOK 2023:0158 Environmental Web Landscape – Solitary Trees
- TDOK 2023:0153 Environmental Web Landscape – Wildlife crossing for medium-sized mammals
- TDOK 2023:0160 Miljöwebb Landscape – Aquatic wildlife crossing
- TDOK 2023:0159 Environmental Web Landscape – Stone wall
- TDOK 2023:0154 Environment Web Landscape – Wildlife crossing for large mammals
- TDOK 2023:0162 Environment Web Landscape – Other environmental feature
- TDOK 2023:0157 Environmental Web Landscape – Heritage Trail
- TDOK 2023:0161 Environmental Web Landscape – Road-related cultural heritage

Other systems:

- TMALL 0188 Import to project hub regarding noise protection measures.
- TMALL 0006 List of contaminated sites for input into LEB
- TMALL 0731 List of surface and groundwater protection measures for railways

Measurement/analysis data for emission control, such as water quality, water flow, groundwater data and results of noise and settlement measurements. To the extent that the project stores data in a database, the project shall provide information on this.

XD4. Operation and maintenance plan

Operational and maintenance plans shall be drawn up for preventive and corrective maintenance of all structures, equipment and systems at the facility.

An operation and maintenance plan shall be drawn up for the facility, describing the quality-critical operation and maintenance work required for the facility to function in accordance with the specified requirements throughout its technical service life, and setting out any restrictions on implementation.

Operations and maintenance plans drawn up must specify which environmental functions are to be maintained and how.

The folder structure containing the Operation and Maintenance Plan must be approved by the Swedish Transport Administration.

Created by
[Created by]
Case number
[Case number]

Document date
[Document date]

Confidentiality level
[Confidentiality level]

Operation and maintenance plans must be delivered to the project's system for the delivery of product documents in accordance with the Digital Project Management Plan, as well as to the management systems specified in the regulations for management data as set out in this document.

XD4. Operation and Maintenance Plan / Drainage

The Operation and Maintenance Plan shall cover facilities for pumping stations, stormwater ponds, stormwater reservoirs, open stormwater facilities, soil filters, overflow areas, stormwater treatment plants, facilities with screens and other facilities with specific operational and maintenance requirements.

The operation and maintenance plan shall include:

- dimensioning
- operating instructions
- maintenance instructions
- catchment area, potentially contaminated surfaces, paved surfaces
- how cleaning is to be carried out
- vehicles required for maintenance
- design of any erosion protection
- shutdown
- how water flows before and after closure of the facility
- alarms, electrical and communication equipment for control
- selected impermeability of the stormwater storage tank up to the design level
- method for checking watertightness

XD4. Operation and maintenance plan / Bridges and bridge-like structures

To be drawn up in accordance with TRVINFRA-00226.

XD4. Operation and maintenance plan/Landscape and design

Maintenance plans for vegetation areas must be in place upon handover of maintenance to the client.

The contractor shall draw up maintenance plans for plant beds and vegetation areas for both during and after the warranty period.

The Swedish Transport Administration's publication "Vegetation in the Road Environment, Practical Advice", the chapter on construction documentation and other applicable sections, shall form the basis for the work on vegetation establishment and maintenance.

The folder structure containing the Operation and Maintenance Plan must be approved by the client.

XD4. Operation and Maintenance Plan/Environment

Created by
[Created by]
Case number
[Case number]

Document date
[Document date]

Confidentiality level
[Confidentiality level]

A plan for the control and management of invasive alien species during the warranty period shall be drawn up. The plan shall, among other things, describe how an annual on-site inspection is to be carried out together with a representative of the client and other relevant parties.

For acoustic elements in noise barriers, the manufacturer/supplier shall provide a declaration of performance, installation instructions and maintenance instructions.

Created by
[Created by]
Case number
[Case number]

Document date
[Document date]

Confidentiality level
[Confidentiality level]

List of referenced requirements documents.

The list contains the referenced requirements documents.

The list has been drawn up with references based on how the requirements documents are named in TB. Supplements and appendices belonging to the reference document must be documented in the list. All requirements documents referred to in TB's requirement texts must be included in this list. Those currently referred to in the advisory text are not included in the list and need to be added if they are cited.

The template's reference list is not exhaustive of all the requirements documents and other documents referred to. This is because the requirements must be adapted to the project, and consequently the scope of requirements documents and other documents will vary in each project.

Standards that are cited should not be listed in the list below. It is therefore important that the full text of the standard is included in the main text.

Links to search for the Swedish Transport Administration's policy and guidance documents.

<https://www.trafikverket.se/tjanster/publikationer-och-styrande-dokument/trafikverkets-styrande-dokument/>

<https://puben.trafikverket.se/>

Important!! This list must be updated for each individual project. Important!!

In the TB template, the requirements documents have been divided into three lists to make the template clearer. These can be merged into a single list in a TB if desired. If requirements documents are needed under other sections of the TB, e.g. V. External design, these must also be incorporated.

Created by
[Created by]
Case number
[Case number]

Document date
[Document date]

Confidentiality level
[Confidentiality level]

List A. Common requirements, X. Documentation and common requirements documents (D and F).

Designation in FB	Document ID	Title
AMA Installation		AMA Facility 23
AMA Electrical		AMA Electrical 22
Construction Documents 90 Part 7		Construction Documents 90 Part 7 Reporting on Construction, Edition 2
“Requirements for Geodetic Surveying and Geographical Positioning”	TDOK 2014:0571	Geodetic surveying and geographical positioning – Roads and railways, version 5.0
“Requirements TK Drainage”	TDOK 2014:0045	Requirements: The Swedish Transport Administration’s technical requirements for drainage – TK Drainage, version 2.0
“Guidance TR Drainage”	TDOK 2014:0046	Guidance Swedish Transport Administration’s technical requirements for drainage – TK Drainage, version 3.0
“MB 310”	TDOK 2014:0051	Technical dimensioning and design of drainage systems – MB 310, version 3.0
“TRVINFRA-00231”	TRVINFRA-00231	Requirements for Drainage, Design and Layout, version 3.0
“Publication: Surface and Groundwater Protection”	Publication 2020:171	Surface and Groundwater Protection – Methodology for Risk Management and Risk Analysis, and Principles for the Selection of Measures

Created by
[Created by]
Case number
[Case number]

Document date
[Document date]

Confidentiality level
[Confidentiality level]

Designation in FB	Document ID	Title
SIS-TS 21144:2016		Technical Specification SIS-TS 21144:2013 Construction surveying – Specifications for the production and verification of digital terrain models
TDOK 2012:35 “Digital project management”	TDOK 2012:35	Digital project management, version 9.0
TRVINFRA-00145 “LED luminaires – Requirements”	TRVINFRA-00145	Requirements for LED luminaires, version 2.0
NMF01:2021	NMF01:2021	Technical specification. LED luminaires – requirements. (NMF = Nordic Meeting for Improved Road Equipment)
“Requirements for bridges and bridge-like structures, General requirements”	TRVINFRA-00226	Requirements for bridges and bridge-like structures, General requirements, version 5.0
“Requirements for bridges and bridge-like structures, Construction”	TRVINFRA-00227	Requirements for Bridges and Bridge-like Structures, Construction, version 5.0
“Requirements for Bridges and Bridge-like Structures, Bridge Maintenance”	TRVINFRA-00228	Requirements for Bridges and Bridge-like Structures, Bridge Maintenance, version 6.0
“Requirements for Geotechnical Engineering, Administrative Rules”	TRVINFRA-00229	Requirements for Geotechnical Engineering, Administrative Rules, version 2.0

Created by
[Created by]
Case number
[Case number]

Document date
[Document date]

Confidentiality level
[Confidentiality level]

Designation in FB	Document ID	Title
“Requirements for Geotechnical Engineering, Dimensioning and Design”	TRVINFRA-00230	Requirements for Geotechnical Engineering, Dimensioning and Design, version 3.0
TDOK 2015:0223 “Electrical safety instructions for work on or near railway-related high-voltage and train heating installations”	TDOK 2015:0223	Electrical safety instructions for work on or near railway-related high-voltage and train heating installations, version 7.0
“TRV AMA Installation”	TDOK 2023:0125	The Swedish Transport Administration’s amendments and additions to AMA Installation 23, version 3.0
“TRV AMA Electricity”	TDOK 2022:0324	The Swedish Transport Administration’s amendments and additions to AMA EI 22, version 5.0
“SGF Report 2:2013”		Field Manual: Investigations of Contaminated Sites (SGF Report 2:2013)
“Object-Oriented Information Model”	TDOK 2015:0181	Object-Oriented Information Model version 4.0
“Requirements – Cable Systems. Cable Removal”	TRVINFRA-00348	Requirements – Cable systems. Cable removal, version 1.0
“EBR Handbook KJ 41:21 Cable laying, max 145 kV”	EBR KJ 41:21	“EBR Handbook KJ 41:21 Cable laying up to 145 kV” published in 2021 (Svensk Energi – Swedenergy AB)
TDOK 2018:0198 “Managing managing electricity accounts”	TDOK 2018:0198	Procedure description – Managing electricity subscriptions, version 3.0

Created by
[Created by]
Case number
[Case number]

Document date
[Document date]

Confidentiality level
[Confidentiality level]

Name in FB	Document ID	Title
"TRVK Apv"	TDOK 2012:86	TRK Apv, Swedish Transport Administration's technical requirements for road works, version 5.0

Created by
[Created by]
Case number
[Case number]

Document date
[Document date]

Confidentiality level
[Confidentiality level]

List D. Roads

Designation in TB	Document ID	Title
“Design and construction of private roads”.	Publication 2020:089	Design and construction of private roads. Version 2.0
“Swedish Forest Agency, Guidelines for the design and construction of Class III and IV forest roads”		Swedish Forest Agency, Guidelines for the design and construction of Class III and IV forest roads
“Utility works within the state road network”	Publication 2022:129	Management work in the state road sector, version 1.0
TDOK 2013:0461 “Verification of longitudinal road markings by vehicle”	TDOK 2013:0461	Inspection measurement of longitudinal road markings by car, version 2.0
TDOK 2013:0580 “Electrical power installations. Control systems for road lighting installations”	TDOK 2013:0580	Electrical power installations. Control systems for road lighting installations, version 1.0
TDOK 2013:0462 “Handheld inspection measurement of longitudinal and transverse markings”	TDOK 2013:0462	Handheld inspection measurement of longitudinal and transverse markings, version 1.0
TDOK 2013:0669 “Inventory of frost-related damage to existing roads”	TDOK 2013:0669	Inventory of frost-related damage to existing roads, version 2.0
“TDOK 2014:0005”	TDOK 2014:0005	Road surface measurement – Objects, version 1.0

Created by
[Created by]
Case number
[Case number]

Document date
[Document date]

Confidentiality level
[Confidentiality level]

Designation in TB	Document ID	Title
“TDOK 2014:0151”	TDOK 2014:0151	Requirements – Sampling of unbound materials, version 1.0
TDOK 2014:0134 “Determination of friction on paved surfaces”	TDOK 2014:0134	Determination of friction on paved surfaces, version 3.0
“TDOK 2014:0136”	TDOK 2014:0136	Determination of unevenness and crossfall using a straightedge, version 1.0
TDOK 2019:0463	TDOK 2019:0463	Evaluation of the bearing capacity of road structures using a drop weight apparatus, version 1.0
“TRVMB 350”	Publication 2012:053	TRVMB 350 Guardrails – Classification, performance requirements for crash testing and test methods
“Requirements – VGU”	TRVINFRA-00396	Requirements – VGU, Road and Street Design, version 1.0
“VGU – Basic Values”	Publication 2024:148	Requirements Core Values: Road and Street Design Requirements, version 1.0
TRVINFRA-00224 Road Superstructure, Dimensioning and Design	TRVINFRA-00224	Road Superstructure, Dimensioning and Design, version 4.0
“VVMB 908”	Publication 1994:41	VVMB 908 Statistical acceptance control

Created by
[Created by]
Case number
[Case number]

Document date
[Document date]

Confidentiality level
[Confidentiality level]

Designation in TB	Document ID	Title
“System Numbers and Component Designations – Requirements”	TDOK 2012:1171	System Numbers and Component Designations – Requirements, version 9.0
TRVINFRA-00234 Marking in road operational environments	TRVINFRA-00234	Marking in the road operational environment – Requirements, version 4.0
Facility data – Data and documentation for management systems – Roads	TDOK 2019:0210	TDOK 2019:0210 Data on the facility – Data and documentation for management systems – Road, Requirements version 13.0
Lighting columns within the road area	TRVINFRA-00159	Lighting columns within the road area, version 1.0
Separation of bundled networks for road lighting	TDOK 2020:0259	Separation of bundled networks for road lighting, version 5.0
Control and monitoring Traffic control point	TRVINFRA-00258	Control and monitoring Traffic control centre, version 2.0
TRVINFRA-00264	TRVINFRA-00264	Control and monitoring Requirements for pump station control cabinets, version 1.0
“Bituminous layers, TDOK 2013:0529”	TDOK 2013:0529	Bituminous layers, version 4.0
“TDOK 2013:0530 Unbound layers for road structures”	TDOK 2013:0530	Unbound layers for road structures, version 3.0

Created by
[Created by]
Case number
[Case number]

Document date
[Document date]

Confidentiality level
[Confidentiality level]

List DH. Traffic management and site monitoring system

This list is linked to the standalone documents located in the folder DH. System for traffic management and construction supervision.

The documents are available at the Swedish Transport Administration in the workspace "TB template for TE" in a folder named "DH. System for traffic management and construction supervision.

Designation in TB	Document ID	Title
"TRVINFRA-00234 Requirements Labelling of road operations environment"	TRVINFRA-00234	Requirements for road operational environment signage, version 4.0
"TRVINFRA-00250 Requirements Equipment cabinets for road operations environment"	TRVINFRA-00250	Requirements for equipment cabinets in road operations environments, version 3.0
"TRVINFRA-00235 Requirements Documentation and review, road operations environment"	TRVINFRA-00235	Requirements Documentation and review of road operational environment, version 1.0
"TRVINFRA-00236 Requirements Inspection and testing of road operational environment"	TRVINFRA-00236	Requirements for inspection and testing of the road operational environment, version 2.0
"TRVINFRA-00237 Requirements Materials and workmanship in road operational environments"	TRVINFRA-00237	Requirements for materials and workmanship, version 3.0
"TRVINFRA-00247 Requirements Local control equipment road operational environment"	TRVINFRA-00247	Requirements Local control equipment road operational environment, version 1.0
"TRVINFRA-00244 Requirements Detector for road operational environment"	TRVINFRA-00244	Requirements Detector for road operational environment, version 3.0
"TRVINFRA-00258 Requirements Traffic control point"	TRVINFRA-00258	Requirements Traffic control point, version 2.0
"TRVINFRA-00260 Requirements HSWIM"	TRVINFRA-00260	Requirements HSWIM, version 2.0
"TRVINFRA-00262 Requirements Openable bridge"	TRVINFRA-00262	Requirements for openable bridges, version 2.0

Created by
[Created by]
Case number
[Case number]

Document date
[Document date]

Confidentiality level
[Confidentiality level]

Designation in TB	Document ID	Title
“TRVINFRA-00217 Requirements Road traffic signal systems”	TRVINFRA-00217	Requirements for Road Traffic Signalling Systems, version 3.0
“TRVINFRA-00218 Requirements Traffic signal lights road operational environment”	TRVINFRA-00218 v1.0	Requirements Traffic signal lights in a road operational environment, version 1.0
“TRVINFRA-00238 Requirements Training for road operations environment”	TRVINFRA-00238	Requirements Training for road operations environment, version 1.0
“TRVINFRA-00252 Requirements Variable message sign road operations environment”	TRVINFRA-00252	Requirements Variable message sign for road operations environment, version 2.0
“TRVINFRA-00239 Requirements Integration TUS”	TRVINFRA-00239	Requirements Integration TUS, version 2.0
“TRVINFRA-00240 Requirements Integration UMS”	TRVINFRA-00240	Requirements for UMS Integration, version 2.0
“TRVINFRA-00241 Requirements Integration ÖTS”	TRVINFRA-00241	Requirements for ÖTS Integration, version 1.0
“TRVINFRA-00255 Requirements Bus traffic lights – road operations environment”	TRVINFRA-00255	Requirements for bus traffic lights in a road operational environment, version 1.0
“TRVINFRA-00253 Requirements Traffic information display road operational environment”	TRVINFRA-00253	Requirements Traffic information sign, road operational environment, version 2.0
“TRVINFRA-00251 Requirements Automatic road closure device, road operational environment”	TRVINFRA-00251	Requirements Automatic road closure device for road operations environment, version 3.0
“TRVINFRA-00249 Requirements Alarms and incident management in road operations environment”	TRVINFRA-00249	Requirements for Alarms and Event Management in Road Operations Environment, version 1.0

Created by
[Created by]
Case number
[Case number]

Document date
[Document date]

Confidentiality level
[Confidentiality level]

Designation in TB	Document ID	Title
“TRVINFRA-00248 Requirements HMI ICS road operations environment”	TRVINFRA-00248	Requirements for HMI ICS in a road operations environment, version 1.0
“TDOK 2019:316 Requirements Integration NTS”	TDOK 2019:0316	Requirements for NTS Integration, version 1.0
“TRVINFRA-00257 Requirements Vehicle guidance system at traffic control points in road operational environments”	TRVINFRA-00257	Requirements for traffic control systems at road operational environments, version 2.0
“TRVINFRA-00245 Requirements Locations for CCTV (ITV) in road operational environments”	TRVINFRA-00245	Requirements Locations for camera surveillance (ITV) in road operational environments, version 2.0
“TRVINFRA-00254 Requirements Variable speed systems at junctions in road operational environments”	TRVINFRA-00254	Requirements Variable speed systems at junctions in road operational environments, version 2.0
“TRVINFRA-00256 Requirements RSMP”	TRVINFRA-00256	Requirements RSMP, version 4.0

Created by
[Created by]
Case number
[Case number]

Document date
[Document date]

Confidentiality level
[Confidentiality level]

List F. Rail

Designation in TB	Document ID	Title
TRVINFRA-00398 "Requirements Track design Track and station design"	TRVINFRA-00398	Track design Track and station design, version 2.0
TDOK 2016:0407 "Data on railway infrastructure"	TDOK 2016:0407	Data on the railway infrastructure, version 23.0
TDOK 2014:0348 "BVF 521.6 – Requirements for and management of signs and signboards"	TDOK 2014:0348	BVF 521.6 – Requirements for and management of signs and boards, version 1.0
TRVINFRA-00014 "Track Superstructure – Work Affecting Stability"	TRVINFRA-00014	Track Superstructure – Work Affecting Stability, version 5.0
TDOK 2014:0371 "BVF 544.36001 – Requirements for ATC Simulation during Design, Simulation of ATC Plans"	TDOK 2014:0371	BVF 544.36001 - Requirements for ATC simulation during design, Simulation of ATC Plans Requirements, version 2.0
TDOK 2014:0488 "BVF 544.94001 - Technical safety management of signalling, Work on signalling installations".	TDOK 2014:0488	BVF 544.94001 - Technical safety management of signalling, Work on signalling installations, version 4.0
TDOK 2014:0342 "BVF 1544.11000 - Signalling systems. Testing of safety relays (PSR)"	TDOK 2014:0342	BVF 1544.11000 - Signalling systems. Testing of safety relays (PSR), version 1.0
TDOK 2022:0210 "Track components – switching devices"	TDOK 2022:0210	Track components – points, version 1.0
TDOK 2014:0423 "BVH 521.141 "Handbook concerning	TDOK 2014:0423	BVH 521.141 Handbook concerning the Swedish Transport Administration's

Created by
[Created by]
Case number
[Case number]

Document date
[Document date]

Confidentiality level
[Confidentiality level]

Designation in TB	Document ID	Title
“The Swedish Transport Administration’s Track Barriers: Manual for Installation, Care and Maintenance”		Track barriers, Manual for installation, care and maintenance, version 1.0
TDOK 2014:0599 “BVH 524.12 Dimensions for rails and heavy components”	TDOK 2014:0599	BVH 524.12 - Dimensional data for rails and heavy components. Standard profiles and older and obsolete profiles, version 1.0
TDOK 2014:0449 “BVH 540.4 – Boards, signs and labels”	TDOK 2014:0449	BVH 540.4 - Boards, signs and labels, version 1.0
TDOK 2014:0638 “BVH 543.351 System description, Suspension structure calculations”.	TDOK 2014:0638	BVH 543.351 System description, Suspension structure calculations, version 1.0
TDOK 2014:0637 “BVH 543.3501 - Electrical power installations. Design of the Swedish Transport Administration’s high-voltage railway lines”	TDOK 2014:0637	BVH 543.3501 - Electrical power installations. Design of the Swedish Transport Administration’s high-voltage railway lines, version 1.0
TDOK 2014:0397 “BVH 1523.016 - Track switch Heavy-duty control contact eTKK2 mTKK, Design, installation, adjustment and maintenance”.	TDOK 2014:0397	BVH 1523.016 - Track switch heavy-duty control contact eTKK2 mTKK, Design, installation, adjustment and maintenance, version 1.0
TDOK 2014:0416 “BVS 510 Earthing and shielding in the Swedish Transport Administration’s facilities”.	TDOK 2014:0416	BVS 510 – Earthing and shielding in the Swedish Transport Administration’s facilities, version 2.0
TDOK 2014:0586 “BVS 524.20 “Welding of rails and rail components”	TDOK 2014:0586	BVS 524.20 – Welding of rails and rail components.

Created by
[Created by]
Case number
[Case number]

Document date
[Document date]

Confidentiality level
[Confidentiality level]

Designation in TB	Document ID	Title
		Approval of welding procedures, version 2.0
TRVINFRA-00397 "Substations for the Geldsystem. Control unit"	TRVINFRA-00397	Substations for the Geldsystem. Control unit, version 1.0
TRVINFRA-00071 "Low-voltage DC systems for power, telecommunications and signalling installations"	TRVINFRA-00071	Low-voltage DC systems for power, telecommunications and signalling installations, version 4.0
TRVINFRA-00073 "Stations – Stationary emergency power stations"	TRVINFRA-00073	Stations Stationary emergency power stations, version 1.0
TRVINFRA-00075 "High Voltage Marking of cables and cable groups"	TRVINFRA-00075	High Voltage Marking of cables and cable groups, version 1.0
TRVINFRA-00076 "Catenary Catenary System System Description"	TRVINFRA-00076	Overhead contact line Overhead contact line system System description, version 2.0
TRVINFRA-00139 "High Voltage Cable Marking"	TRVINFRA-00139	High voltage Cable marking, version 1.0
TRVINFRA-00144 "Catenary Wiring"	TRVINFRA-00144	Catenary Wiring, version 1.0
TRVINFRA-00085 "Overhead Catenary Reinforcement Cable 15 kV System Description"	TRVINFRA-00085	Catenary Reinforcement Cable 15 kV System Description, version 2.0
TRVINFRA-00153 "Overhead contact line"	TRVINFRA-00153	Overhead contact line Overhead contact line system Design, version 4.0

Created by
[Created by]
Case number
[Case number]

Document date
[Document date]

Confidentiality level
[Confidentiality level]

Designation in TB	Document ID	Title
Overhead contact line system Design		
TRVINFRA-00160 “Qualifications for inspectors and surveyors of railway electrical power installations”	TRVINFRA-00160	Qualifications for inspectors and surveyors of railway electrical power installations, version 2.0
TRVINFRA-00086 “Overhead contact line, 15 kV feeder line, system description”	TRVINFRA-00086	Overhead contact line 15 kV feeder line System description, version 1.0
TRVINFRA-00087 “ Overhead contact line Return line 15 kV System description”	TRVINFRA-00087	Catenary Return Line 15 kV System Description, version 1.0
TRVINFRA-00089 “Overhead contact line: Position of poles in relation to tracks – Installation description”	TRVINFRA-00089	Overhead contact line: Position of poles in relation to tracks – Installation description, version 1.0
TRVINFRA-00090 “Overhead contact line: Overhead contact line pole, permissible torques – Installation description”	TRVINFRA-00090	Overhead contact line Overhead contact line pole, permissible torques Installation description”, version 1.0
TRVINFRA-00091 “Overhead contact line Designations Poles Installation description”	TRVINFRA-00091	Overhead contact line Designations Poles Installation description, version 2.0
TDOK 2014:0896 “BVS 543.36336 Technical regulations, contact wire for overhead contact lines”.	TDOK 2014:0896	BVS 543.36336 Technical regulations, contact wire, version 1.0

Created by
[Created by]
Case number
[Case number]

Document date
[Document date]

Confidentiality level
[Confidentiality level]

Designation in TB	Document ID	Title
TRVINFRA-00137 “Overhead contact line, overhead contact line bridge”	TRVINFRA-00137	Catenary Catenary bridge, version 1.0
TRVINFRA-00121 “Overhead contact line: Cantilevers and pipe sets”	TRVINFRA-00121	Overhead contact line brackets and pipe sets, version 1.0
TRVINFRA-00122 “Overhead Contact Line Tensioning System Description”	TRVINFRA-00122	Overhead contact line tensioning system description, version 2.0
TRVINFRA-00124 “Overhead Catenary Installation on Poles and Bridges”	TRVINFRA-00124	Catenary Installation on Poles and Girders, version 2.0
TDOK 2014:0912 “BVS 543.37621 - Protective sections”.	TDOK 2014:0912	BVS 543.37621 – Protection sections, version 1.0
TRVINFRA-00125 “Overhead contact line Control device for disconnectors	TRVINFRA-00125	Overhead contact line Control device for disconnectors, version 1.0
TRVINFRA-00126 “High Voltage Signs and safety gates at level crossings with electrified railways”	TRVINFRA-00126	High Voltage Signs and safety gates at level crossings with electrified railways, version 1.0
TDOK 2014:0590 “BVS 544.22201 – Computer-based signal boxes – management of systems and installations”	TDOK 2014:0590	BVS 544.22201 – Computer-based signal boxes – management of systems and installations, version 6.0
TDOK 2014:0487 “BVS 544.93301 – Signalling technology	TDOK 2014:0487	BVS 544.93301 – Signalling technical functional requirements,

Created by
[Created by]
Case number
[Case number]

Document date
[Document date]

Confidentiality level
[Confidentiality level]

Designation in TB	Document ID	Title
Functional requirements, Signalling functional requirements for the procurement of signal boxes, models 85 and 95”.		Signalling functional requirements for the procurement of signal boxes, models 85 and 95, version 3.0
TRVINFRA-00301 “General design”	TRVINFRA-00301	General design, version 14.0
TRVINFRA-00302 “Signalling”	TRVINFRA-00302	Signalling, version 12.0
TRVINFRA-00303 "Reservation of track sections"	TRVINFRA-00303	Track Section Reservation, Version 5.0
TRVINFRA-00307 "Construction"	TRVINFRA-00307	Construction, version 9.0
TRVINFRA-00308 "Commissioning and inspection"	TRVINFRA-00308	Commissioning and inspection, version 6.0
TDOK 2014:0528 “BVS 544.94008 – Authorisation, Signal Safety Inspector and Trainer for Signal Safety Inspectors”	TDOK 2014:0528	BVS 544.94008 - Qualifications, Signal Safety Inspector and Signal Safety Inspector Trainer, version 3.0
TDOK 2014:0498 “BVS 544.94009 - Qualification, Commissioning Inspector for Signalling Technology”	TDOK 2014:0498	BVS 544.94009 - Qualification, Commissioning Inspector for Signalling Technology, version 4.0
BVS 728 “Traffic information for passengers at and near the operating site – standard for traffic information equipment”		BVS 728 “Traffic information for passengers at and near the operating site – standard for traffic information equipment”

Created by
[Created by]
Case number
[Case number]

Document date
[Document date]

Confidentiality level
[Confidentiality level]

Designation in TB	Document ID	Title
TRVINFRA-00063 “Low-voltage Technical Building System Description”	TRVINFRA-00063	Low Voltage Technical Building System Description, version 10.0
TRVINFRA-00051 “General Train and Locomotive Heating System System Description”	TRVINFRA-00051	General Train and Locomotive Heating System System Description, version 2.0
“BVS 1585.005 Standard sections for the track”	TDOK 2015:0198	BVS 1585.005 - Standard sections for the track, version 2.0
“Points Design Manual”	TDOK 2013:0478	Track Switch Design Manual, version 4.0
TRVINFRA-00146 “High Voltage Designations for Disconnectors and Other Objects”	TRVINFRA-00146	High Voltage Designations for Disconnectors and Other Objects, version 2.0
TRVINFRA-00141 “Low Voltage Track Switch Heating Control with IMSE WebMasterPro System Description”	TRVINFRA-00141	Low Voltage Track Switch Heating Control with IMSE WebMasterPro Installation Description, version 3.0
TRVINFRA-00144 “Overhead Catenary Wire routing	TRVINFRA-00144	Overhead contact line Wiring, version 1.0
Data on the facility – Coding of geographical objects – Railway	TDOK 2019:0215	TDOK 2019:0215 Facility data the facility – Coding of geographical objects – Railway, version 9.0
TDOK 2013:0689 “DETECTORS – Requirements for the selection of detector locations”.	TDOK 2013:0689	DETECTORS – Requirements for the selection of detector locations, version 3.0
TDOK 2014:0065 “Physical security at the Swedish Transport Administration”.	TDOK 2014:0065	Physical security at the Swedish Transport Administration, version 4.0

Created by
[Created by]
Case number
[Case number]

Document date
[Document date]

Confidentiality level
[Confidentiality level]

Designation in TB	Document ID	Title
TDOK 2018:0640 "Cable ducts".	TDOK 2018:0640	Cable ducting, version 1.0
TRVINFRA-00044 "Electrical power distribution systems: Connection of remote control units to the Geld-ICS environment via IEC 870-5-104", version 1.0	TRVINFRA- 00044	"Electrical control system: Connection of remote control units to the Geld-ICS environment via IEC 870-5-104", version 1.0
TRVINFRA-00127 "General Lightning protection measures for power supply to railway installations"	TRVINFRA- 00127	General Lightning Protection Measures for Power Supply to Railway Installations, Version 2.0
TRVINFRA-00052 "Electric traction control system Signal exchange between power supply facilities and the electric traction control system System description"	TRVINFRA- 00052	Electric traction power supply system Signal exchange between power supply facilities and the electric traction power supply system System description, version 1.0
TRVINFRA-00151 "Lighting in the railway environment"	TRVINFRA- 00151	Lighting in railway environments, version 1.0
"BVS 1524.210 "Butt welding. Thermite and mould welding"	TDOK 2014:0548	BVS 1524.210 – Butt welding, thermite and mould welding, version 1.0
TRVINFRA-00088 ” Catenary 15 kV System Description”	TRVINFRA- 00088	Overhead contact line, 15 kV system description, version 1.0
"Routing of cables and cable crossings within or adjacent to railway lines"	TDOK 2014:0945	Laying of cables and cable crossings

Created by
[Created by]
Case number
[Case number]

Document date
[Document date]

Confidentiality level
[Confidentiality level]

Designation in TB	Document ID	Title
		within or adjacent to railway lines, version 1.0
“Safety inspection – authorisation management”	TDOK 2013:0195	“Safety inspection – access control”, version 5.0
TRVINFRA-00140 “General Application of high-voltage regulations in the design of the Swedish Transport Administration’s railway facilities”	TRVINFRA-00140	General Application of high-voltage regulations in the design of the Swedish Transport Administration’s railway facilities, version 1.0
BVS 543.36323 TECHNICAL REGULATIONS, Electrical power installations, Distribution transformers for auxiliary power lines	TDOK 2014:0880	TDOK 2914:0880 “BVS 543.36323”, TECHNICAL REGULATIONS, Electrical power installations, Distribution transformers for auxiliary power lines, version 1.0
TRVINFRA-00077 “Contact wire S 4.9/5.9 System description”	TRVINFRA-00077	Contact wire S 4.9/5.9 System description”, version 3.0
TRVINFRA-00078 “Overhead contact line ST 7.1/7.1 System description”	TRVINFRA-00078	Overhead contact line ST 7.1/7.1 System description, version 3.0
TRVINFRA-00079 “Overhead contact line ST 9.8/9.8 System description”	TRVINFRA-00079	ST 9.8/9.8 catenary System description, version 3.0
TRVINFRA-00080 “Overhead contact line ST 9.8/11.8 System description”	TRVINFRA-00080	ST 9.8/11.8 catenary System description, version 3.0

Created by
[Created by]
Case number
[Case number]

Document date
[Document date]

Confidentiality level
[Confidentiality level]

Designation in TB	Document ID	Title
TRVINFRA-00081 “Catenary SYT 7.0/9.8 System description”	TRVINFRA- 00081	SYT overhead contact line 7.0/9.8 System description, version 3.0
TRVINFRA-00082 “SYT contact wire 9.8/9.8 System description”	TRVINFRA- 00082	SYT overhead contact line 9.8/9.8 System description, version 3.0
TRVINFRA-00083 “ST 15/15 overhead contact line system description”	TRVINFRA- 00083	ST 15/15 overhead contact line System description, version 3.0
TRVINFRA-00084 “SYT 15/15 Catenary System Description”	TRVINFRA- 00084	Catenary SYT 15/15 System Description, version 5.0
TRVINFRA-00092 “SYT contact wire 21/27 System description	TRVINFRA- 00092	SYT overhead contact line 21/27 System description, version 1.0
TRVINFRA-00136 “ Catenary: Foundations and guy anchors”	TRVINFRA- 00136	Catenary Foundation and Stay Anchoring, version 1.0
TDOK 2014:0716 “BVS 1518.4004” Electrical power installations. Aluminium cable for protective and operational earthing”	TDOK 2014:0716	TDOK 2014:0716 “BVS 1518.4004” Electrical power installations. Aluminium cable for protective and operational earthing, version 1.0
TRVINFRA-00049 “Low-voltage 1 kV distribution network System description”.	TRVINFRA- 00049	Low-voltage 1 kV distribution network System description” ver 2.0.
TRVINFRA-00059 “ Low Voltage Uninterruptible Power Supply – UPS System Description”.	TRVINFRA- 00059	Low-voltage Uninterruptible Power Supply – UPS System Description, version 1.0

Created by
[Created by]
Case number
[Case number]

Document date
[Document date]

Confidentiality level
[Confidentiality level]

Designation in TB	Document ID	Title
TRVINFRA-00053 “Stations: Design and Construction – Engineering”.	TRVINFRA-00053	Stations: Design and Construction, version 1.0
TRVINFRA-00133 “Electrical Power Distribution Systems: Interlocking and Operating Conditions”.	TRVINFRA-00133	Electrical Control System Interlocking and Operating Conditions, version 1.0
TRVINFRA-00134 “Stations: Metal-enclosed switchgear”.	TRVINFRA-00134	Metal-enclosed switchgear stations, version 1.0
TRVINFRA-00057 “Relay protection stations”.	TRVINFRA-00057	Stations: Relay protection, version 2.0
TRVINFRA-00174 “Installation of GSM-R equipment for fixed telephony in power supply facilities”.	TRVINFRA-00174	Installation of GSM-R equipment for fixed telephony in power supply facilities , version 1.0
TRVINFRA-00070 “Station Designations”.	TRVINFRA-00070	Station Designations, version 2.0
TRVINFRA-00138 “General EMC requirements for electrical equipment in the Swedish Transport Administration’s facilities”.	TRVINFRA-00138	General EMC requirements for electrical equipment in the Swedish Transport Administration’s facilities, version 2.0
TDOK 2014:0675 “BVS 1543.14242 - Electrical power installations. Energy metering in electrical power installations”.	TDOK 2014:0675	BVS 1543.14242 - Electrical power installations. Energy metering in electrical power installations, version 1.0
TRVINFRA-00061 “Stations Analogue interfaces between rotating converters and	TRVINFRA-00061	Stations Analogue interfaces between rotating converters and fixed stations

Created by
[Created by]
Case number
[Case number]

Document date
[Document date]

Confidentiality level
[Confidentiality level]

Designation in TB	Document ID	Title
fixed stations System description”.		System description, version 1.0
TDOK 2013:0433 “Procedures before and after transport of mobile converters”.	TDOK 2013:0433	Procedures before and after transport of mobile converters, version 3.0
TDOK 2013:0407 “Transport of mobile inverters”.	TDOK 2013:0407	Transport of mobile inverters, version 3.0
TDOK 2013:0670 “BVS 1543.17000 – Electrical power installations, Converters for track power supply”.	TDOK 2013:0670	BVS 1543.17000 – Electrical power installations, Converters for track power supply, version 1.0
TRVINFRA-00055 “Emergency disconnection and total shutdown”.	TRVINFRA- 00055	Emergency disconnection and total shutdown, version 2.0
TDOK 2013:0640 “Electrical power installations. Documentation requirements for power supply installations”.	TDOK 2013:0640	“Electrical power installations. Documentation requirements for power supply installations”, version 6.0.
TRVINFRA-00135 “Stations. Station control systems. Major installations”.	TRVINFRA- 00135	Stations Station control systems Larger facilities, version 4.0
TRVINFRA-00389 “ Electrical Power Plant. Computerised HMI in Electrical Power Plants”	TRVINFRA- 00389	Electrical power plant. Computerised HMI in electrical power plants. Version 1.0
TRVINFRA-00370 “Electrical power plant, Application of SS EN 61850”	TRVINFRA- 00370	Electrical power plant, Application of SS EN 61850, version 1.0

Created by
[Created by]
Case number
[Case number]

Document date
[Document date]

Confidentiality level
[Confidentiality level]

Designation in TB	Document ID	Title
TRVINFRA-00168 “Substations – Substation control systems for simpler power supply installations”	TRVINFRA-00168	Stations Station control system for simpler power supply installations, version 5.0
TRVINFRA-00143 “Converter Station Site and Building Requirements for Static Converters – Facility Description”.	TRVINFRA-00143	Converter station Site and building requirements for static converters Facility description, version 2.0
TRVINFRA-00056 “Stations Local Power Systems System Description”.	TRVINFRA-00056	Stations Local Power Systems System Description, version 1.0
TRVINFRA-00128 “Converter station and transformer station, 3-phase 50 Hz and 1-phase 16 2/3 Hz outdoor switchgear with a design voltage between 52 kV and 145 kV”.	TRVINFRA-00128	Converter station and transformer station, 3-phase 50 Hz and 1-phase 16 2/3 Hz outdoor switchgear with a design voltage between 52 kV and 145 kV, version 1.0
TRVINFRA-00134 “Metal-enclosed switchgear”.	TRVINFRA-00134	Metal-enclosed switchgear, version 1.0
TDOK 2013:0680 “BVS 543.14512 - Feeder transformer for auxiliary power lines in the Swedish Transport Administration’s power supply facilities, Technical regulations”.	TDOK 2013:0680	BVS 543.14512 - Feeder transformer for auxiliary power lines in the Swedish Transport Administration’s power supply facilities, Technical regulations, version 1.0
TDOK 2021:0437 Design manual for low-voltage installations	TDOK 2021:0437	TDOK 2021:0437 Design manual for low-voltage installations

Created by
[Created by]
Case number
[Case number]

Document date
[Document date]

Confidentiality level
[Confidentiality level]

Designation in TB	Document ID	Title
and railway engineering structures.		and railway engineering structures. Version 2.0
UHte 16-083 “Summary of signal exchange within electrical power installations and with overhead contact line systems”.	UHte 16-083	UHte 16-083 “Summary of signal exchange within electrical power installations and with overhead contact line systems”, version 1.5. The UHte document is requested from the client.
TRV 2021/99388 “Interlocking function for motor-operated railway circuit breakers”.	TRV 2021/99388	TRV 2021/99388 “Interlocking function for motor-operated railway isolator controls”.
TDOK 2014:0507 “BVS1543.11601 Power supply installations – Autotransformer system – system description”.	TDOK 2014:0507	BVS1543.11601 Power supply installations Autotransformer systems – system description, ver 2.0
TRVINFRA-00304 “Level crossings”.	TRVINFRA- 00304	Level crossings, version 15.0
TRVINFRA-00399 “Requirements Physical barrier railway”	TRVINFRA- 00399	Requirements for physical barriers on railways, version 1.0
TRVINFRA-00367 “Design of CCTV surveillance in railway facilities”	TRVINFRA- 00367	Design of CCTV surveillance in railway facilities, version 3.0
TRVINFRA-00358 “Requirements design and characteristics”	TRVINFRA- 00358	Requirements, design and characteristics, version 1.0
TRVINFRA-00332 “Technical requirements for	TRVINFRA- 00332	Technical requirements for surveillance cameras in

Created by
[Created by]
Case number
[Case number]

Document date
[Document date]

Confidentiality level
[Confidentiality level]

Designation in TB	Document ID	Title
surveillance cameras in the railway facility”		the railway facility, version 2.0
TRVINFRA-00179 “Low-voltage power cable installation and signalling system for railways”	TRVINFRA-00179	Low-voltage power cable installation and marking system for railways, version 1.0
TRVINFRA-00178 “High-voltage cable systems”	TRVINFRA-00178	High-voltage cable systems, version 1.0
TRVINFRA-00173 “Electrical Power Systems Electrical Safety Earthing of contact lines during rescue operations in tunnels”	TRVINFRA-00173	Electrical Power Systems Electrical Safety Earthing of contact lines during rescue operations in tunnels; version 1.0
TRVINFRA-00169 “High Voltage Auxiliary Power System 50Hz”	TRVINFRA-00169	High Voltage Auxiliary Power System 50Hz, version 1.0
TRVINFRA-00166 “Low Voltage Design of Local Control Rooms at Manned Stations/Operating Sites”	TRVINFRA-00166	Low Voltage Design of local control rooms at manned stations/operating sites, version 1.0”
TRVINFRA-00162 “Overhead contact line: Update of wiring diagrams and group diagrams for the Swedish Transport Administration’s overhead contact line and auxiliary power line installations”	TRVINFRA-00162	Catenary Update of connection diagrams and group diagrams for the Swedish Transport Administration’s catenary and auxiliary power line installations, version 2.0
TRVINFRA-00132 “Low Voltage Electrical Equipment in Railway Tunnels – System Descriptions”	TRVINFRA-00132	Low-voltage electrical equipment in railway tunnels – System descriptions, version 2.0

Created by
[Created by]
Case number
[Case number]

Document date
[Document date]

Confidentiality level
[Confidentiality level]

Designation in TB	Document ID	Title
TRVINFRA-00123 “Overhead contact line Tension and adjustment tables for fixed tensioned wires and cantilevers. Al212, Cu130, Cu 35, FeAl 99, FeAl 66 cable. Cantilever adjustment”	TRVINFRA- 00123	Catenary Tension and adjustment tables for fixed tensioned wires and cantilevers. Al212, Cu130, Cu 35, FeAl 99, FeAl 66 wire. Cantilever adjustment. Version 2.0
TRVINFRA-00114 “Overhead contact line and auxiliary power line connection points”	TRVINFRA- 00114	Contact wire and auxiliary power line connection points, version 1.0
TRVINFRA-00074 “General Design of Steel Structures and Overhead Cables”	TRVINFRA- 00074	General Design of steel structures and overhead lines, version 1.0
TRVINFRA-00060 “Converter Station Relay Protection and Monitoring Functions in Rotating Converters – System Description”	TRVINFRA- 00060	Converter Station Relay Protection and Monitoring Functions in Rotating Converters System Description, version 1.0
TRVINFRA-00047 “Catenary Protection Devices – Safety Nets”	TRVINFRA- 00047	Overhead contact line Protective devices – Safety nets, version 1.0
TRVINFRA-00046 “Overhead Catenary Anchoring, Braces, Supports, Struts”	TRVINFRA- 00046	Overhead contact line Anchoring, stays, supports, struts, version 1.0
TRVINFRA-00045 “General Insulating fluids for transformers and other high- voltage products”	TRVINFRA- 00045	General Insulating fluids for transformers and other high-voltage products, version 1.0

Created by
[Created by]
Case number
[Case number]

Document date
[Document date]

Confidentiality level
[Confidentiality level]

Designation in TB	Document ID	Title
TRVINFRA-00043 “Overhead contact line wiring diagram”	TRVINFRA-00043	Catenary wiring diagram, version 2.0
TRVINFRA-00040 “Overhead contact line: Intersection with high-voltage power lines over and under railways or tramways”	TRVINFRA-00040	Overhead contact line crossing with high-voltage power lines above and below railways or tramways, version 1.0
TRVINFRA-00402 “Design of traffic information equipment at railway stations”	TRVINFRA-00402	TRVINFRA-00402 Design of traffic information equipment at railway stations, version 2.0
TRVINFRA-00395 “Railway Complex Facility – Tunnel”	TRVINFRA-00395	TRVINFRA-00395 Railway Complex facility – Tunnel, version 1.0
TRVINFRA-00397 “Substation for the Geldsystem Control Unit”.	TRVINFRA-00397	TRVINFRA-00397 Substation for the Geldsystem Control Unit, Version 1.0
TRVINFRA-00394 “Railway Design Specification: Building Automation”	TRVINFRA-00394	TRVINFRA-00394 Railway Design Guidelines for Building Automation, Version 1.0
TRVINFRA-00393 “Railway General Requirements”	TRVINFRA-00393	TRVINFRA-00393 Rail General Requirements, version 1.0
TRVINFRA-00018 “Track Components”	TRVINFRA-00018	TRVINFRA-00018 Track components, version 5.0
TRVINFRA-00017 “Track switch”	TRVINFRA-00017	TRVINFRA-00017 Track switch, version 5.0

Created by
[Created by]
Case number
[Case number]

Document date
[Document date]

Confidentiality level
[Confidentiality level]

Designation in TB	Document ID	Title
TRVINFRA-00012 “Requirements Track superstructure track system”	TRVINFRA-00012	Requirements for Track Superstructure track system”, version 4.0,
TRVINFRA-00018 “Requirements Track Superstructure Track Components”	TRVINFRA-00018	Requirements Track superstructure track components, version 5.0
TRVINFRA-00013 “Requirements Track superstructure track alignment”	TRVINFRA-00013	Requirements for track alignment, version 2.0
TRVINFRA-00016 “Requirements Track superstructure welding, machining and lubrication	TRVINFRA-00016	Requirements for track superstructure: welding, machining and lubrication, version 2.0
TRVINFRA-00271 “Requirements Track superstructure technical Safety control”	TRVINFRA-00271	Requirements for Railway Superstructure – Technical Safety Control, version 2.0

Document properties, Case number [Case number], Created by Paananen Tommy, PProp2, Document date 29/09/2025, Document type FORM, Confidentiality level [Confidentiality level].

The text fields above are intended for digital reading only and must not be removed. They contain information from the header and the document’s properties are made available in accordance with the Act (2018:1937) on Accessibility to Digital Public Services.

Created by
[Created by]
Case number
[Case number]

Document date
[Document date]

Confidentiality level
[Confidentiality level]

List A. Common requirements, X. Documentation and common requirements documents (D and F).

Designation in TB	Document ID	Title
AMA Facility		AMA Facility 23
AMA Electrical		AMA Electrical 22
Construction Documents 90 Part 7		Construction Documents 90 Part 7 Report on Civil Engineering Works, Edition 2
“Requirements for Geodetic Surveying and Geographical Positioning”	TDOK 2014:0571	Geodetic Surveying and Geographical Positioning – Roads and Railways, version 5.0
“Requirements TK Drainage”	TDOK 2014:0045	Requirements Swedish Transport Administration’s technical requirements for drainage – TK Drainage, version 2.0
“Guidance TR Drainage”	TDOK 2014:0046	Guidance Swedish Transport Administration’s technical requirements for drainage – TK Drainage, version 3.0
“MB 310”	TDOK 2014:0051	Drainage engineering design and layout – MB 310, version 3.0
“TRVINFRA-00231”	TRVINFRA-00231	Requirements for Drainage, Design and layout, version 3.0
“Publication: Surface and Groundwater Protection”	Publication 2020:171	Surface and Groundwater Protection – Methodology for Risk Management and Risk Analysis, and Principles for selecting measures
SIS-TS 21144:2016		Technical Specification SIS-TS 21144:2013 Construction surveying – Specifications for the production and verification of digital terrain models
TDOK 2012:35 “Digital project management”	TDOK 2012:35	Digital project management, version 9.0

Created by
[Created by]
Case number
[Case number]

Document date
[Document date]

Confidentiality level
[Confidentiality level]

Designation in TB	Document ID	Title
TRVINFRA-00145 "LED luminaires – Requirements"	TRVINFRA-00145	Requirements for LED luminaires, version 2.0
NMF01:2021	NMF01:2021	Technical specification. LED luminaires – requirements. (NMF = Nordic Forum for Improved Road Equipment)
"Requirements for bridges and bridge-like structures, General requirements"	TRVINFRA-00226	Requirements for bridges and bridge-like structures, General requirements, version 5.0
"Requirements for bridges and bridge-like structures, Construction"	TRVINFRA-00227	Requirements for bridges and bridge-like structures, Construction, Version 5.0
"Requirements for bridges and bridge-like structures, Bridge Maintenance"	TRVINFRA-00228	Requirements for Bridges and Bridge-like structures, Bridge maintenance, version 6.0
"Requirements for geotechnical structures, administrative rules"	TRVINFRA-00229	Requirements for Geotechnical Engineering, Administrative Rules, version 2.0
"Requirements for Geotechnical Engineering, design and design"	TRVINFRA-00230	Requirements for Geotechnical Engineering, dimensioning and design, version 2.0
TDOK 2015:0223 "Electrical safety regulations for work on or near railway-related high-voltage and train heating installations"	TDOK 2015:0223	Electrical safety regulations for work on or near railway-related high-voltage and train heating installations, version 7.0
"TRV AMA Installation"	TDOK 2023:0125	The Swedish Transport Administration's amendments and additions to AMA Installation 23, version 2.0
"TRV AMA Electrical"	TDOK 2022:0324	The Swedish Transport Administration's amendments and additions to AMA EI 22, version 5.0
"SGF Report 2:2013"		Field Manual: Investigations of Contaminated Sites (SGF Report 2:2013)
"Object-Oriented Information Model"	TDOK 2015:0181	Object-Oriented Information Model version 4.0
"Requirements – Cable Systems. Cable Removal"	TRVINFRA-00348	Requirements – Cable systems. Cable removal, version 1.0

Created by
[Created by]
Case number
[Case number]

Document date
[Document date]

Confidentiality level
[Confidentiality level]

Designation in TB	Document ID	Title
“EBR Handbook KJ 41:21 Cable Laying up to 145 kV”	EBR KJ 41:21	“EBR Handbook KJ 41:21 Cable Laying up to 145 kV” published in 2021 (Svensk Energi – Swedenergy AB)
TDOK 2018:0198 “Managing managing electricity accounts”	TDOK 2018:0198	Procedure description – Managing electricity subscriptions, version 3.0
“TRVK Apv”	TDOK 2012:86	TRK Apv, the Swedish Transport Administration’s technical requirements for road works roads, version 5.0

List D. Road **Lisan** has not been finalised

Designation in TB	Document ID	Title
“Design and construction of private roads”.	Publication 2020:089	Design and construction of private roads. Version 2.0
“Swedish Forest Agency, Guidelines for the design and construction of forest roads Class III and IV”		Swedish Forest Agency, Guidelines for the design and construction of forest roads Class III and IV
“Utility works within the state road network”	Publication 2022:129	Utility works within the state road area, version 1.0
TDOK 2013:0461 “Control survey of longitudinal road markings by car”	TDOK 2013:0461	Inspection measurement of longitudinal road markings by car, version 2.0
TDOK 2013:0580 “Electrical power installations. Control systems for lighting installations for roads”	TDOK 2013:0580	Electrical power installations. Control systems for road lighting installations, version 1.0
TDOK 2013:0462 “Hand-held inspection of longitudinal and transverse road markings”	TDOK 2013:0462	Hand-held inspection measurement of longitudinal and transverse markings, version 1.0
TDOK 2013:0669 “Inventory of frost-related damage to existing roads”	TDOK 2013:0669	Inventory of frost-related damage to existing roads, version 2.0

Created by
[Created by]
Case number
[Case number]

Document date
[Document date]

Confidentiality level
[Confidentiality level]

Designation in TB	Document ID	Title
“TDOK 2014:0005”	TDOK 2014:0005	Road network measurement Object, version 1.0
“TDOK 2014:0151”	TDOK 2014:0151	Requirements – Sampling of unbound materials, version 1.0
TDOK 2014:0134 “Determination of friction on paved surfaces”	TDOK 2014:0134	Determination of friction on paved surfaces, version 3.0
“TDOK 2014:0136”	TDOK 2014:0136	Determination of unevenness and crossfall using a straightedge, version 1.0
TDOK 2019:0463	TDOK 2019:0463	Evaluation of the bearing capacity of road structures using a drop weight apparatus, version 1.0
“TRVMB 350”	Publication 2012:053	TRVMB 350 Guardrails -Classification, performance requirements for collision testing and test methods
“Requirements – VGU”	TRVINFRA-00396	Requirements – VGU, Road and Street Design, version 1.0
“VGU – Basic Values”	Publication 2024:148	Requirements Core Values: Road and Street Design Requirements, version 1.0
TRVINFRA-00224 Road Superstructure, Dimensioning and Design	TRVINFRA-00224	Road Superstructure, Dimensioning and Design version 4.0
“VVMB 908”	Publication 1994:41	VVMB 908 Statistical acceptance control
“System number and Component designations – Requirements”	TDOK 2012:1171	System numbers and component designations – Requirements, version 9.0
TRVINFRA-00234 Marking in road operational environments	TRVINFRA-00234	Signage in road operational environments – Requirements, version 4.0
Facility data – Data and documentation for management systems – Roads	TDOK 2019:0210	TDOK 2019:0210 Data on the facility – Data and documentation for management systems – Roads, Requirements version 13.0

Created by
[Created by]
Case number
[Case number]

Document date
[Document date]

Confidentiality level
[Confidentiality level]

Designation in TB	Document ID	Title
Lighting columns within the road area	TRVINFRA-00159	Lighting columns within the road area, version 1.0
Separation of bundled cables for road lighting	TDOK 2020:0259	Separation of bundled networks for road lighting, version 5.0
Control and monitoring Traffic control point	TRVINFRA-00258	Control and monitoring Traffic control centre, version 2.0
TRVINFRA-00264	TRVINFRA-00264	Control and monitoring Requirements for pump station control cabinets, version 1.0
“Bituminous layers, TDOK 2013:0529”	TDOK 2013:0529	Bituminous layers, version 4.0
“TDOK 2013:0530 Unbound layers for road structures”	TDOK 2013:0530	Unbound layers for road structures, version 3.0

List F. Railways (Items marked in yellow are not included in Chapter F).

Designation in FB	Document ID	Title
TRVINFRA-00398 “Requirements Track design Track and station design”	TRVINFRA-00398	Track design Track and station design, version 2.0
TRVINFRA-00014 “Track Superstructure Work Affecting Stability”	TRVINFRA-00014	Track Superstructure: Work Affecting Stability, version 5.0
TDOK 2014:0371 “BVF 544.36001 – Requirements for ATC simulation during design, Simulation of ATC Plans”	TDOK 2014:0371	BVF 544.36001 - Requirements for ATC simulation during planning, Simulation of ATC Plans Requirements, version 2.0
TDOK 2014:0488 “BVF 544.94001 – Technical safety control of signalling, Work on signalling systems”	TDOK 2014:0488	BVF 544.94001 - Technical safety control of signalling, Work on signalling systems, version 4.0
TDOK 2014:0342 “BVF 1544.11000 - Signalling systems. Testing of safety relays (PSR)”	TDOK 2014:0342	BVF 1544.11000 - Signalling systems. Testing of safety relays (PSR), version 1.0
TDOK 2022:0210 “Track components – switching device”	TDOK 2022:0210	Track components switch, version 1.0

Created by
[Created by]
Case number
[Case number]

Document date
[Document date]

Confidentiality level
[Confidentiality level]

Designation in FB	Document ID	Title
TDOK 2014:0423 "BVH 521.141 "Handbook on the Swedish Transport Administration's track barriers, Manual for installation, care and maintenance"	TDOK 2014:0423	BVH 521.141 Handbook on the Swedish Transport Administration's track barriers, Manual for installation, care and maintenance, version 1.0
TDOK 2014:0599 "BVH 524.12 Dimensional data for rails and heavy components"	TDOK 2014:0599	BVH 524.12 - Dimensions for rails and heavy components. Standard profiles and older and obsolete profiles, version 1.0
TDOK 2014:0449 "BVH 540.4 – Boards, signs and labels"	TDOK 2014:0449	BVH 540.4 – Signs, plaques and labels, version 1.0
TDOK 2014:0638 "BVH 543.351 System description, Suspension structure calculations"	TDOK 2014:0638	BVH 543.351 System description, Suspension structure calculations, version 1.0
TDOK 2014:0637 "BVH 543.3501 - Electrical power installations. Design of the Swedish Transport Administration's high-voltage power lines for railways"	TDOK 2014:0637	BVH 543.3501 - Electrical power installations. Design of the Swedish Transport Administration's high-voltage power lines for railways, version 1.0
TDOK 2014:0397 "BVH 1523.016 - Track switch heavy-duty control contact eTKK2 mTKK, Design, installation, adjustment and maintenance"	TDOK 2014:0397	BVH 1523.016 - Point switch heavy-duty control contact eTKK2 mTKK, Design, installation, adjustment and maintenance, version 1.0
TDOK 2014:0416 "BVS 510 Earthing and shielding in the Swedish Transport Administration's facilities"	TDOK 2014:0416	BVS 510 – Earthing and shielding in the Swedish Transport Administration's facilities, version 2.0
TDOK 2014:0586 "BVS 524.20 "Welding of rails and rail components"	TDOK 2014:0586	BVS 524.20 – Welding of rails and rail components. Approval of welding procedures, version 2.0
TRVINFRA-00397 "Substations for the Geldsystem. Control unit"	TRVINFRA-00397	Substations for Geldsystemet. Control unit, version 1.0
TRVINFRA-00071 "Low-voltage Direct current systems for power, telecommunications and signalling installations"	TRVINFRA-00071	Low-voltage DC systems for power, telecommunications and signalling installations, version 4.0
TRVINFRA-00073 "Stations: Stationary emergency power stations"	TRVINFRA-00073	Stations Stationary emergency power stations, version 1.0

Created by
[Created by]
Case number
[Case number]

Document date
[Document date]

Confidentiality level
[Confidentiality level]

Designation in FB	Document ID	Title
TRVINFRA-00075 "High Voltage Marking of cables and cable groups"	TRVINFRA-00075	High Voltage Marking of cables and cable assemblies, version 1.0
TRVINFRA-00076 "Catenary Catenary system System description"	TRVINFRA-00076	Overhead contact line Overhead contact line system System description, version 2.0
TRVINFRA-00139 "High voltage Cable marking"	TRVINFRA-00139	High voltage Cable marking, version 1.0
TRVINFRA-00144 "Catenary Wiring"	TRVINFRA-00144	Catenary Wiring, version 1.0
TRVINFRA-00085 "Overhead contact line 15 kV Reinforcement Cable System Description"	TRVINFRA-00085	Catenary 15 kV Reinforcement Line System Description, version 2.0
TRVINFRA-00153 "Overhead contact line Overhead contact line system Design"	TRVINFRA-00153	Overhead contact line Overhead contact line system Design, version 4.0
TRVINFRA-00160 "Qualifications for Inspectors and Surveyors Railway Electrical Power Supply Systems"	TRVINFRA-00160	Qualifications for inspectors and surveyors railway electrical power installations, version 2.0
TRVINFRA-00086 "Overhead contact line 15 kV feeder line System description"	TRVINFRA-00086	Overhead contact line 15 kV feeder line System description, version 1.0
TRVINFRA-00087 "Contact wire Return line 15 kV System Description"	TRVINFRA-00087	Overhead contact line Return circuit 15 kV System description, version 1.0
TRVINFRA-00089 "Overhead contact line: Location of poles in relation to track Installation Description"	TRVINFRA-00089	Overhead contact line: Position of poles in relation to the track – System description, version 1.0
TRVINFRA-00090 "Overhead contact line Overhead contact line pole, permissible torques Facility description"	TRVINFRA-00090	Overhead contact line Overhead contact line pole, permissible torques Installation description", version 1.0
TRVINFRA-00091 "Overhead contact line Designations Poles System description"	TRVINFRA-00091	Overhead contact line Designations Poles Installation description, version 2.0

Created by
[Created by]
Case number
[Case number]

Document date
[Document date]

Confidentiality level
[Confidentiality level]

Designation in FB	Document ID	Title
TDOK 2014:0896 "BVS 543.36336 Technical regulations, suspension wire for catenary".	TDOK 2014:0896	BVS 543.36336 Technical regulations, contact wire, version 1.0
TRVINFRA-00137 "Overhead contact line, overhead contact line bridge"	TRVINFRA-00137	Overhead contact line, overhead contact line bridge, version 1.0
TRVINFRA-00121 "Overhead contact line: Brackets and pipe sets"	TRVINFRA-00121	Catenary Cantilevers and pipe sets, version 1.0
TRVINFRA-00122 "Overhead Contact Line Tensioning System Description"	TRVINFRA-00122	Overhead contact line tensioning system description, version 2.0
TRVINFRA-00124 "Overhead Catenary Installation on Poles and Girders"	TRVINFRA-00124	Overhead Catenary Installation on Poles and Girders, version 2.0
TDOK 2014:0912 "BVS 543.37621 - Protective sections".	TDOK 2014:0912	BVS 543.37621 - Protection sections, version 1.0
TRVINFRA-00125 "Contact wire Control device for disconnectors"	TRVINFRA-00125	Overhead contact line Control device for disconnectors, version 1.0
TRVINFRA-00126 "High voltage Signs and safety gates at level crossings with electrified railway"	TRVINFRA-00126	High voltage Signs and safety gates at level crossings with electrified railways, version 1.0
TDOK 2014:0590 "BVS 544.22201 - Computer-based signalling centres - management of systems and installations"	TDOK 2014:0590	BVS 544.22201 - Computer-based signal boxes - management of systems and installations, version 6.0
TDOK 2014:0487 "BVS 544.93301 - Signalling functional requirements, Signalling functional requirements for the procurement of signal boxes, models 85 and 95".	TDOK 2014:0487	BVS 544.93301 - Signalling functional requirements, Signalling functional requirements for the procurement of signal boxes, models 85 and 95, version 3.0
TRVINFRA-00301 "General design"	TRVINFRA-00301	Design in general, version 14.0
TRVINFRA-00302 "Signalling"	TRVINFRA-00302	Signalling, version 12.0
TRVINFRA-00303 "Reservation of track sections"	TRVINFRA-00303	Track section reservation, version 5.0

Created by
[Created by]
Case number
[Case number]

Document date
[Document date]

Confidentiality level
[Confidentiality level]

Designation in FB	Document ID	Title
TRVINFRA-00307 "Construction"	TRVINFRA-00307	Construction, version 9.0
TRVINFRA-00308 "Commissioning and inspection"	TRVINFRA-00308	Commissioning and inspection, version 6.0
TDOK 2014:0528 "BVS 544.94008 – Qualifications, Signal Safety Inspector and trainer for signal safety inspectors"	TDOK 2014:0528	BVS 544.94008 – Qualifications, Signal Security Inspector and Signal Security Inspector Trainer, version 3.0
TDOK 2014:0498 "BVS 544.94009 – Qualification, Commissioning Inspector signalling technology"	TDOK 2014:0498	BVS 544.94009 – Qualification, Commissioning Inspector for signalling technology, version 4.0
BVS 728 "Traffic information for passengers at and near the operational site – standard for traffic information equipment"		BVS 728 "Traffic information for passengers at and near the operational site – standard for traffic information equipment"
TRVINFRA-00063 "Low-voltage Technical Building System Description"	TRVINFRA-00063	Low Voltage Technical Building System Description, version 10.0
TRVINFRA-00051 "General Train and Locomotive Heating System System Description"	TRVINFRA-00051	General Train and Locomotive Heating System System description, version 2.0
"BVS 1585.005 Standard sections for the track"	TDOK 2015:0198	BVS 1585.005 - Standard sections for the track, version 2.0
"Points Design Manual"	TDOK 2013:0478	Points Design Manual, version 4.0
TRVINFRA-00146 "High Voltage Designations for Disconnectors and Other Equipment"	TRVINFRA-00146	High Voltage Designations for Disconnectors and Other Objects, version 2.0
TRVINFRA-00141 "Low Voltage Track Switch Heating Control with IMSE WebMasterPro System description"	TRVINFRA-00141	Low Voltage Track Switch Heating Control with IMSE WebMasterPro System Description, version 3.0
TRVINFRA-00144 "Catenary Wiring"	TRVINFRA-00144	Overhead contact line wiring, version 1.0
Facility data – Coding of geographical objects – Railways	TDOK 2019:0215	TDOK 2019:0215 Facility data the facility – Coding of geographical objects – Railway, version 9.0

Created by
[Created by]
Case number
[Case number]

Document date
[Document date]

Confidentiality level
[Confidentiality level]

Name in FB	Document ID	Title
TDOK 2013:0689 "DETECTORS – Requirements for the selection of detector locations".	TDOK 2013:0689	DETECTORS – Requirements for the selection of detector locations, version 3.0
TDOK 2014:0065 "Physical security at the Swedish Transport Administration".	TDOK 2014:0065	Physical security at the Swedish Transport Administration, version 4.0
TDOK 2018:0640 "Cable Ducting".	TDOK 2018:0640	Cable ducting, version 1.0
TRVINFRA-00044 "Electrical power distribution systems – Connection of remote control units to the Geld-ICS environment via IEC 870-5-104", version 1.0	TRVINFRA-00044	"Electrical control system: Connection of remote control units to the Geld-ICS environment via IEC 870-5-104", version 1.0
TRVINFRA-00127 "General Lightning protection measures for power supply to railway installations"	TRVINFRA-00127	General Lightning protection measures for power supply to railway installations, version 2.0
TRVINFRA-00052 "Electric traction control system: Signal exchange between power supply facilities and the electric traction control system System description"	TRVINFRA-00052	Electric traction control system Signal exchange between power supply facilities and the electric traction control system System description, version 1.0
TRVINFRA-00151 "Lighting in the railway environment"	TRVINFRA-00151	Lighting in railway environments, version 1.0
"BVS 1524.210 "Butt welding. Thermite and mould welding"	TDOK 2014:0548	BVS 1524.210 – Joint welding, thermite and mould welding, version 1.0
TRVINFRA-00088 "Catenary Overhead line 15 kV System Description"	TRVINFRA-00088	Catenary and service line 15 kV System Description, version 1.0
"Routing of cables and cable crossings within or adjacent to railway lines"	TDOK 2014:0945	Laying of cables and cable crossings within or adjacent to railway lines, version 1.0
"Safety inspection – authorisation management"	TDOK 2013:0195	"Safety inspection – authorisation management", version 5.0
TRVINFRA-00140 "General Application of the high-voltage regulations in the design of the Swedish Transport Administration's railway facilities"	TRVINFRA-00140	General Application of the high-voltage regulations in the design of the Swedish Transport Administration's railway facilities, version 1.0
BVS 543.36323 TECHNICAL REGULATIONS, Electrical power installations,	TDOK 2014:0880	TDOK 2014:0880 "BVS 543.36323", TECHNICAL REGULATIONS, Electrical power installations,

Created by
[Created by]
Case number
[Case number]

Document date
[Document date]

Confidentiality level
[Confidentiality level]

Designation in FB	Document ID	Title
Distribution transformers for auxiliary power lines		Distribution transformers for auxiliary power lines, version 1.0
TRVINFRA-00077 "Contact wire S 4.9/5.9 System description"	TRVINFRA-00077	Contact wire S 4.9/5.9 System description", version 3.0
TRVINFRA-00078 "Overhead contact line ST 7.1/7.1 System description"	TRVINFRA-00078	Overhead contact line ST 7.1/7.1 System description, version 3.0
TRVINFRA-00079 "ST 9.8/9.8 Catenary System Description"	TRVINFRA-00079	ST 9.8/9.8 Catenary System Description, version 3.0
TRVINFRA-00080 "ST 9.8/11.8 Catenary System Description"	TRVINFRA-00080	ST 9.8/11.8 Catenary System Description, version 3.0
TRVINFRA-00081 "Overhead contact line SYT 7.0/9.8 System description"	TRVINFRA-00081	Catenary SYT 7.0/9.8 System description, version 3.0
TRVINFRA-00082 "SYT 9.8/9.8 Catenary System Description"	TRVINFRA-00082	Catenary SYT 9.8/9.8 System description, version 3.0
TRVINFRA-00083 "ST 15/15 Catenary System Description"	TRVINFRA-00083	ST 15/15 overhead contact line System Description, version 3.0
TRVINFRA-00084 "Overhead contact line SYT 15/15 System description"	TRVINFRA-00084	Catenary SYT 15/15 System Description, version 5.0
TRVINFRA-00092 "SYT 21/27 Catenary System Description"	TRVINFRA-00092	Catenary SYT 21/27 System Description, version 1.0
TRVINFRA-00136 "Overhead contact line foundations and Stay Anchoring"	TRVINFRA-00136	Catenary Foundation and Stay Anchoring, version 1.0
TDOK 2014:0716 "BVS 1518.4004" Electrical power installations. Aluminium cable for protective and operational earthing"	TDOK 2014:0716	TDOK 2014:0716 "BVS 1518.4004" Electrical power installations. Aluminium cable for protective and operational earthing, version 1.0
TRVINFRA-00049 "Low-voltage 1 kV distribution network System description".	TRVINFRA-00049	Low-voltage 1 kV distribution network System description" ver 2.0.
TRVINFRA-00059 "Low-voltage Uninterruptible power supply – UPS System description".	TRVINFRA-00059	Low-voltage Uninterruptible Power Supply – UPS System Description, version 1.0

Created by
[Created by]
Case number
[Case number]

Document date
[Document date]

Confidentiality level
[Confidentiality level]

Name in FB	Document ID	Title
TRVINFRA-00053 "Stations: Design and Construction – Project Planning".	TRVINFRA-00053	Stations Design and Implementation Design, version 1.0
TRVINFRA-00133 "Electrical Power Distribution Systems Interlocking and operating conditions".	TRVINFRA-00133	Electrical Control System Interlocking and Operating Conditions, version 1.0
TRVINFRA-00134 "Stations: Metal-enclosed switchgear".	TRVINFRA-00134	Metal-enclosed switchgear stations, version 1.0
TRVINFRA-00057 "Relay protection stations".	TRVINFRA-00057	Stations Relay protection, version 2.0
TRVINFRA-00174 "Installation of GSM-R equipment for fixed telephony in power supply facilities".	TRVINFRA-00174	Installation of GSM-R equipment for fixed telephony in power supply facilities, version 1.0
TRVINFRA-00070 "Station Designations".	TRVINFRA-00070	Station Designations, version 2.0
TRVINFRA-00138 "General EMC requirements for electrical equipment in the Swedish Transport Administration's facilities".	TRVINFRA-00138	General EMC requirements for electrical equipment in the Swedish Transport Administration's facilities, version 2.0
TDOK 2014:0675 "BVS 1543.14242 - Electrical power installations. Energy metering in power installations".	TDOK 2014:0675	BVS 1543.14242 - Electrical power installations. Energy metering in electrical power installations, version 1.0
TRVINFRA-00061 "Stations: Analogue interfaces between rotating converters and fixed stations. System description".	TRVINFRA-00061	Stations Analogue interfaces between rotating converters and fixed stations System description, version 1.0
TDOK 2013:0433 "Procedures before and after the transport of mobile converters".	TDOK 2013:0433	Procedures before and after transport of mobile converters, version 3.0
TDOK 2013:0407 "Transport of mobile inverters".	TDOK 2013:0407	Transport of mobile inverters, version 3.0
TDOK 2013:0670 "BVS 1543.17000 – Electrical power installations, Converters for track power supply".	TDOK 2013:0670	BVS 1543.17000 – Electrical power installations, Converters for track power supply, version 1.0
TRVINFRA-00055 "Emergency disconnection and total shutdown".	TRVINFRA-00055	Emergency shutdown and total stop, version 2.0

Created by
[Created by]
Case number
[Case number]

Document date
[Document date]

Confidentiality level
[Confidentiality level]

Designation in FB	Document ID	Title
TDOK 2013:0640 "Electrical power installations. Documentation requirements for power supply installations".	TDOK 2013:0640	"Electrical power installations. Documentation requirements for power supply installations", version 6.0.
TRVINFRA-00135 "Substations Substation control systems Larger facilities".	TRVINFRA-00135	Stations Station control systems Larger facilities, version 4.0
TRVINFRA-00389 "Electrical power plant. Computerised HMI in power stations"	TRVINFRA-00389	Electrical power plant. Computerised HMI in electrical power plants. Version 1.0
TRVINFRA-00370 "Electrical power plant, Application of SS EN 61850"	TRVINFRA-00370	Electrical power plant, Application of SS EN 61850, version 1.0
TRVINFRA-00168 "Substations – Substation control systems for simple power supply installations".	TRVINFRA-00168	Substations Substation control systems for simpler power supply installations, version 5.0
TRVINFRA-00143 "Converter Station Site and Building Requirements for Static Converters Facility description".	TRVINFRA-00143	Converter station Site and building requirements for static converters Facility description, version 2.0
TRVINFRA-00056 "Stations Local power systems System description".	TRVINFRA-00056	Stations Local Power Systems System Description, version 1.0
TRVINFRA-00128 "Converter station and transformer station, 3-phase 50 Hz and 1-phase 16 2/3 Hz, outdoor switchgear with design voltage between 52 kV and 145 kV".	TRVINFRA-00128	Converter station and transformer station, 3-phase 50 Hz and 1-phase 16 2/3 Hz outdoor switchgear with a design voltage between 52 kV and 145 kV, version 1.0
TRVINFRA-00134 "Metal-enclosed switchgear".	TRVINFRA-00134	Metal-enclosed switchgear, version 1.0
TDOK 2013:0680 "BVS 543.14512 - Feeder transformer for auxiliary power line in the Swedish Transport Administration's	TDOK 2013:0680	BVS 543.14512 - Feeder transformer for auxiliary power lines in the Swedish Transport Administration's power supply facilities,

Created by
[Created by]
Case number
[Case number]

Document date
[Document date]

Confidentiality level
[Confidentiality level]

Designation in FB	Document ID	Title
power supply facilities „Technical Regulations”.		Technical regulations, version 1.0
TDOK 2021:0437 Design Manual for Low-Voltage Installations and technical buildings for railways.	TDOK 2021:0437	TDOK 2021:0437 Design Manual for Low-Voltage Installations and technical buildings for railways. Version 2.0
UHte 16-083 “Summary of signal exchange within electrical power installations and with overhead contact line systems”.	UHte 16-083	UHte 16-083 “Summary of signal exchange within electrical power installations and with overhead contact line systems”, version 1.5. The UHte document is requested from the client.
TRV 2021/99388 “Interlock function for motor control units for railway isolators”.	TRV 2021/99388	TRV 2021/99388 “Interlocking function for motor control units for railway isolators”.
TDOK 2014:0507 “BVS1543.11601 Power supply installations Autotransformer system system description”.	TDOK 2014:0507	BVS1543.11601 Power supply installations Autotransformer systems – system description, ver 2.0
TRVINFRA-00304 “Level crossings”.	TRVINFRA- 00304	Level crossings, version 15.0
TRVINFRA-00399 “Requirements Physical barrier railway”	TRVINFRA- 00399	Requirements for physical barriers on railways, version 1.0
TRVINFRA-00367 “Design of CCTV in railway facilities”	TRVINFRA- 00367	Design of CCTV surveillance in railway facilities, version 3.0
TRVINFRA-00358 “Requirements design and characteristics”	TRVINFRA- 00358	Requirements, design and characteristics, version 1.0
TRVINFRA-00332 “Technical requirements for surveillance cameras in railway infrastructure”	TRVINFRA- 00332	Technical requirements for surveillance cameras in railway installations, version 2.0
TRVINFRA-00179 “Low-voltage power cable installations and marking systems for railways”	TRVINFRA- 00179	Low-voltage power cable installations and labelling system for railways, version 1.0
TRVINFRA-00178 “High-voltage cable systems”	TRVINFRA- 00178	High-voltage cable systems, version 1.0
TRVINFRA-00173 “Electrical Power Plant Electrical Safety Earthing of	TRVINFRA- 00173	Electrical Power Plant Electrical Safety Earthing of contact line at

Created by
[Created by]
Case number
[Case number]

Document date
[Document date]

Confidentiality level
[Confidentiality level]

Designation in FB	Document ID	Title
contact line during rescue operations in tunnels”		rescue operation in a tunnel; version 1.0
TRVINFRA-00169 “High Voltage Auxiliary Power System 50Hz”	TRVINFRA-00169	High-voltage auxiliary power system 50Hz, version 1.0
TRVINFRA-00166 “Low Voltage Design of Local Control Rooms at Manned stations/operating sites”	TRVINFRA-00166	Low Voltage Design of local control rooms at manned stations/operating sites, version 1.0”
TRVINFRA-00162 “Catenary Update of wiring diagrams and group diagrams for the Swedish Transport Administration’s catenary and auxiliary power line installations”	TRVINFRA-00162	Overhead contact line Update of connection diagrams and group diagrams for the Swedish Transport Administration’s overhead contact line and auxiliary power line installations, version 2.0
TRVINFRA-00132 “Low Voltage Electrical Equipment in Railway Tunnels System descriptions”	TRVINFRA-00132	Low-voltage electrical equipment in railway tunnels System descriptions, version 2.0
TRVINFRA-00123 “Overhead contact line: Tensioning and adjustment tables for permanently tensioned cables and cantilevers. Al212, Cu130, Cu35, FeAl99, FeAl66 cables. Cantilever adjustment”	TRVINFRA-00123	Catenary Tension and adjustment tables for fixed tensioned wires and cantilevers. Al212, Cu130, Cu 35, FeAl 99, FeAl 66 wire. Cantilever adjustment. Version 2.0
TRVINFRA-00114 “Overhead contact line and auxiliary power line Connection points”	TRVINFRA-00114	Overhead contact line and auxiliary power line Connection points, version 1.0
TRVINFRA-00074 “General Design of steel structures and overhead lines”	TRVINFRA-00074	General Design of steel structures and overhead lines, version 1.0
TRVINFRA-00060 “Converter Station Relay Protection and Monitoring Functions in Rotating Converters System description”	TRVINFRA-00060	Converter Station Relay protection and monitoring functions in rotating converters System description, version 1.0
TRVINFRA-00047 “Catenary	TRVINFRA-00047	Catenary Safety devices – Safety nets, version 1.0

Created by
[Created by]
Case number
[Case number]

Document date
[Document date]

Confidentiality level
[Confidentiality level]

Designation in FB	Document ID	Title
Protective devices – Safety nets”		
TRVINFRA-00046 “Catenary Anchoring, stays, supports, struts”	TRVINFRA-00046	Catenary Anchoring, stays, supports, braces, version 1.0
TRVINFRA-00045 “General Insulating fluids for transformers and other high-voltage products”	TRVINFRA-00045	General Insulating fluids for transformers and other high-voltage products, version 1.0
TRVINFRA-00043 “Overhead contact line wiring diagram”	TRVINFRA-00043	Catenary wiring diagram, version 2.0
TRVINFRA-00040 “Overhead contact line: Intersection with high-voltage power lines over and under railway or tramway”	TRVINFRA-00040	Overhead contact line crossing with high-voltage power lines over and under railway or tramway, version 1.0
TRVINFRA-00402 “Design of traffic information equipment at railway stations”	TRVINFRA-00402	TRVINFRA-00402 Design of traffic information equipment at railway stations, version 2.0
TRVINFRA-00395 “Railway Complex structure – Tunnel”	TRVINFRA-00395	TRVINFRA-00395 Railway Complex facility – Tunnel, version 1.0
TRVINFRA-00397 “Substation for the Geldsystem Control Unit”	TRVINFRA-00397	TRVINFRA-00397 Substation for the Geldsystem Control Unit, Version 1.0
TRVINFRA-00394 “Railway Design Specification Building Automation”	TRVINFRA-00394	TRVINFRA-00394 Railway Design Guide Building automation, version 1.0
TRVINFRA-00393 “Railway General requirements”	TRVINFRA-00393	TRVINFRA-00393 Railway General requirements, version 1.0
TRVINFRA-00018 “Track components”	TRVINFRA-00018	TRVINFRA-00018 Track components, version 5.0
TRVINFRA-00017 “Track switch”	TRVINFRA-00017	TRVINFRA-00017 Track switch, version 5.0
TRVINFRA-00012 “Requirements Track superstructure track system”	TRVINFRA-00012	Requirements Track Superstructure track system”, version 4.0,
TRVINFRA-00018 “Requirements Track Superstructure Track Components”	TRVINFRA-00018	Requirements Track superstructure track components, version 5.0
TRVINFRA-00013 “Requirements Track superstructure track alignment”	TRVINFRA-00013	Requirements for track superstructure track alignment, version 2.0

Created by
[Created by]
Case number
[Case number]

Document date
[Document date]

Confidentiality level
[Confidentiality level]

Designation in FB	Document ID	Title
TRVINFRA-00016 "Requirements Track superstructure welding, machining and lubrication	TRVINFRA- 00016	Requirements for track superstructure welding, machining and lubrication, version 2.0
TRVINFRA-00271 "Requirements Track superstructure technical Safety Control"	TRVINFRA- 00271	Requirements Track superstructure technical Safety control, version 2.0