

FÖRKLARINGAR

- BEFINTLIG MARKNIVÅ
- NYTT VÄGRÄCKE/GC-RÄCKE
- VK_x.xx VÄGKANT, X METER FRÅN LINJE 202-GC
- VK_GC_x.xx VÄGKANT GC-BANA, X METER FRÅN LINJE 202-GC
- VM_x.xx VÄGMITT (BEFINTLIG), X METER FRÅN LINJE 202-GC
- Ny_VM_x.xx NY VÄGMITT, X METER FRÅN LINJE 202-GC
- Bef_VM_x.xx BEFINTLIG VÄGMITT (VID VÄGMITTSFÖRSKJUTNING)
- x.xx TVÄRFALL

ANVISNINGAR

TVÄRSEKTIONER AVSER LINJE 202-GC

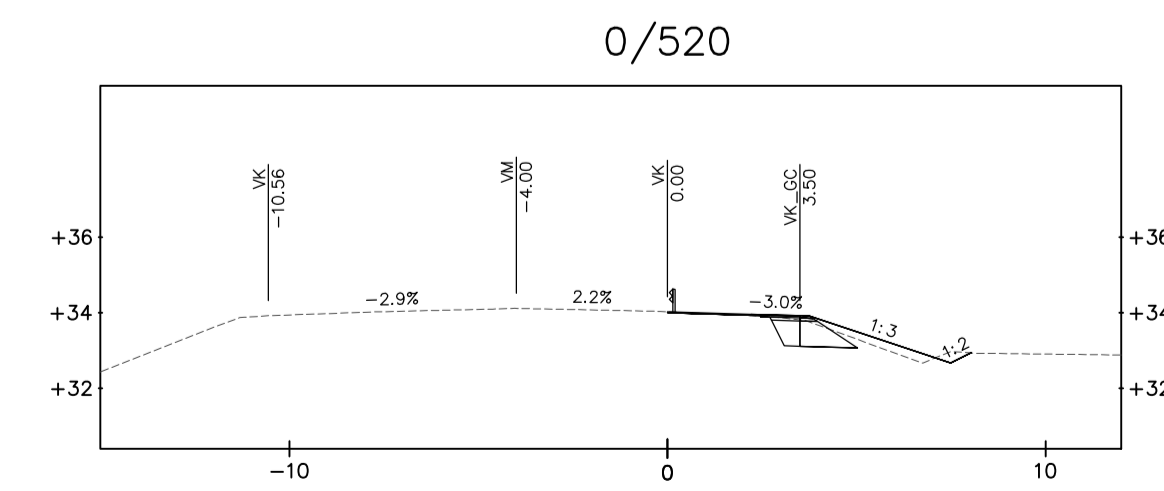
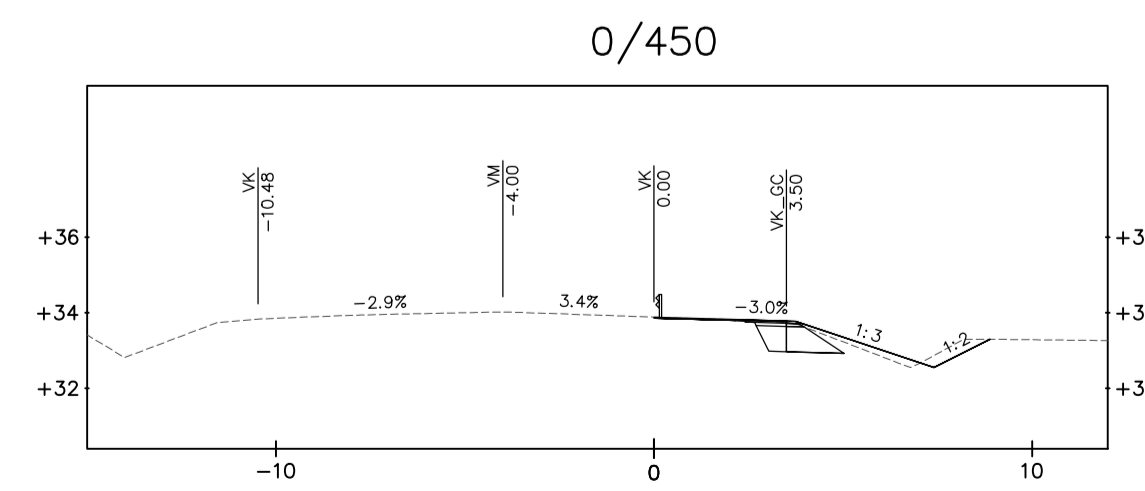
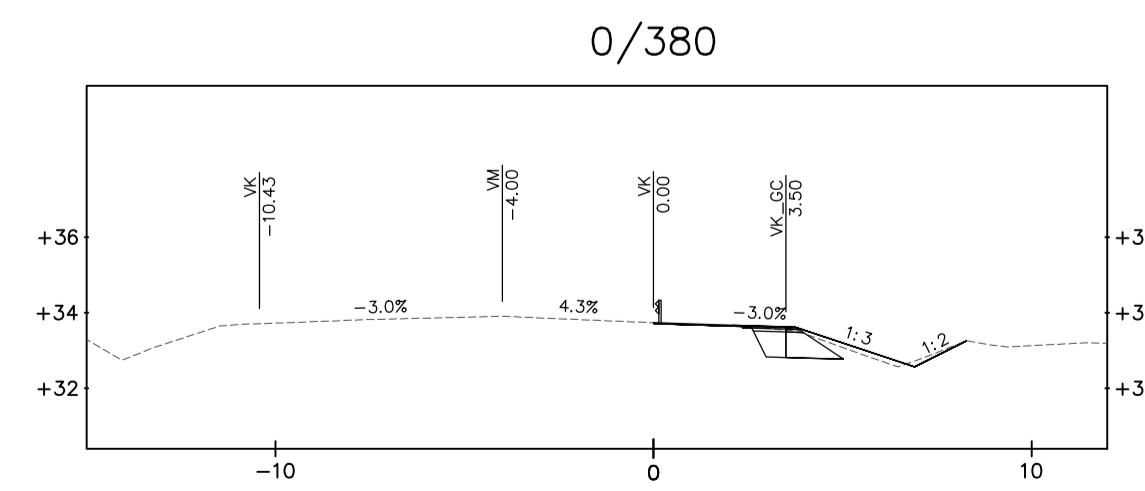
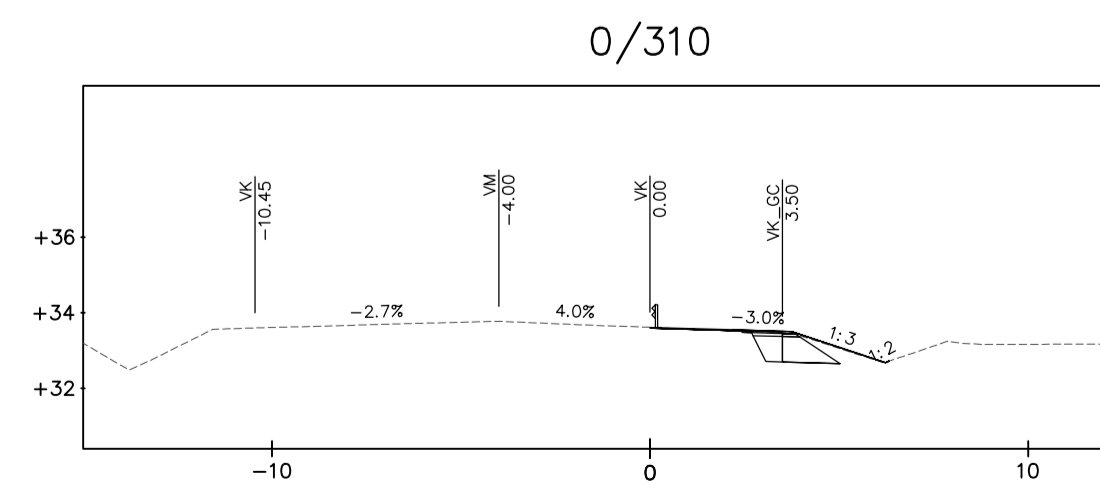
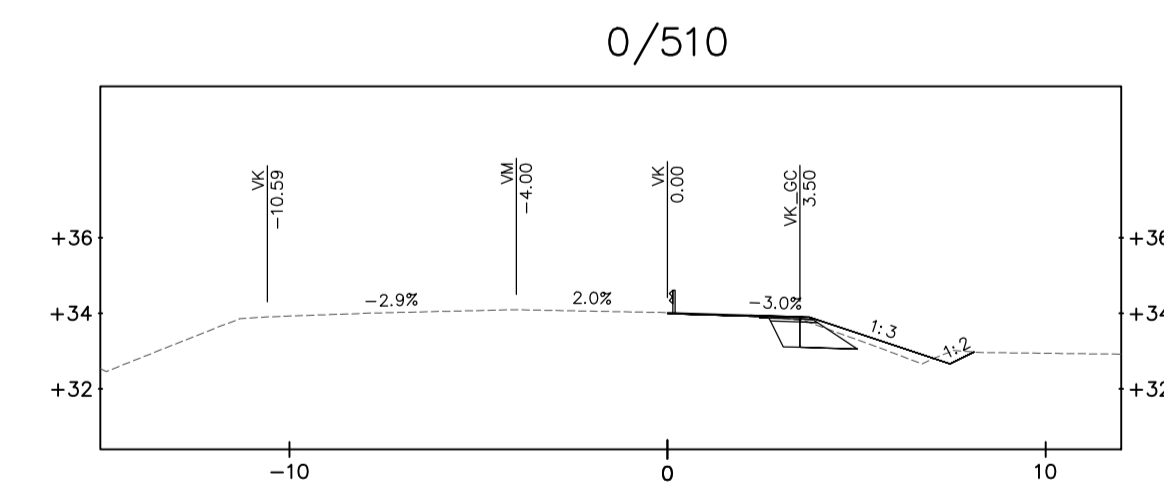
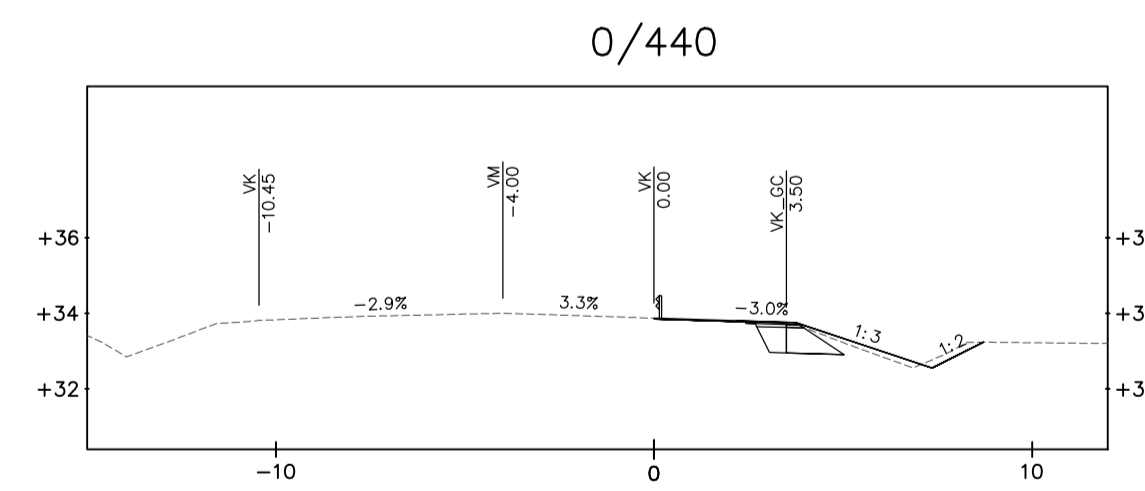
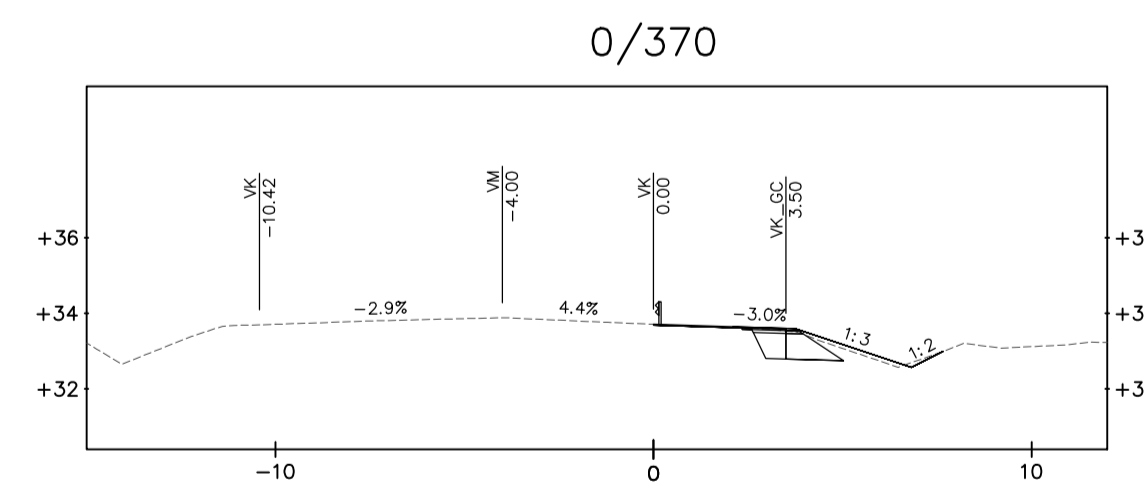
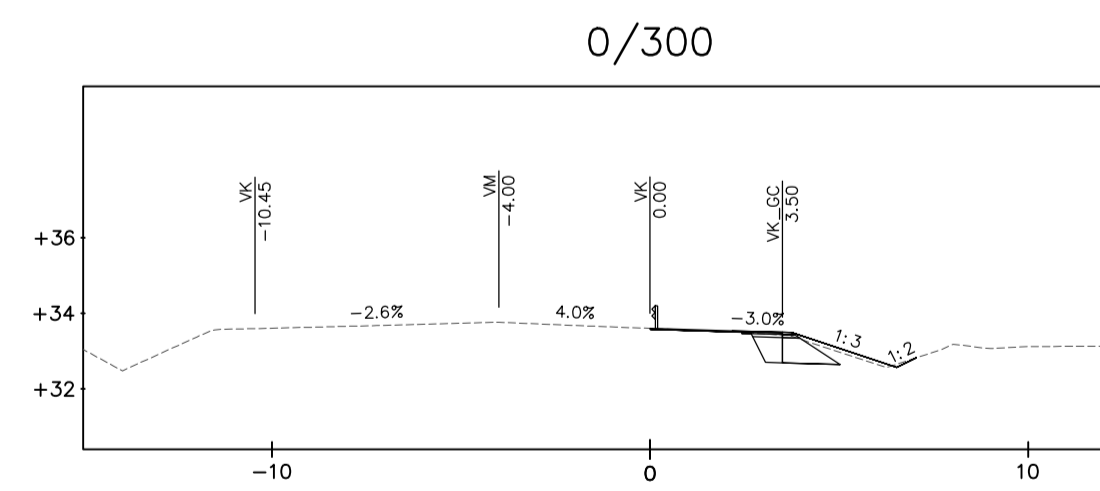
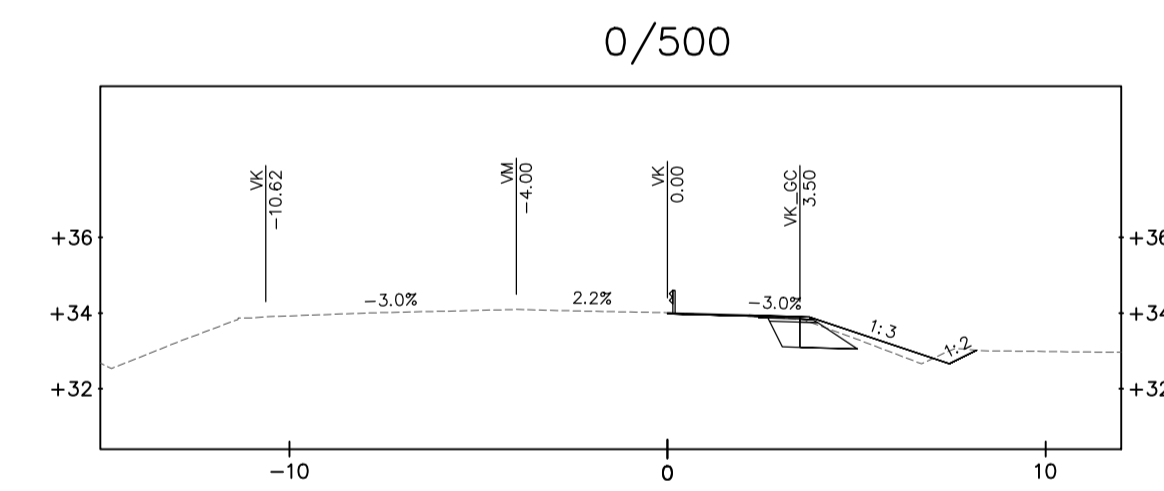
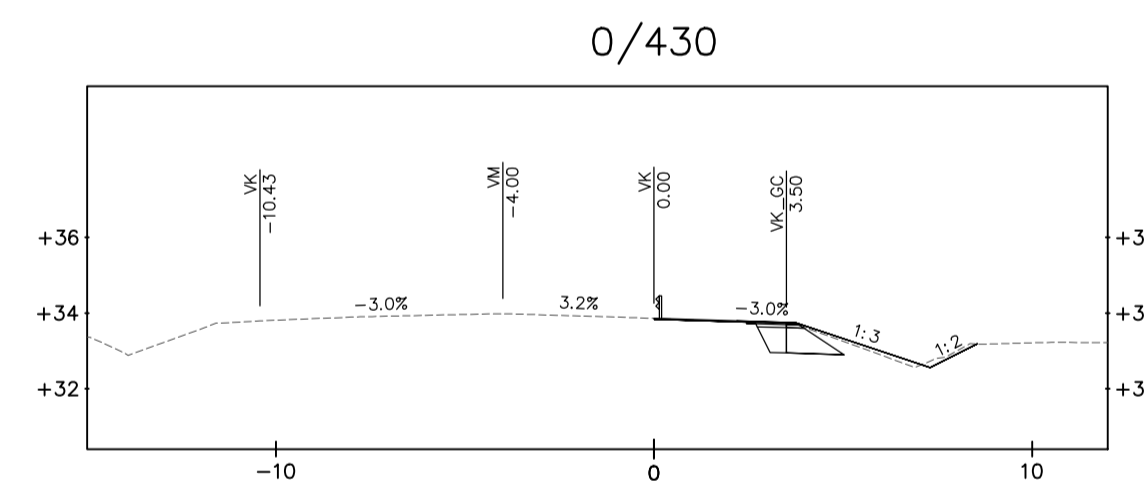
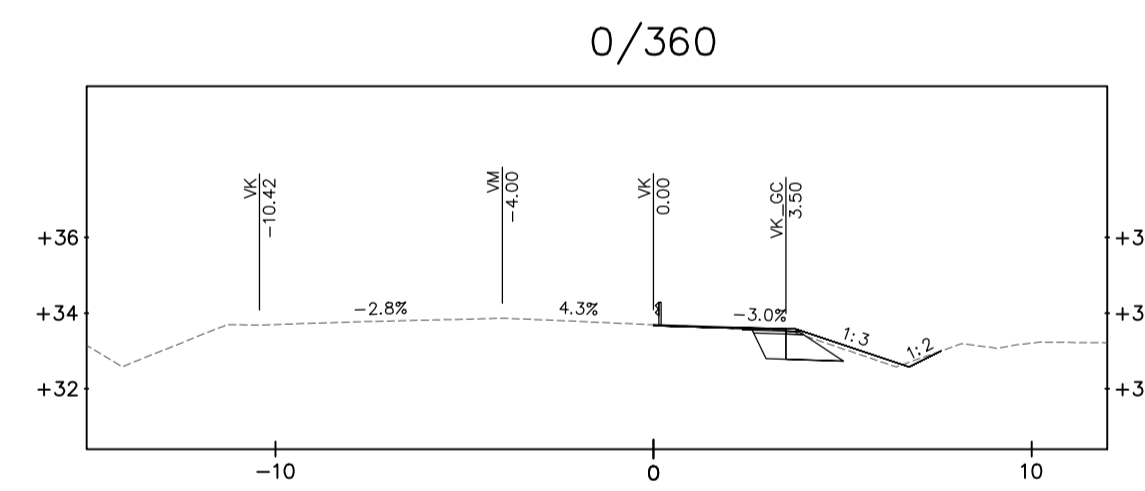
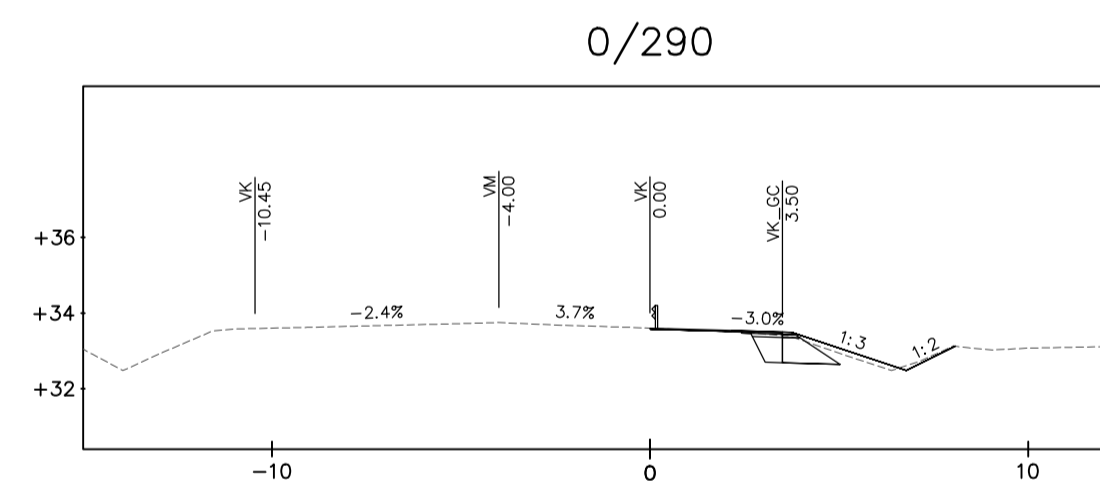
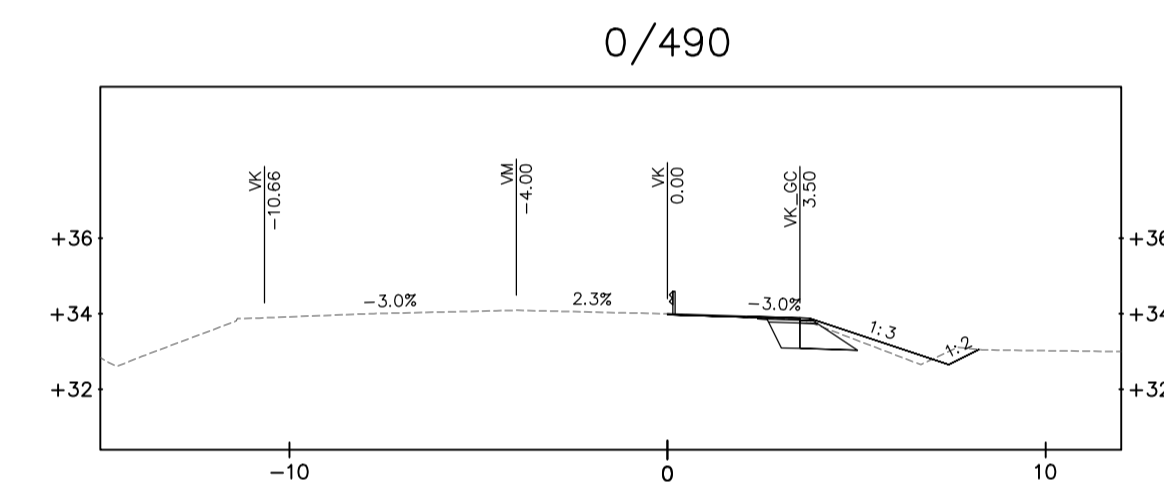
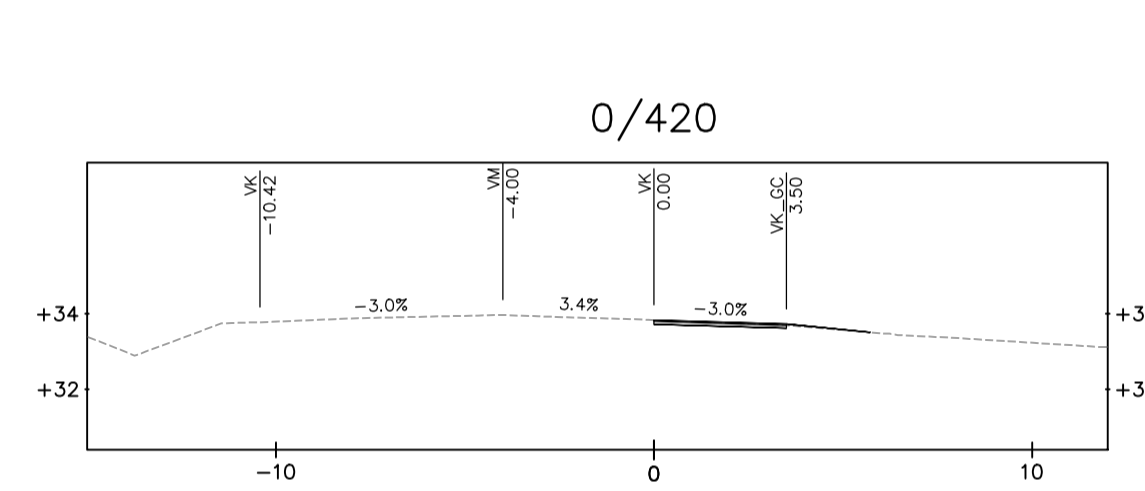
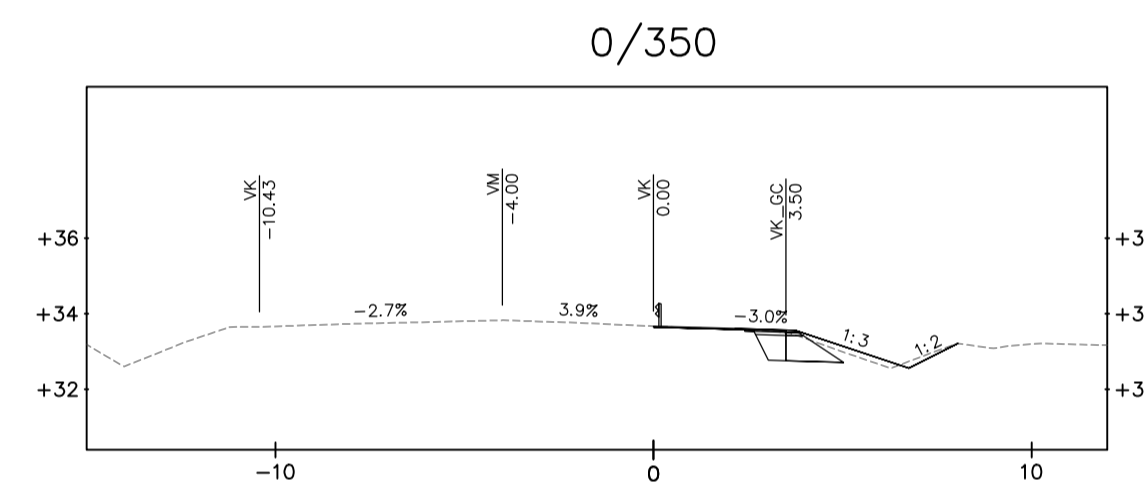
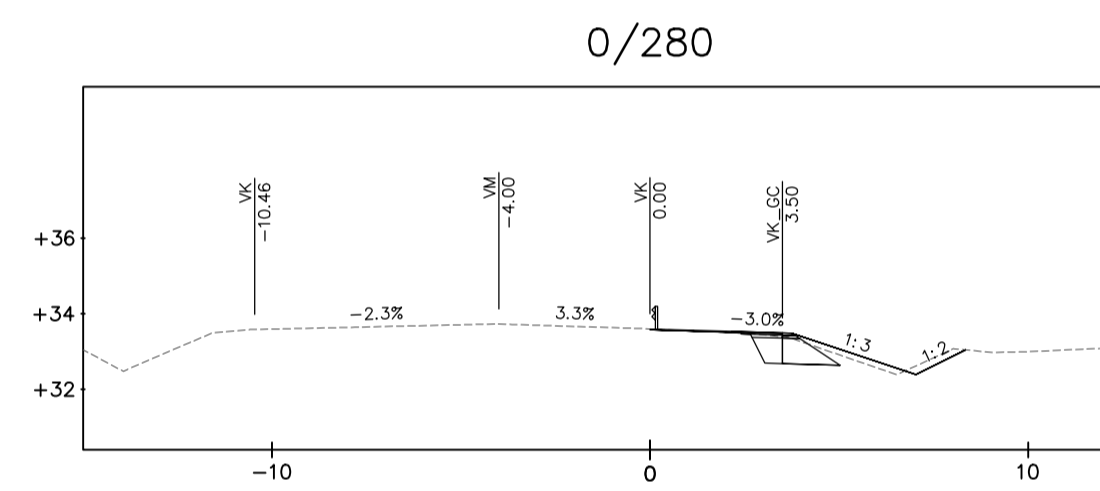
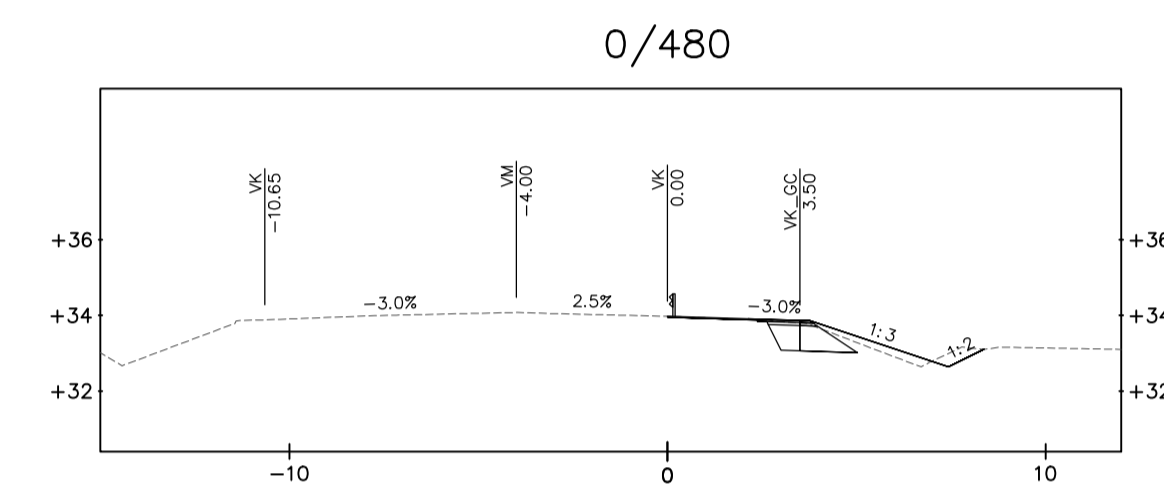
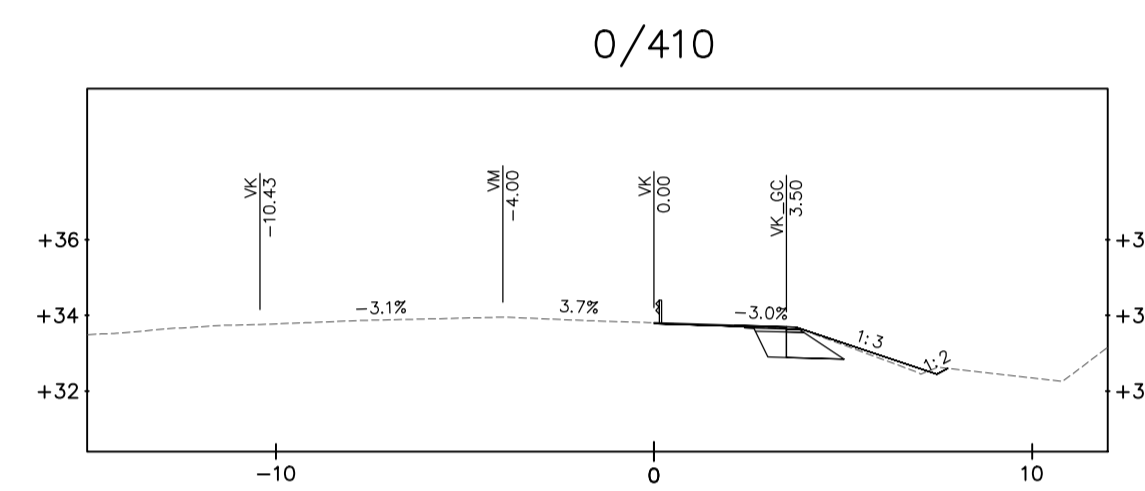
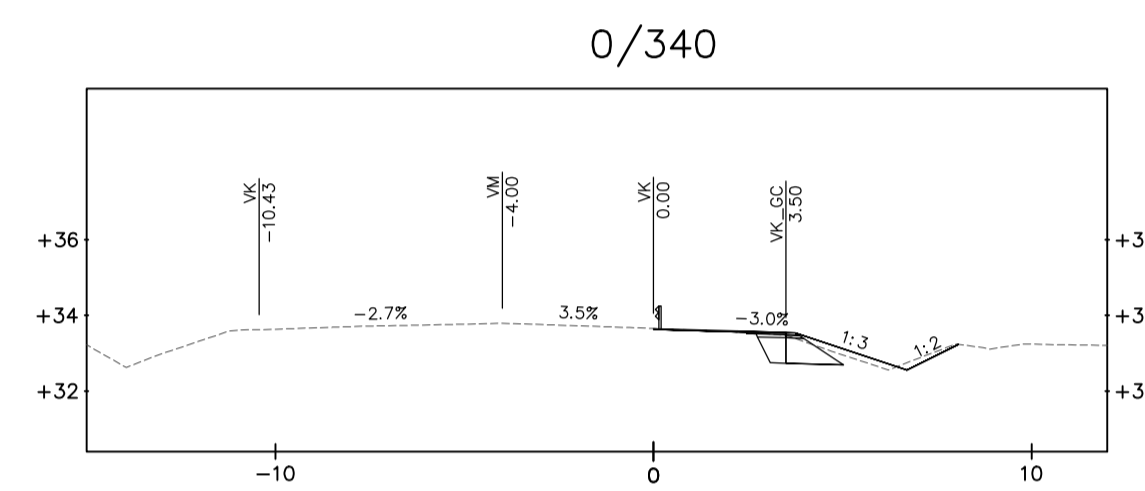
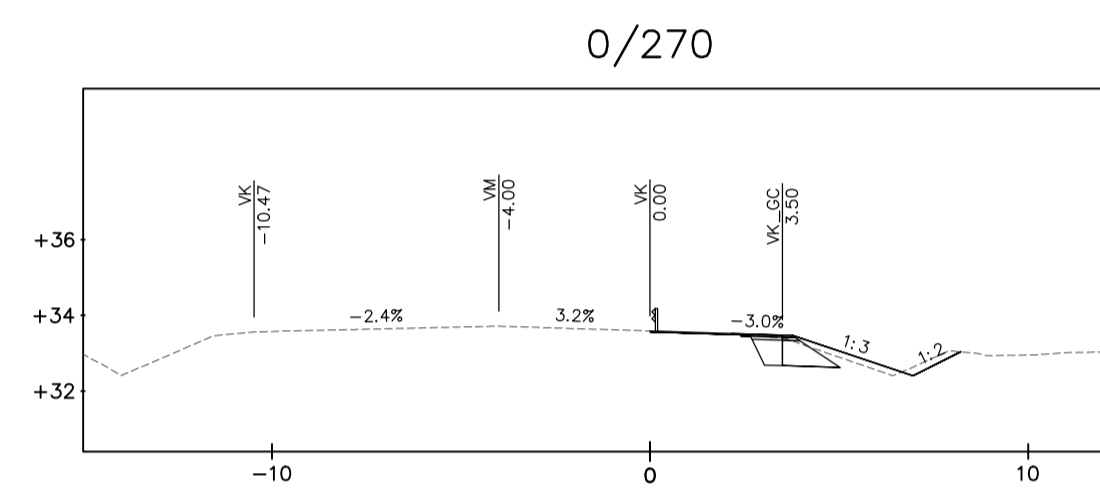
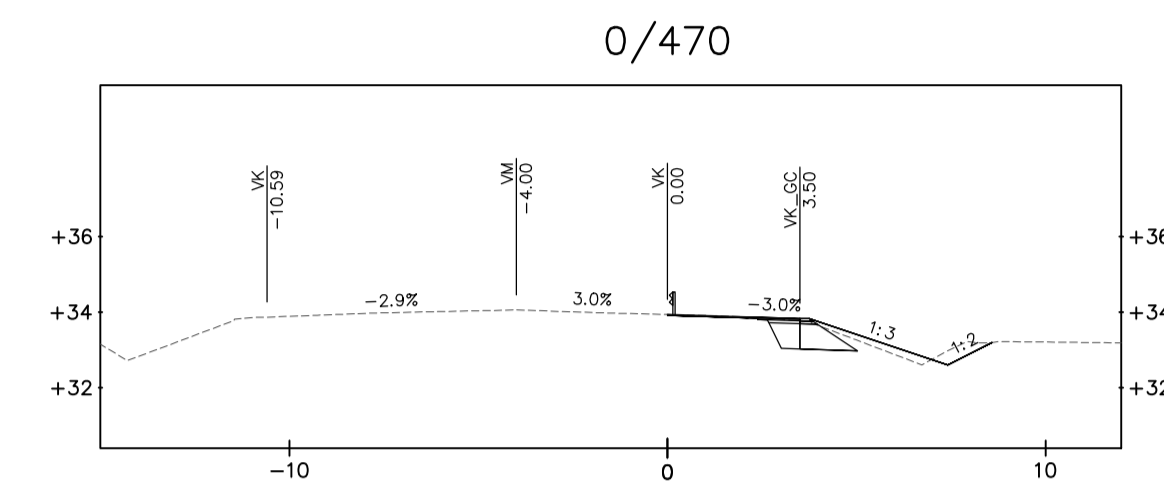
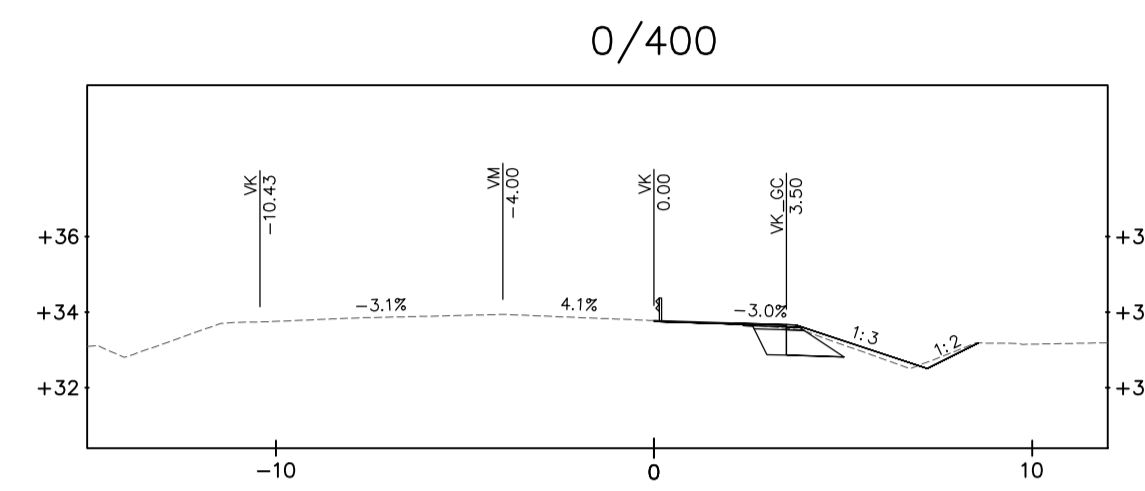
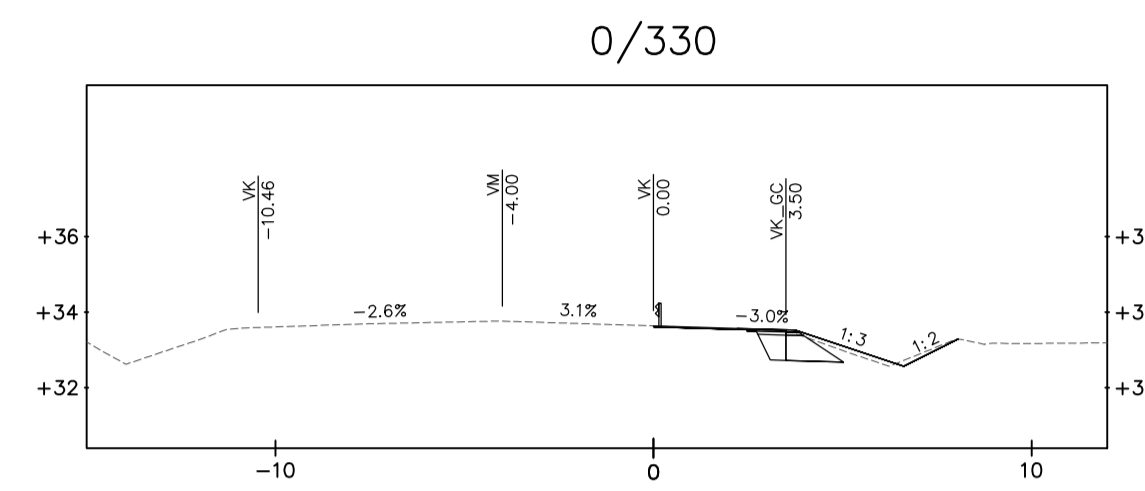
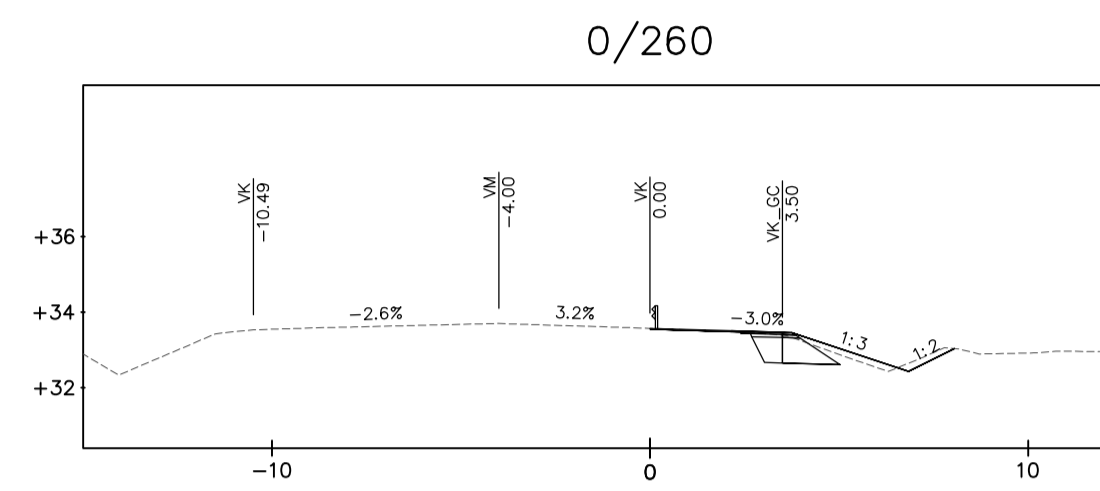
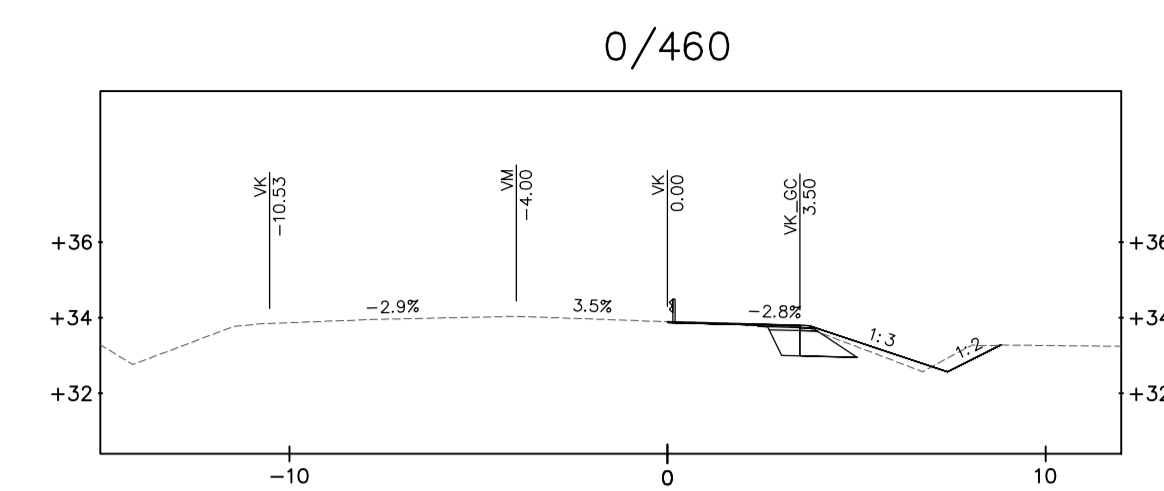
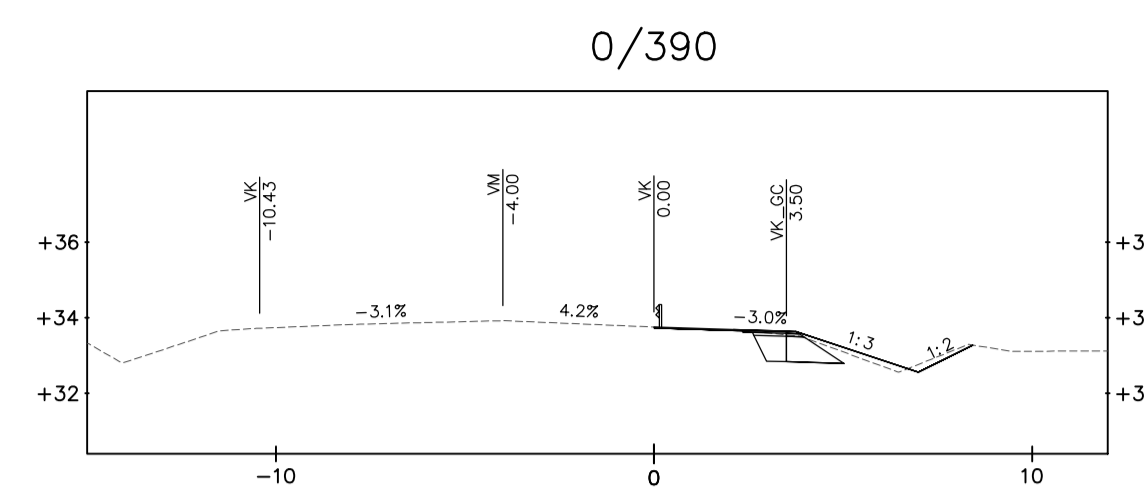
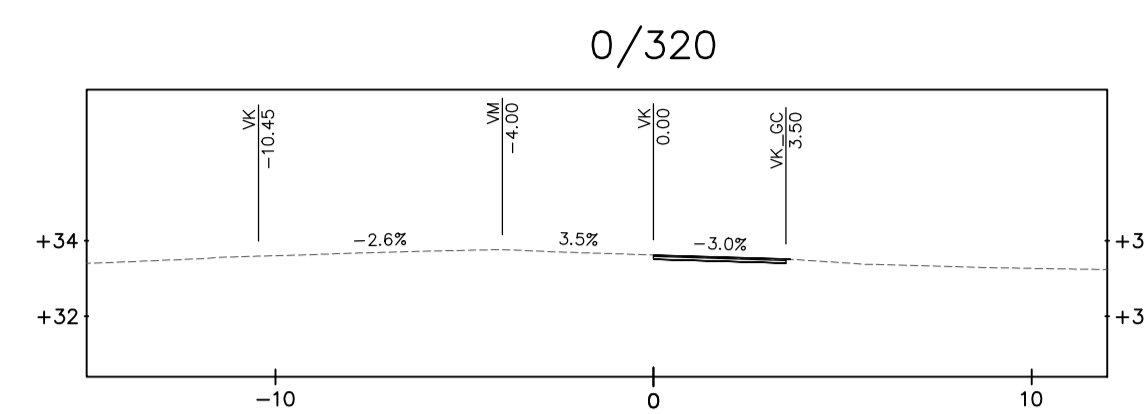
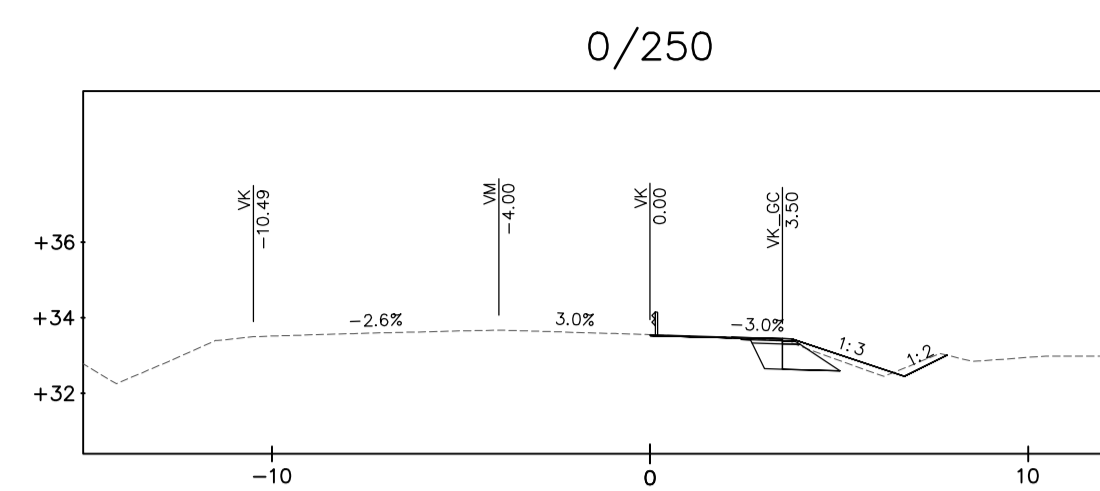

KOORDINATSYSTEM

PLAN: SWEREF 99 18 00
HÖJD: RH 2000

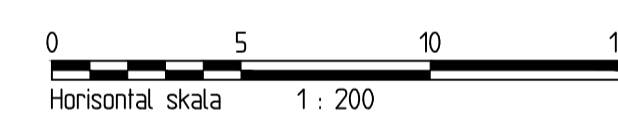

TYP AV PLAN		VÄGPLAN	
GRANSKNINGSSTATUS / SYFTE			
HANDLINGSTYP GRANSKNINGSHANDLING			
DATUM 2024-04-04		LEVERANS / ÄNDRINGS-PM	
OBJEKT GC-VÄG TIERP - TIERPS KYRKBY			
DELOMRÅDE / BANDEL TIERP			
ANLÄGGNINGSDEL TIERP - TIERPS KYRKBY			
OBJEKTNUMMER / KM 169470	KONSTRUKTIONNUMMER		
BESTÄLLARE	LEVERANTÖR		
SKAPAD AV M. VALL	UPPDRAGSNUMMER 2013741		
GODKÄND AV J. NILSSON	ÄVDELNING		
RITNINGSTYP SEKTIONS-RITNING			
TEKNIKOMRÅDE / INNEHÅLL VÄGUTFORMNING OCH TRAFIK			
BESKRIVNING TVÄRSEKTIONER LINJE 202-GC			
0/250 - 0/520			
SKALA 1:200	FORMAT A1	FÖRVALTNINGSNUMMER	
RITNINGNUMMER 2 02 T 09 02	BLAD	NÄSTA BLAD	BET