

# FÖRKLARINGAR

- BEFINTLIG MARKNIVÅ
- NYTT VÄGRÄCKE/GC-RÄCKE
- N<sub>K</sub> VÄGKANT, X METER FRÅN LINJE 202-GC
- N<sub>K</sub> GC VÄGKANT GC-BANA, X METER FRÅN LINJE 202-GC
- N<sub>M</sub> VÄGMITT (BEFINTLIG), X METER FRÅN LINJE 202-GC
- N<sub>M</sub> NY VÄGMITT, X METER FRÅN LINJE 202-GC
- B<sub>H</sub> BEFINTLIG VÄGMITT (VID VÄGMITTSFÖRSKJUTNING)
- x xx TVÄRFALL

# ANVISNINGAR

TVÄRSEKTIONER AVSER LINJE 202-GC

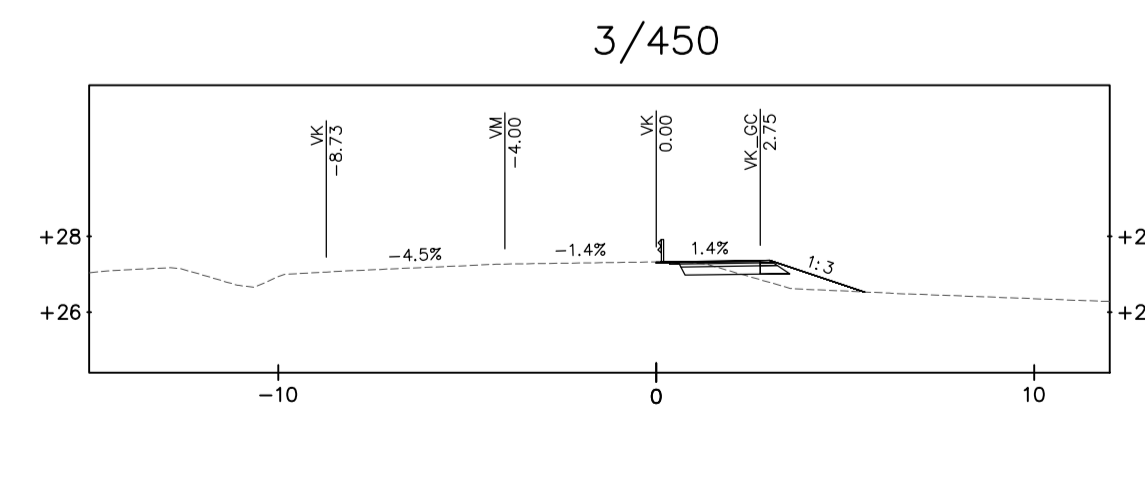
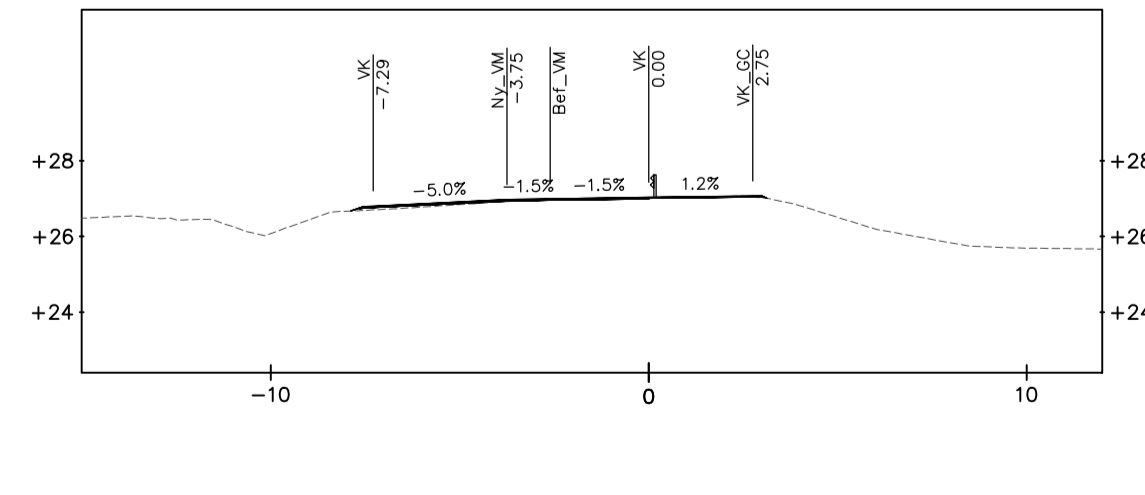
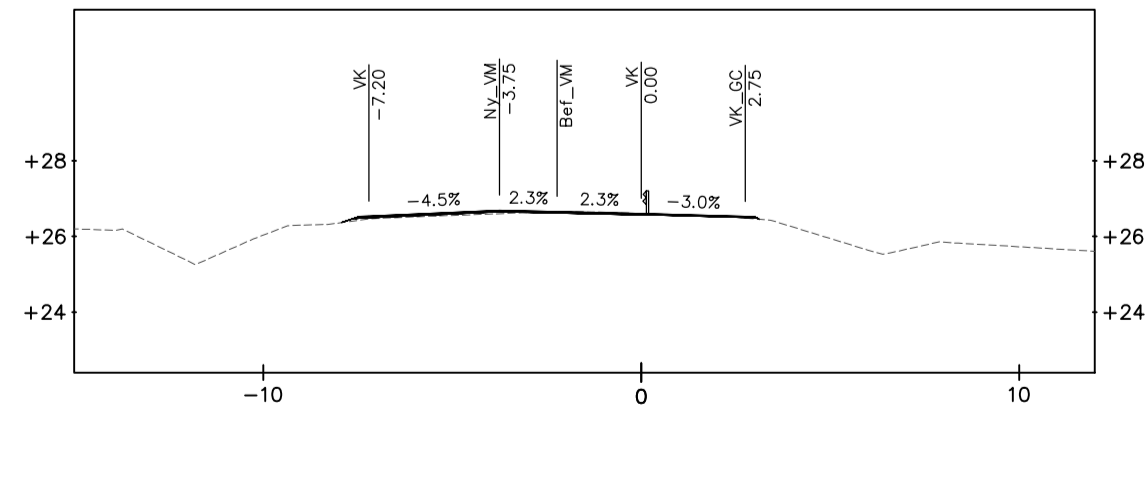
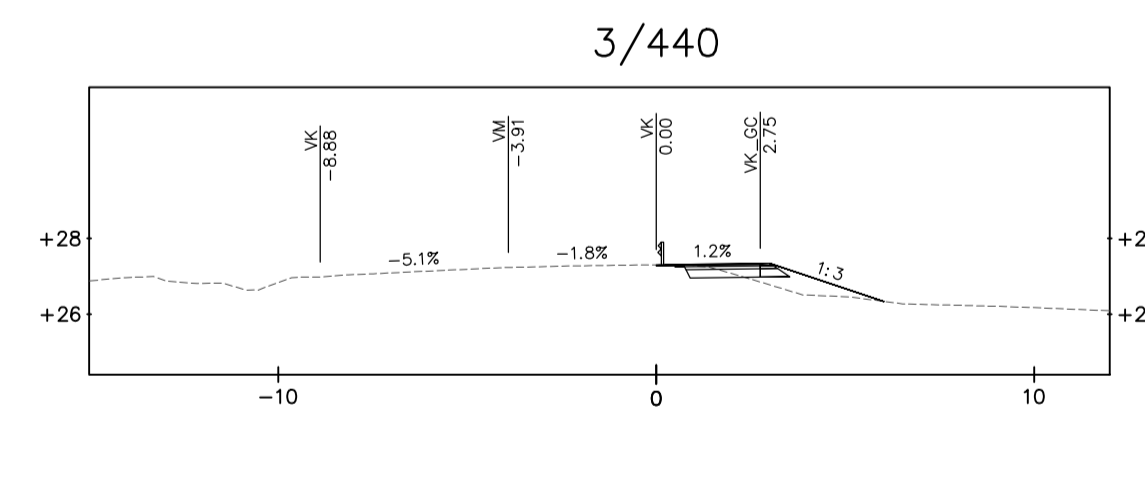
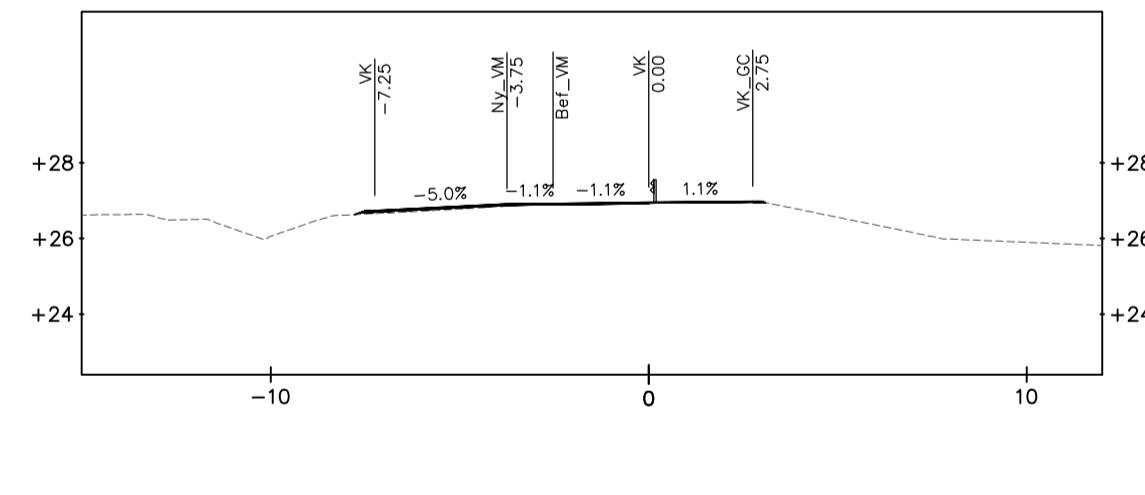
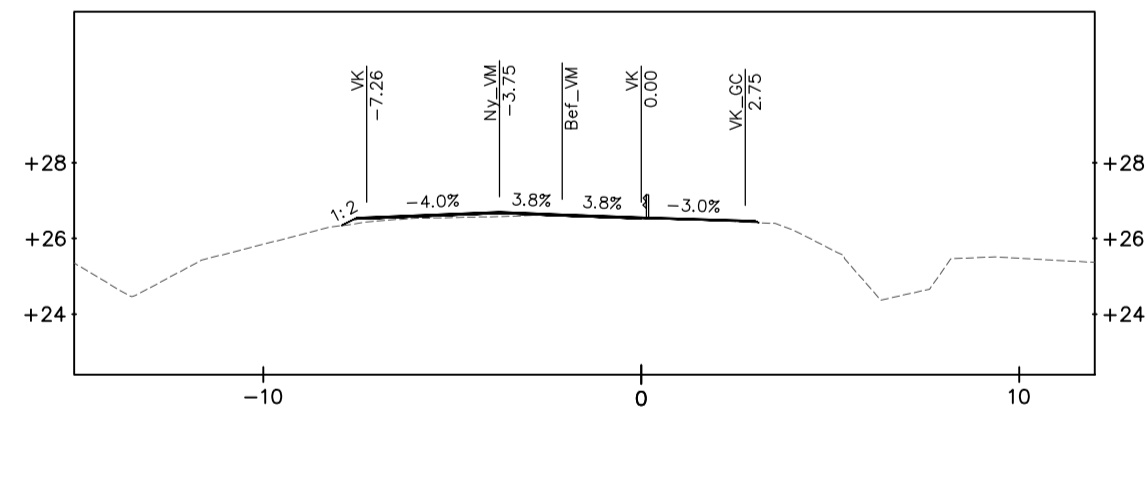
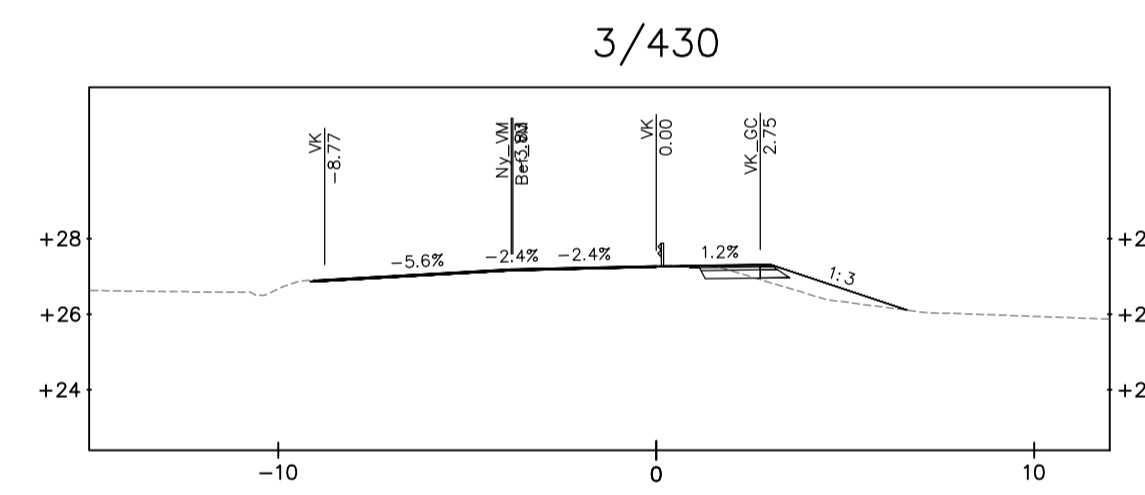
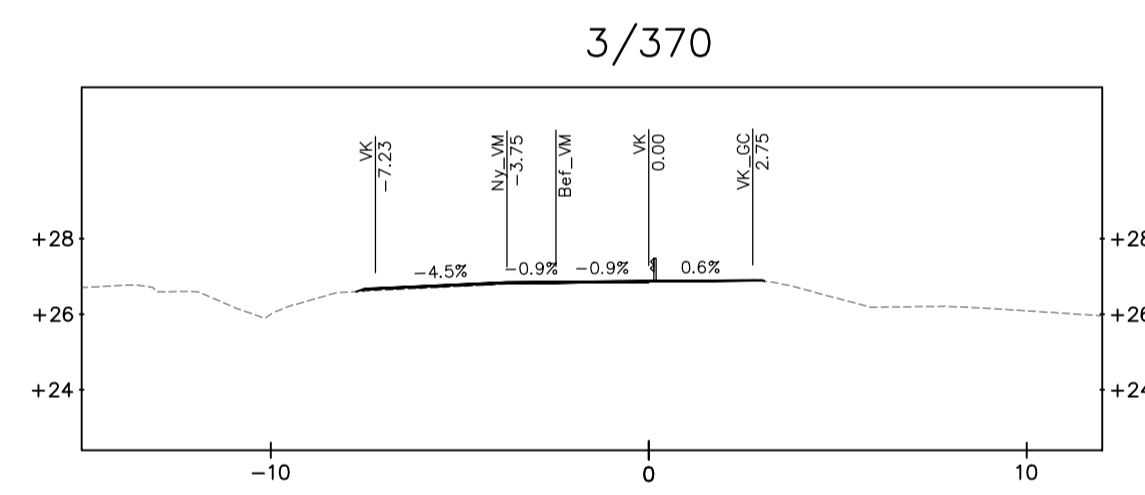
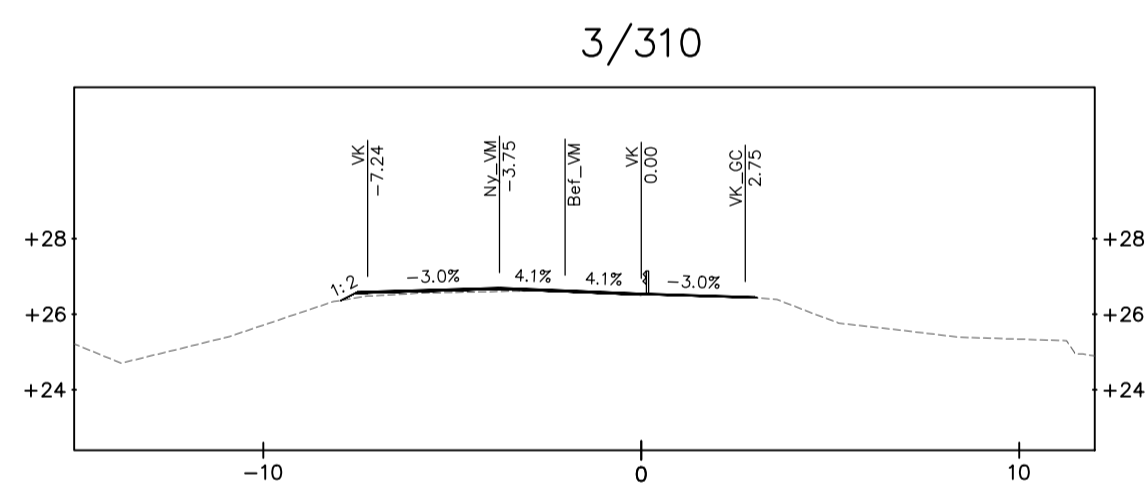
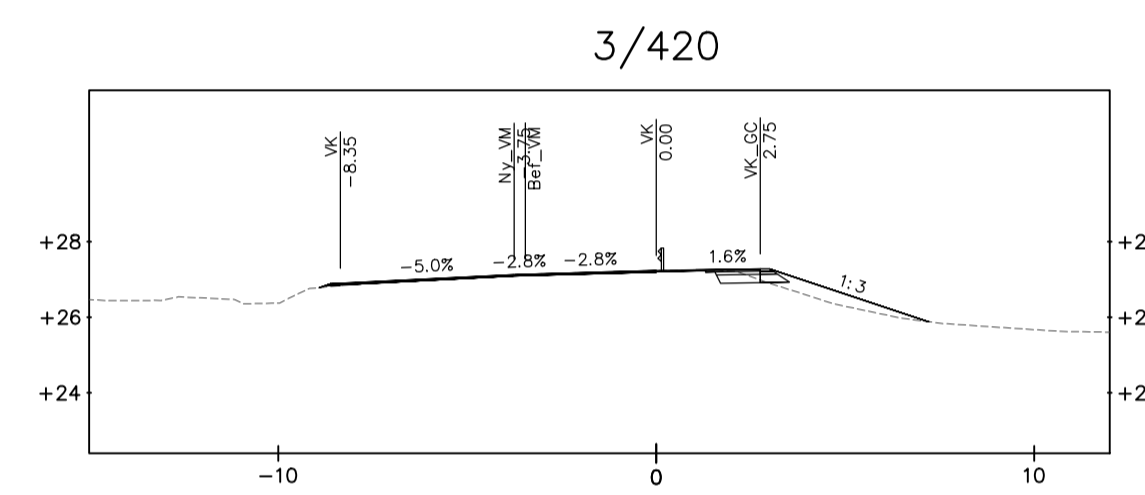
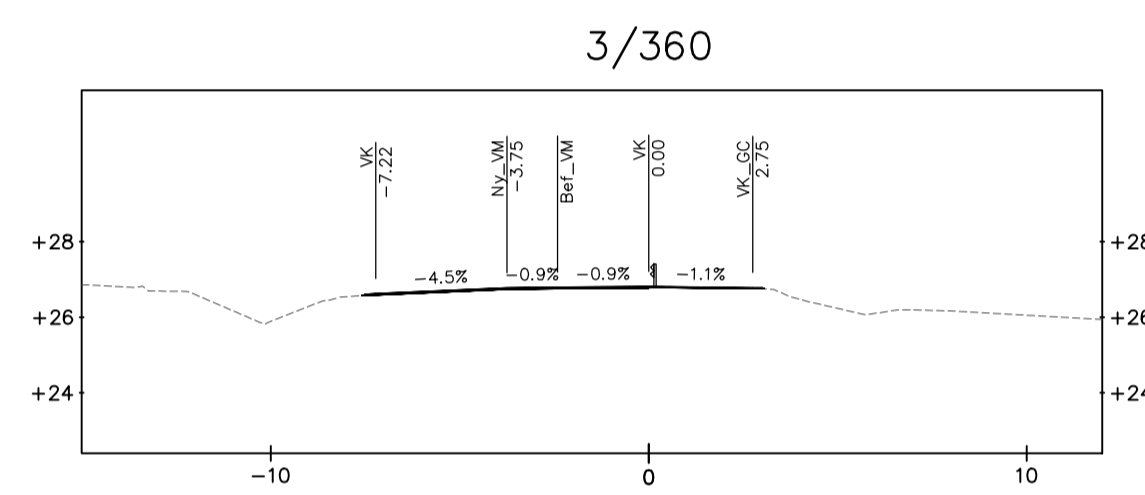
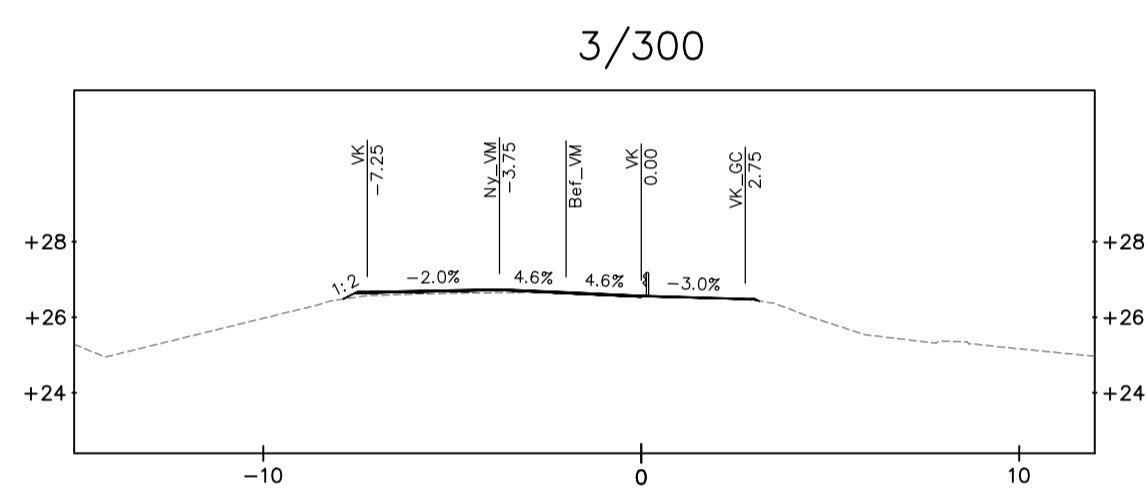
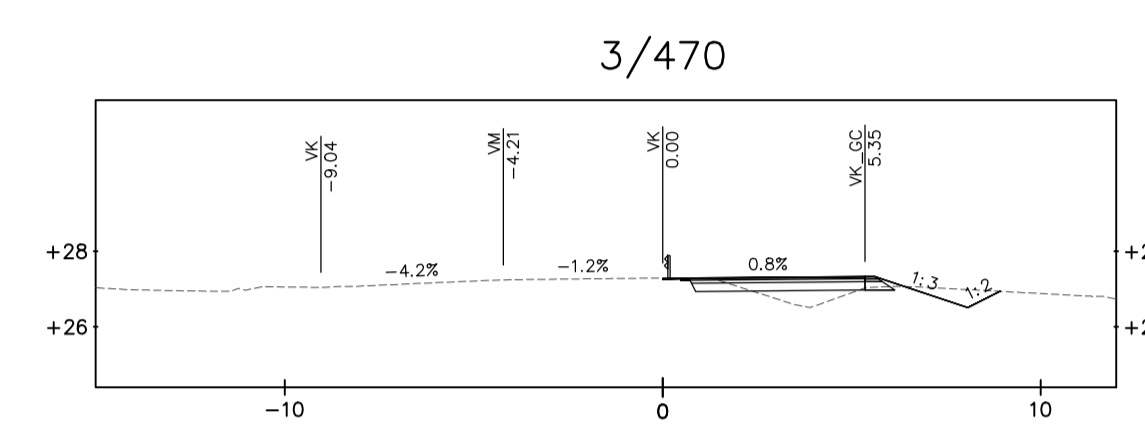
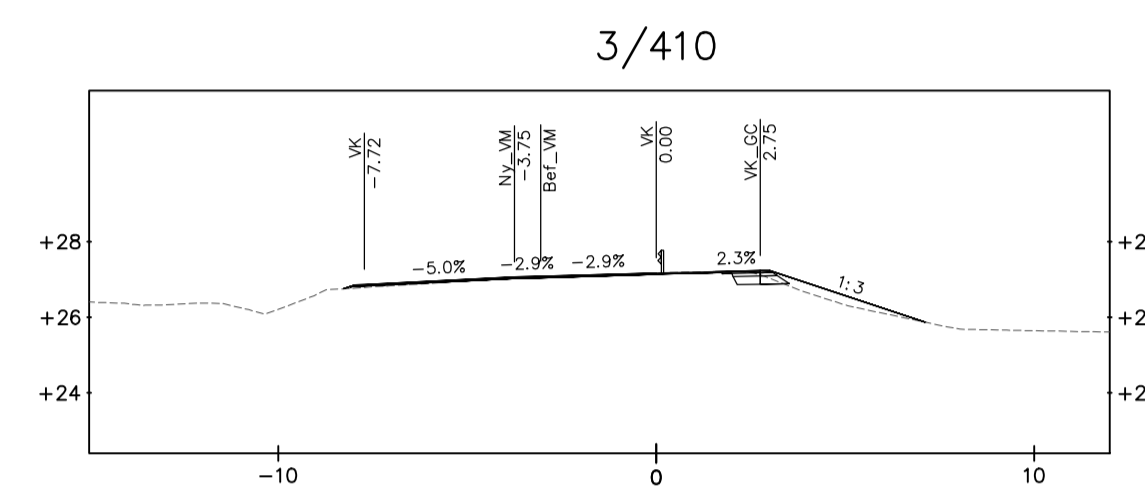
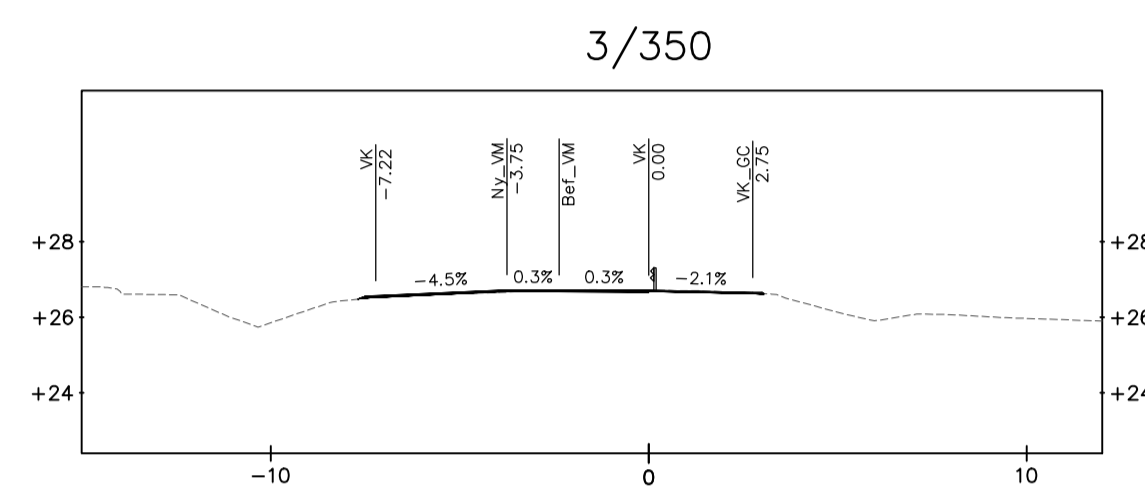
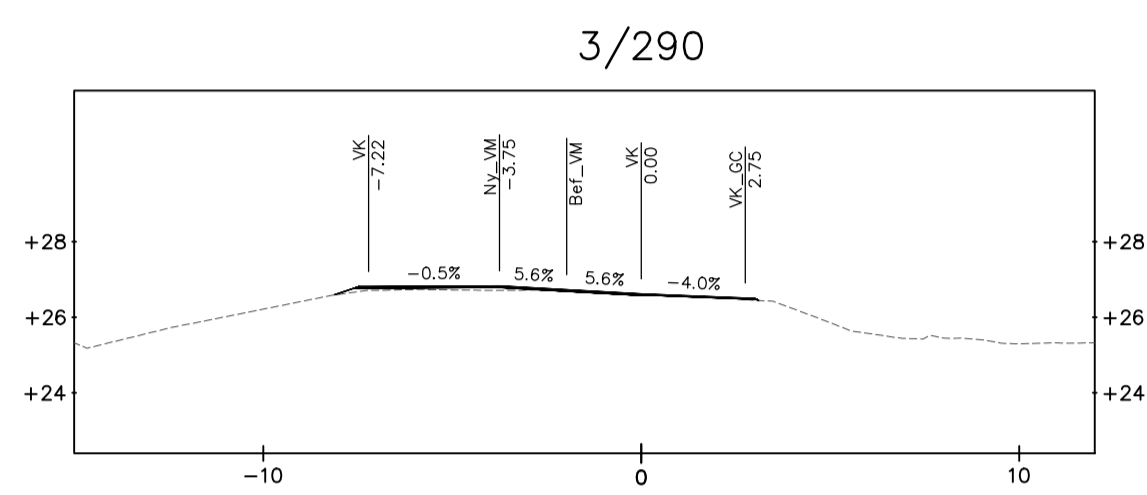
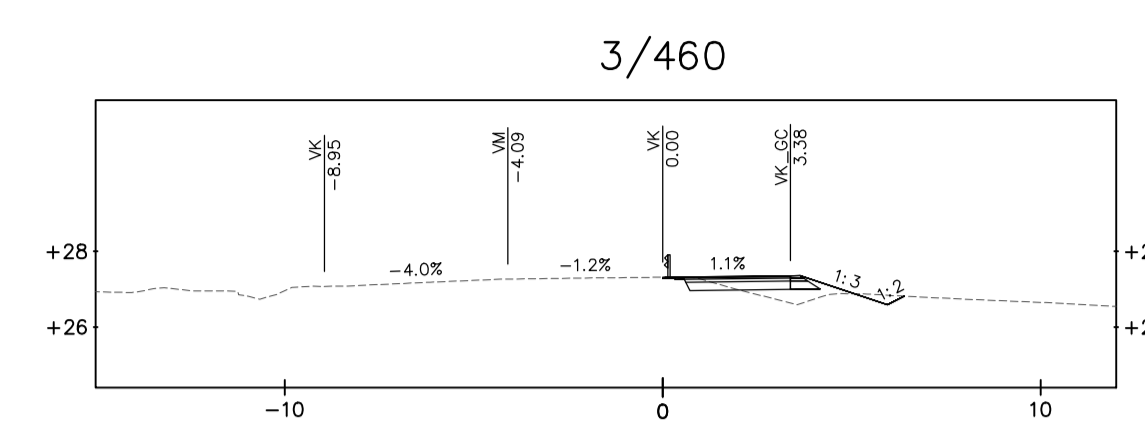
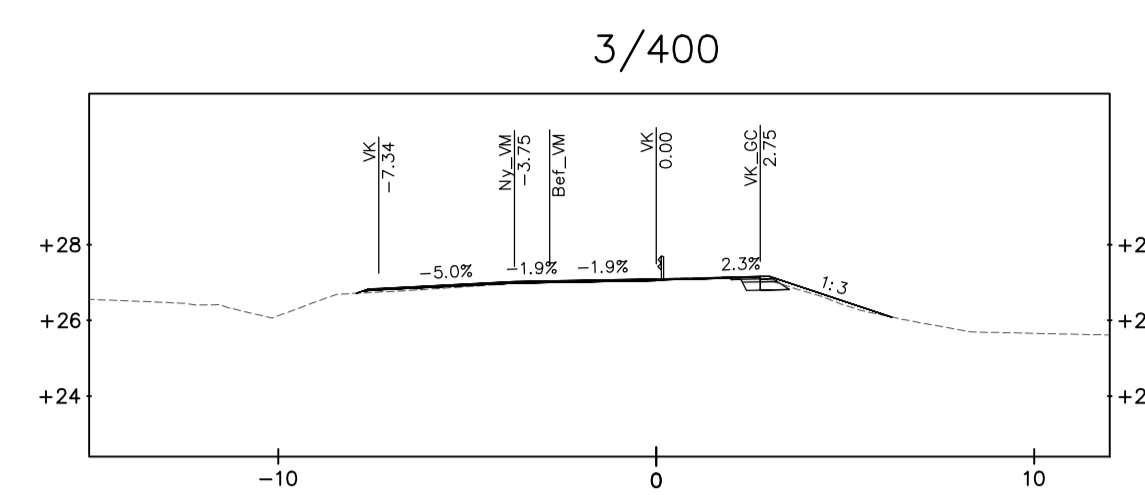
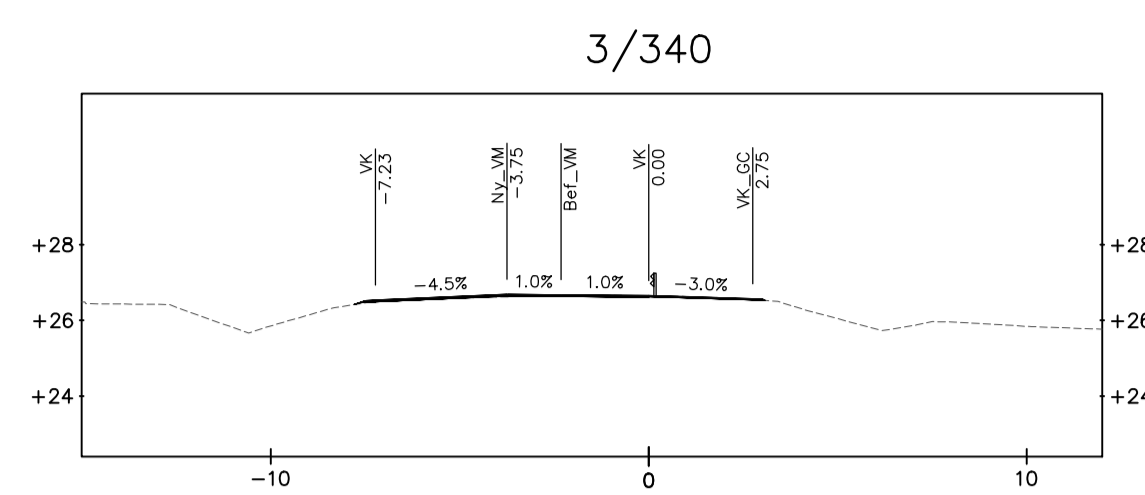
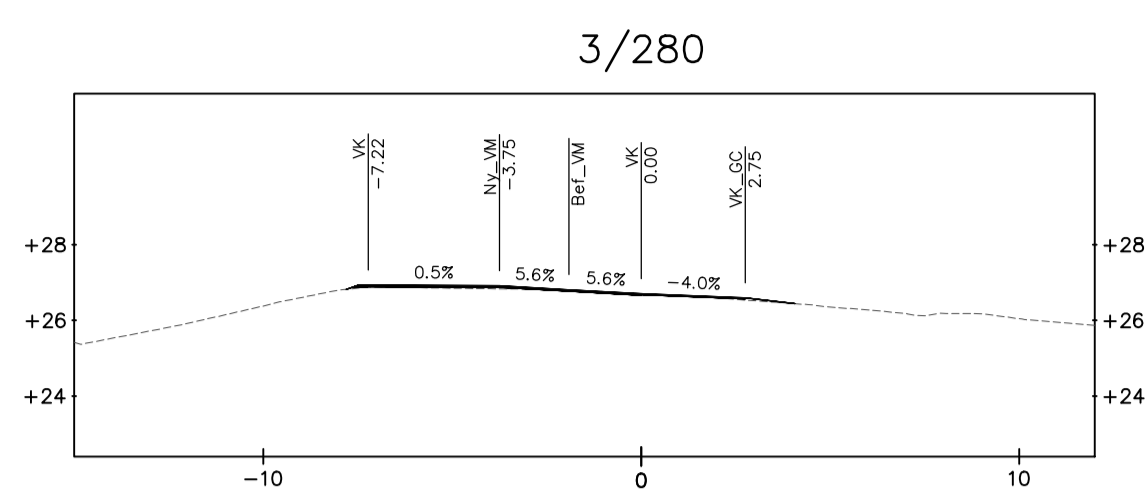

# KOORDINATSYSTEM

PLAN: SWEREF 99 18 00  
HÖJD: RH 2000

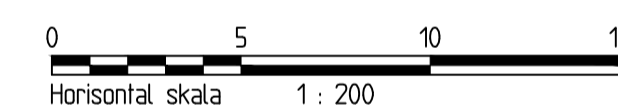

TYP AV PLAN		<b>VÄGPLAN</b>	
GRANSKNINGSSTATUS / SYFTE			
HANDLINGSTYP			
<b>GRANSKNINGSHANDLING</b>			
DATUM		LEVERANS / ÄNDRINGS-PM	
2024-04-04			
OBJEKT			
<b>GC-VÄG</b>			
<b>TIERP - TIERPS KYRKBY</b>			
DELOMRÅDE / BANDEL			
TIERP			
ANLÄGGNINGSGDEL			
TIERP - TIERPS KYRKBY			
OBJEKTNUMMER / KM	KONSTRUKTIONSNUMMER		
169470			
BESTÄLLARE	LEVERANTÖR		
<b>TRAFIKVERKET</b>	<b>SYSTRA</b>		
SKAPAD AV	UPPDRAGSGNUMMER		
<b>M. VALL</b>	2013741		
GODKÄND AV	ÄVDELNING		
<b>J. NILSSON</b>			
RITNINGSTYP			
<b>SEKTIONS-RITNING</b>			
TEKNIKOMRÅDE / INNEHÅLL			
<b>VÄGUTFORMNING OCH TRAFIK</b>			
BESKRIVNING			
<b>TVÄRSEKTIONER LINJE 202-GC</b>			
3/280 - 3/470			
SKALA	FORMAT	FÖRVALTNINGSNUMMER	
1:200	A1		
RITNINGSNUMMER	BLAD	NÄSTA BLAD	BET
2 02 T 09 15			